

Model J-P4
(Machine Code: G130/G131)

SERVICE MANUAL

22 April 2005
Subject to change

TABLE OF CONTENTS

1. INSTALLATION	1-1
1.1 INSTALLATION REQUIREMENTS	1-1
1.1.1 ENVIRONMENT	1-1
1.1.2 MACHINE LEVEL	1-1
1.1.3 MACHINE SPACE REQUIREMENT	1-2
Printer	1-2
Printer and Finisher.....	1-2
1.1.4 POWER REQUIREMENTS	1-3
1.2 OPTIONAL UNIT COMBINATIONS	1-4
1.3 PRINTER.....	1-5
1.3.1 POWER SOCKETS FOR PERIPHERALS	1-5
1.3.2 INSTALLATION FLOW CHART.....	1-6
1.3.3 INSTALLATION AND SETTINGS.....	1-7
1.3.4 MOVING THE MACHINE	1-8
1.3.5 TRANSPORTING THE MACHINE.....	1-9
After a Machine Test.....	1-9
Transporting a Used Machine.....	1-9
Necessary Adjustment after Transportation.....	1-9
Preparing the Printer.....	1-10
1.4 OPTIONAL UNIT	1-12
1.4.1 TWO-TRAY FINISHER.....	1-12
Accessory Check	1-12
Installation Procedure	1-12
1.4.2 PUNCH UNIT	1-18
Accessory Check	1-18
Installation Procedure	1-19
1.4.3 BOOKLET FINISHER.....	1-22
Accessory Check	1-22
Adjusting the Height.....	1-23
Main Body.....	1-24
1.4.4 OPTIONAL PUNCH UNIT	1-27
Accessory Check	1-27
Installation Procedure	1-27
2. PREVENTIVE MAINTENANCE.....	2-1
2.1 USER MAINTENANCE	2-1
Maintenance Kit	2-1
PM Alert Display	2-1
New Unit Detection	2-1
PM Table	2-2
2.2 SERVICE MAINTENANCE.....	2-3
PM Counter Reset	2-3
PM Table	2-3

3. REPLACEMENT AND ADJUSTMENT.....	3-1
3.1 SPECIAL TOOLS	3-1
3.2 IMAGE ADJUSTMENT	3-2
3.2.1 REGISTRATION.....	3-2
Image Area	3-2
Leading Edge.....	3-2
Side to Side	3-2
Adjustment Standard	3-2
Paper Registration Standard.....	3-2
Adjustment Procedure	3-3
3.2.2 COLOR REGISTRATION	3-3
Line Position Adjustment	3-3
Adjustment of Line Speed for Thick Paper.....	3-3
3.2.3 PRINTER GAMMA	3-4
Adjustment Overview.....	3-4
Adjustment Procedure	3-4
3.3 DUPLEX INVERTER UNIT	3-5
3.3.1 TOP COVER	3-5
3.3.2 DUPLEX INVERTER MOTOR 1 AND CONTROL BOARD	3-5
3.3.3 DUPLEX INVERTER MOTOR 2 AND SWITCH	3-7
3.3.4 EXIT SENSOR 3 AND DUPLEX INVERTER SENSOR.....	3-7
3.3.5 EXIT SENSOR 1 AND 2	3-7
3.4 DUPLEX FEED UNIT	3-8
3.4.1 DUPLEX DRIVE BOARD.....	3-8
3.4.2 DUPLEX FEED MOTOR	3-8
3.4.3 DUPLEX FEED SENSOR.....	3-9
3.5 EXTERIOR COVERS	3-10
3.5.1 REAR COVER AND UPPER REAR COVER	3-10
3.5.2 PAPER EXIT TRAY	3-10
3.5.3 UPPER RIGHT COVER	3-11
3.5.4 FRONT COVER.....	3-11
3.5.5 LEFT SIDE	3-12
3.5.6 UPPER LEFT COVER AND OPERATION PANEL.....	3-13
3.6 LASER OPTICS	3-14
3.6.1 CAUTION DECAL LOCATIONS.....	3-14
3.6.2 LASER OPTICS HOUSING UNIT.....	3-15
Adjustments after Replacing the Laser Optics Housing Unit.....	3-20
3.6.3 POLYGON MIRROR MOTOR	3-21
3.6.4 POLYGON MIRROR MOTOR DRIVE BOARD	3-22
3.6.5 LASER SYNCHRONIZING DETECTOR BOARDS	3-22
3.7 PCU AND DEVELOPMENT UNIT	3-23
3.8 PAPER FEED.....	3-24
3.8.1 PICK-UP, FEED, AND SEPARATION ROLLERS	3-24
Tray 1 and Tray 2.....	3-24
By-pass Tray.....	3-24
3.8.2 PAPER WIDTH DETECTION BOARD	3-25
3.8.3 VERTICAL TRANSPORT SENSOR.....	3-26
3.8.4 RIGHT DOOR UNIT	3-26
3.8.5 REGISTRATION SENSOR AND RELAY SENSORS.....	3-27

3.8.6	PAPER FEED CLUTCHES.....	3-27
3.8.7	BY-PASS FEED CLUTCH.....	3-28
3.8.8	TRAY LIFT MOTOR.....	3-28
3.8.9	PAPER FEED MOTOR.....	3-29
3.9	TRANSFER AND PAPER TRANSPORT UNIT.....	3-30
3.9.1	TRANSFER UNIT.....	3-30
3.9.2	TRANSFER BELT CLEANING UNIT.....	3-31
3.9.3	CLEANING BLADE AND CLEANING ROLLER.....	3-32
3.9.4	TRANSFER BELT.....	3-34
	When you reinstall the transfer belt.....	3-35
3.9.5	TRANSFER UNIT DRIVE MOTOR.....	3-36
3.10	ID SENSORS.....	3-37
3.11	FUSING.....	3-38
3.11.1	FUSING UNIT.....	3-38
3.11.2	UPPER COVER.....	3-39
3.11.3	THERMOSTAT AND HEATING ROLLER THERMISTOR.....	3-40
3.11.4	PRESSURE ROLLER THERMISTOR AND FUSE.....	3-41
	Reassembling.....	3-41
3.11.5	HEATING ROLLER LAMP AND PRESSURE ROLLER LAMP.....	3-42
3.11.6	FUSING BELT UNIT.....	3-43
3.11.7	HOT ROLLER AND HEATING ROLLER.....	3-44
	Reassembling.....	3-44
3.11.8	UPPER PAPER GUIDE PLATE AND STRIPPER PAWLS.....	3-45
3.11.9	LOWER PAPER GUIDE PLATE AND STRIPPER PAWLS.....	3-46
3.11.10	CLEANING ROLLER AND OIL SUPPLY ROLLER.....	3-47
3.11.11	PRESSURE ROLLER.....	3-48
	Reassembling.....	3-48
3.11.12	DRIVE GEAR.....	3-48
3.11.13	FUSING UNIT FAN.....	3-49
3.11.14	PAPER EXIT.....	3-50
3.12	ELECTRICAL COMPONENTS.....	3-51
3.12.1	MOVING THE CONTROLLER BOX OUT OF THE WAY.....	3-51
3.12.2	MOVING THE HIGH VOLTAGE SUPPLY UNIT - C, B OUT OF THE WAY.....	3-52
3.12.3	CONTROLLER, IPU, AND BCU.....	3-52
3.12.4	HDD.....	3-54
3.12.5	NVRAM REPLACEMENT PROCEDURE.....	3-55
	NVRAM on the BCU.....	3-55
	NVRAM on the Controller.....	3-56
3.12.6	REMOVING THE HIGH VOLTAGE SUPPLY BOARD - C, B.....	3-57
3.12.7	SUB POWER SUPPLY UNIT.....	3-57
3.12.8	PSU.....	3-58
3.12.9	CIRCUIT BREAKER AND PSU FAN.....	3-58
3.12.10	CHOKE COIL.....	3-59
3.12.11	DRIVER BOARD.....	3-59
3.13	DRIVE UNIT.....	3-60
3.13.1	REGISTRATION CLUTCH.....	3-60
3.13.2	DEVELOPMENT CLUTCHES.....	3-60
3.13.3	DEVELOPMENT MOTOR - CMY.....	3-61

3.13.4	DRUM DRIVE MOTOR - CMY AND DRUM DRIVE MOTOR - K.....	3-63
3.13.5	DEVELOPMENT DRIVE MOTOR - K.....	3-64
3.14	TONER SUPPLY UNIT	3-65
M	Toner Supply Unit	3-65
C and Y	Toner Supply Units	3-69
K	Toner Supply Unit.....	3-70
4.	TROUBLESHOOTING	4-1
4.1	PROCESS CONTROL ERROR CONDITIONS	4-1
4.1.1	DEVELOPER INITIALIZATION RESULT	4-1
4.1.2	PROCESS CONTROL SELF-CHECK RESULT	4-3
4.1.3	LINE POSITION ADJUSTMENT RESULT	4-4
4.2	SERVICE CALL CONDITIONS	4-8
4.2.1	SUMMARY	4-8
SC	Code Classification	4-9
4.3	SC TABLE	4-10
4.4	TROUBLESHOOTING GUIDE 1	4-43
4.4.1	IMAGE QUALITY.....	4-43
Work-flow	4-43
4.5	TROUBLESHOOTING GUIDE 2	4-45
4.5.1	IMAGE QUALITY.....	4-45
Detailed	Explanation.....	4-49
4.5.2	COLOR SHIFT.....	4-54
Adjustment	Standard: Max. 150 mm.....	4-56
How to	measure the gap between color lines	4-62
4.5.3	COLOR SHIFT AFTER TRANSFER UNIT REPLACEMENT	4-64
Check the	color shift level	4-64
Fusing/	Registration Roller Speed Adjustment	4-64
4.5.4	BLACK OVER PRINT	4-67
Black	Over Print Disabled	4-67
Black	Over Print Enabled.....	4-67
4.6	ELECTRICAL COMPONENT DEFECTS	4-68
4.7.1	SENSORS	4-68
4.7	BLOWN FUSE CONDITIONS	4-70
4.8	LEDS (BCU).....	4-70
5.	SERVICE TABLES.....	5-1
5.1	SERVICE PROGRAM MODE.....	5-1
5.1.1	HANDLING SERVICE PROGRAM MODE	5-1
Starting	SP Mode.....	5-1
Selecting	a Service Program	5-2
Changing	a Setting	5-2
Quitting	SP Mode.....	5-2
Enabling	Settings.....	5-2
Line	Position Adjustment	5-2
5.1.2	REMARKS.....	5-3
Abbreviations	and Symbols	5-3
Possible	Values	5-3
Process	Speed	5-4

5.2	CONTROLLER SERVICE MODE.....	5-5
5.2.1	SERVICE MODE TABLE.....	5-5
5.2.2	BIT SWITCH PROGRAMMING.....	5-7
5.3	ENGINE SERVICE MODE.....	5-8
5.3.1	SERVICE MODE TABLE.....	5-8
	SP1-XXX (Feed).....	5-8
	SP2-XXX (Drum).....	5-19
	SP3-XXX (Process).....	5-37
	SP5-XXX (Mode).....	5-46
	SP6-XXX (Peripherals).....	5-68
	SP7-XXX (Data Log).....	5-69
	SP8-XXX (Data Log 2).....	5-77
5.3.2	MEMORY CLEAR/COUNTER CLEAR.....	5-87
5.3.3	INPUT CHECK TABLE.....	5-88
	Table 1: Paper Height Sensor.....	5-90
	Table 2: Paper Size Switch (Tray 2).....	5-90
	Table 3: Paper Size (By-pass Table).....	5-91
5.3.4	OUTPUT CHECK TABLE.....	5-92
5.3.5	TEST PATTERN (SP5-997).....	5-97
5.4	FIRMWARE UPDATE.....	5-98
5.4.1	TYPE OF FIRMWARE.....	5-98
5.4.2	PRECAUTIONS.....	5-98
	Handling SD Cards.....	5-98
	Upload or Download.....	5-98
	Network Connection.....	5-98
5.4.3	FILE ARRANGEMENT.....	5-99
	How the Program Works.....	5-99
	Example.....	5-99
5.4.4	UPDATING.....	5-100
	Procedure.....	5-100
	Error Handling.....	5-101
	Power Failure.....	5-101
5.4.5	NVRAM DATA UPLOAD/DOWNLOAD.....	5-102
	Uploading NVRAM Data.....	5-102
	Downloading NVRAM Data.....	5-103
5.4.6	ERROR CODE TABLE.....	5-104
5.5	SD CARD APPLI MOVE.....	5-105
5.5.1	OVERVIEW.....	5-105
5.5.2	MOVE EXEC.....	5-106
5.5.3	UNDO EXEC.....	5-107
5.6	CONTROLLER SELF-DIAGNOSTICS.....	5-108
5.6.1	OVERVIEW.....	5-108
5.6.2	DETAILED SELF-DIAGNOSTICS.....	5-109
5.7	USER PROGRAM MODE.....	5-110
	Starting a User Program.....	5-110
	Quitting a User Program.....	5-110
	Menu List.....	5-110
5.8	DIP SWITCHES.....	5-111
	Controller Board.....	5-111

BCU Board.....	5-111
----------------	-------

6. DETAILED SECTION DESCRIPTIONS	6-1
6.1 OVERVIEW	6-1
6.1.1 COMPONENT LAYOUT	6-1
6.1.2 PAPER PATH.....	6-2
6.1.3 DRIVE LAYOUT	6-3
6.1.4 BOARD STRUCTURE.....	6-4
Overview.....	6-4
6.1.5 PRINTING PROCESS	6-6
6.2 PROCESS CONTROL	6-8
6.2.1 OVERVIEW	6-8
6.2.2 POTENTIAL CONTROL	6-8
Overview.....	6-8
Process Control Self Check.....	6-9
6.2.3 PROCESS CONTROL SELF CHECK PROCEDURE	6-10
Step 1: VSG Adjustment.....	6-10
Step 2: ID Sensor Solid Pattern Generation	6-11
Step 3: Sensor Pattern Detection	6-11
Step 4: Toner Amount Calculation	6-11
Step 5: VD, VB, VL Selection and VREF Adjustment	6-12
Step 6: ID Sensor Highlight Pattern Generation	6-13
Step 7: Sensor Pattern Density Detection.....	6-13
Step 8: VL (LD Power) Selection	6-13
6.2.4 VREF COMPENSATION DURING A PRINT JOB.....	6-14
Highlight Pattern	6-14
Adjustment Process.....	6-14
6.2.5 TONER SUPPLY CONTROL	6-15
Overview.....	6-15
Toner Supply Control Modes.....	6-15
6.2.6 TONER NEAR END/TONER END DETECTION.....	6-16
Introduction.....	6-16
Toner Near End Detection 1	6-17
Toner Near End Detection 2	6-17
Toner End Detection.....	6-18
Toner End Recovery.....	6-18
6.2.7 DEVELOPER INITIALIZATION	6-19
6.3 LASER EXPOSURE	6-20
6.3.1 OVERVIEW	6-20
6.3.2 OPTICAL PATH.....	6-21
6.3.3 LASER SYNCHRONIZING DETECTOR	6-22
Overview.....	6-22
Main Scan Start Detection	6-22
Clock Frequency Adjustment.....	6-22
6.3.4 LD SAFETY SWITCH.....	6-23
Front and Upper Left Cover Switch.....	6-23
Error Messages	6-24
6.3.5 AUTOMATIC LINE POSITION ADJUSTMENT.....	6-25
Overview.....	6-25

Summary of Each Adjustment	6-26
Adjustment Conditions	6-27
Main Scan Skew Adjustment	6-28
6.4 PHOTOCONDUCTOR UNIT	6-29
6.4.1 OVERVIEW	6-29
6.4.2 DRIVE.....	6-30
6.4.3 DRUM GEAR POSITION SENSORS	6-31
Mechanism	6-31
Initialization Process and SC Codes	6-32
6.4.4 DRUM CHARGE AND QUENCHING	6-33
6.4.5 DRUM CLEANING.....	6-34
6.4.6 WASTE TONER COLLECTION.....	6-35
Waste Toner Path	6-35
6.4.7 WASTE TONER BOTTLE FULL DETECTION	6-37
6.5 DEVELOPMENT	6-38
6.5.1 OVERVIEW	6-38
6.5.2 DRIVE.....	6-39
6.5.3 DEVELOPER AGITATION	6-40
6.5.4 DEVELOPMENT BIAS	6-41
6.5.5 TONER SUPPLY MECHANISM	6-42
Overview	6-42
Toner Agitation and Attraction	6-42
Air Flow and Toner Flow	6-43
Toner Near End Detection	6-43
Toner Transport	6-44
6.5.6 TONER CARTRIDGE DETECTION	6-45
6.6 PAPER FEED.....	6-46
6.6.1 OVERVIEW	6-46
6.6.2 DRIVE – TRAY 1, TRAY 2, AND BY-PASS TRAY	6-47
6.6.3 PAPER LIFT – TRAYS 1 & 2.....	6-48
6.6.4 PAPER SIZE DETECTION – TRAYS 1 & 2.....	6-49
6.6.5 PAPER HEIGHT DETECTION – TRAYS 1 & 2.....	6-50
6.6.6 PAPER END DETECTION – TRAYS 1 & 2	6-50
6.6.7 REGISTRATION.....	6-51
6.6.8 PAPER FEED LINE SPEED.....	6-52
6.6.9 GRIP ROLLER RELEASE MECHANISM	6-53
6.7 IMAGE TRANSFER AND PAPER SEPARATION	6-54
6.7.1 OVERVIEW	6-54
6.7.2 TRANSFER BELT DRIVE	6-55
Drive Motor	6-55
Transfer belt speed control	6-56
Transfer belt mark sensor	6-57
6.7.3 TRANSFER CURRENT	6-58
6.7.4 TRANSFER BELT CLEANING	6-59
6.7.5 TRANSFER BELT CONTACT	6-60
Mechanism	6-60
Transfer Belt Sensor	6-61
6.7.6 ACS (AUTO COLOR SENSING) MODE	6-62
6.8 FUSING.....	6-63

6.8.1	OVERVIEW	6-63
6.8.2	FUSING UNIT DRIVE.....	6-64
	Belt and Rollers	6-64
	Fusing Clutch.....	6-64
6.8.3	FUSING TEMPERATURE CONTROL.....	6-65
	Fusing Temperatures.....	6-65
	Temperature Corrections	6-66
	Overheat Protection	6-66
6.8.4	NEW FUSING UNIT DETECTION.....	6-67
6.8.5	ENERGY SAVER MODES	6-68
	Level 1 Energy Saver Mode.....	6-68
	Level 2 Energy Saver Mode.....	6-68
6.9	PAPER EXIT	6-69
6.9.1	OVERVIEW	6-69
6.9.2	PAPER OVERFLOW DETECTION	6-70
6.10	DUPLEX UNIT	6-71
6.10.1	OVERVIEW	6-71
6.10.2	DUPLEX OPERATION	6-72
	Up to A4/LT (8 1/2" x 11") LEF	6-72
	Larger than A4/LT (8 1/2" x 11") LEF.....	6-72
6.10.3	DUPLEX INVERTER UNIT	6-73
6.10.4	FEED TO EXTERNAL EXIT TRAY (NON-DUPLEX MODE)	6-74
6.10.5	FEED TO DUPLEX FEED UNIT	6-75
6.10.6	FEED TO TWO-TRAY FINISHER AND BOOKLET FINISHER	6-76
	With Optional One-Tray Paper Feed Unit	6-76
	With Optional LCT or Two-Tray Paper Feed Unit	6-76
6.10.7	DUPLEX FEED UNIT	6-77
	Drive	6-77
	Feed-in and feed-out.....	6-77
6.11	PRINTER FUNCTIONS.....	6-78
6.11.1	OVERVIEW	6-78
6.11.2	HARD DISK	6-79
	Overview	6-79
6.11.3	PRINT DATA PROCESSING	6-80
	RPCS Driver	6-80
	PCL5e/PCL6c Driver.....	6-80
	PS3 Driver	6-81
	CMS (Color Management System).....	6-81
	Gray Correction	6-81
	BG/UCR (Black Generation/Under Color Removal).....	6-81
	Gamma Correction.....	6-81
	Toner Limitation	6-82
	Dither Processing and ROP/RIP	6-82
6.11.4	CONTROLLER FUNCTIONS	6-83
	Sample Print	6-83
	Hold Print.....	6-83
	Locked Print.....	6-83
	Stored Print.....	6-83
6.11.5	JOB SPOOLING.....	6-84

Related SP Modes	6-84
Paper Source Selection	6-85
Auto Continue	6-86
Paper Output Tray	6-87
Stapling	6-87
Punching	6-88
6.12 PICTBRIDGE	6-89

SPECIFICATIONS	SPEC-1
1. GENERAL SPECIFICATIONS	SPEC-1
2. SUPPORTED PAPER SIZES	SPEC-4
2.1 PAPER FEED	SPEC-4
2.2 PAPER EXIT	SPEC-5
3. SOFTWARE ACCESSORIES	SPEC-6
3.1 PRINTER DRIVERS	SPEC-6
3.2 UTILITY SOFTWARE	SPEC-6
4. MACHINE CONFIGURATION	SPEC-7
Controller	SPEC-8
Others	SPEC-8
5. OPTIONAL EQUIPMENT	SPEC-9
5.1 500-SHEET TRAY	SPEC-9
5.2 1000-SHEET TRAY	SPEC-9
5.3 2000-SHEET LARGE CAPACITY TRAY	SPEC-9
5.4 TWO-TRAY FINISHER & PUNCH UNIT	SPEC-10
5.5 BOOKLET FINISHER	SPEC-11

IMPORTANT SAFETY NOTICES

PREVENTION OF PHYSICAL INJURY

1. Before disassembling or assembling parts of the printer and peripherals, make sure that the printer power cord is unplugged.
2. The wall outlet should be near the printer and easily accessible.
3. If any adjustment or operation check has to be made with exterior covers off or open while the main switch is turned on, keep hands away from electrified or mechanically driven components.
4. The printer drives some of its components when it completes the warm-up period. Be careful to keep hands away from the mechanical and electrical components as the printer starts operation.
5. The inside and the metal parts of the fusing unit become extremely hot while the printer is operating. Be careful to avoid touching those components with your bare hands.

HEALTH SAFETY CONDITIONS

Toner and developer are non-toxic, but if you get either of them in your eyes by accident, it may cause temporary eye discomfort. Immediately wash eyes with plenty of water. If unsuccessful, get medical attention.

OBSERVANCE OF ELECTRICAL SAFETY STANDARDS

The printer and its peripherals must be serviced by a customer service representative who has completed the training course on those models.

CAUTION

1. Always replace a lithium battery on the controller with the same type of battery prescribed for use on that board. Replacing a lithium battery with any type other than the one prescribed for use on the controller could lead to an explosion or damage to the controller.
2. Never discard used batteries by mixing them with other trash. Remove them from the work site and dispose of them in accordance with local laws and regulations regarding the disposal of such items.

SAFETY AND ECOLOGICAL NOTES FOR DISPOSAL

1. Do not incinerate toner bottles or used toner. Toner dust may ignite suddenly when exposed to an open flame.
2. Dispose of used toner, the maintenance unit which includes developer or the organic photoconductor in accordance with local regulations. (These are non-toxic supplies.)
3. Dispose of replaced parts in accordance with local regulations.
4. When keeping used lithium batteries in order to dispose of them later, do not put more than 100 batteries per sealed box. Storing larger numbers or not sealing them apart may lead to chemical reactions and heat build-up.

LASER SAFETY

The Center for Devices and Radiological Health (CDRH) prohibits the repair of laser-based optical units in the field. The optical housing unit can only be repaired in a factory or at a location with the requisite equipment. The laser subsystem is replaceable in the field by a qualified Customer Engineer. The laser chassis is not repairable in the field. Customer engineers are therefore directed to return all chassis and laser subsystems to the factory or service depot when replacement of the optical subsystem is required.

WARNING

Use of controls, or adjustment, or performance of procedures other than those specified in this manual may result in hazardous radiation exposure.

WARNING

WARNING: Turn off the main switch before attempting any of the procedures in the Laser Optics Housing Unit section. Laser beams can seriously damage your eyes.

CAUTION MARKING:

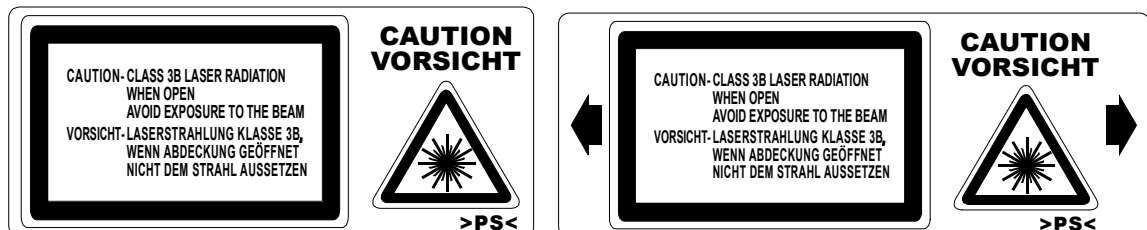

Trademarks

Microsoft®, Windows®, and MS-DOS® are registered trademarks of Microsoft Corporation in the United States and /or other countries.

PostScript® is a registered trademark of Adobe Systems, Incorporated.

PCL® is a registered trademark of Hewlett-Packard Company.





Ethernet® is a registered trademark of Xerox Corporation.

PowerPC® is a registered trademark of International Business Machines Corporation.

Other product names used herein are for identification purposes only and may be trademarks of their respective companies. We disclaim any and all rights involved with those marks.

Symbols and Abbreviations

This manual uses the symbols and abbreviations shown below.

Symbol	Meaning
	Refer to section number
	Clip ring
	Screw
	Connector
SEF	Short Edge Feed
LEF	Long Edge Feed

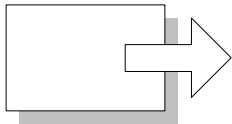

Short Edge Feed (SEF)

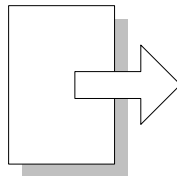

Long Edge Feed (LEF)

1. INSTALLATION

1.1 INSTALLATION REQUIREMENT

1.1.1 ENVIRONMENT

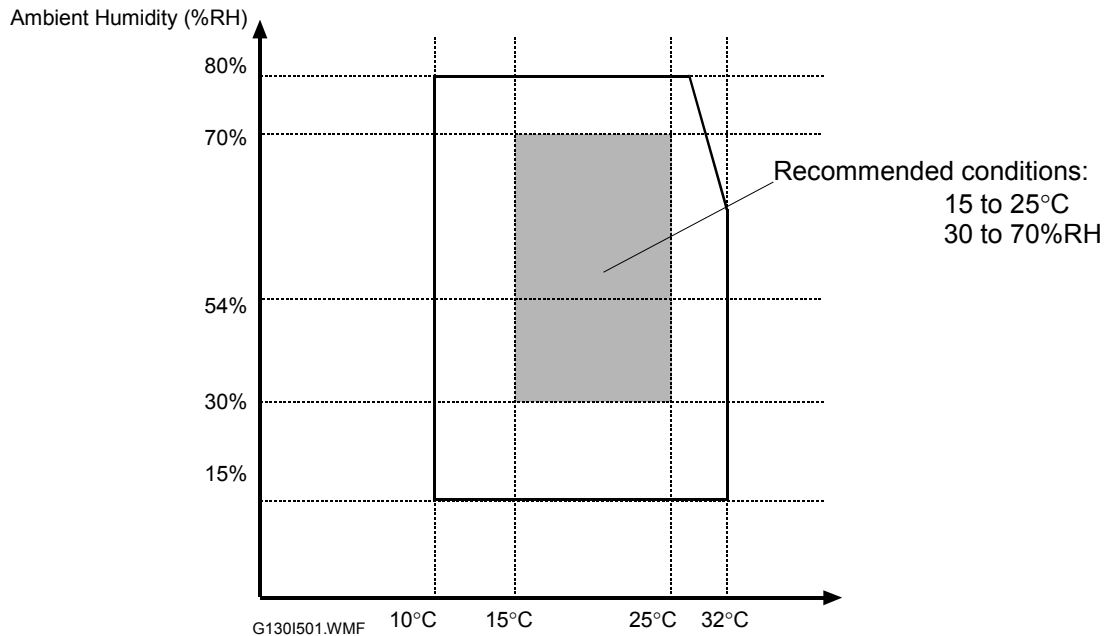

1. Temperature Range: 10°C to 32°C (50°F to 89.6°F)
2. Humidity Range: 15% to 80% RH
3. Ambient Illumination: Less than 2,000 lux (do not expose to direct sunlight)
4. Ventilation: 3 times/hour/person or more
5. Do not expose the machine to the following:
 - 1) Direct cool air from an air conditioner
 - 2) Direct heat from a heater
6. Do not install the machine in areas that get exposed to corrosive gas.
7. Install the machine locations lower than 2,500 m (8,200 ft.) above sea level.
8. Install the machine on a strong, level base (☛ 1.1.2).
9. Do not install the machine in areas that get strong vibrations.

1.1.2 MACHINE LEVEL

Front to back: Within 5 mm (0.2")

Right to left: Within 5 mm (0.2")

1.1.3 MACHINE SPACE REQUIREMENT

Install the machine near the power source. The diagrams show the necessary space.

Printer

P4a: G130

P4c: G131 (Duplex unit and HDD unit are installed as standard units.)

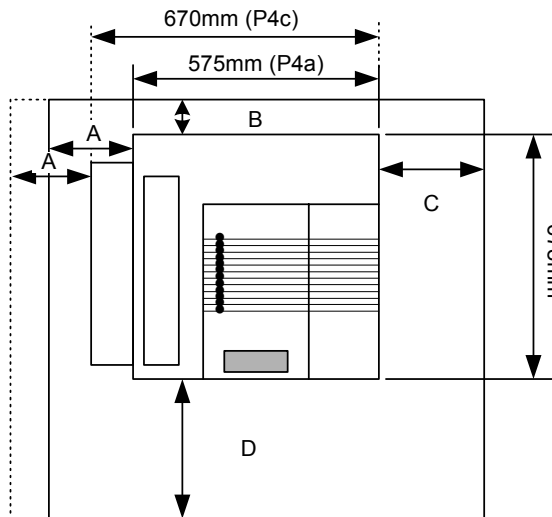

- A: Over 460 mm (18")
- B: Over 100 mm (4")
- C: Over 550 mm (22")
- D: Over 700 mm (28")

G130I502.WMF

Printer and Finisher

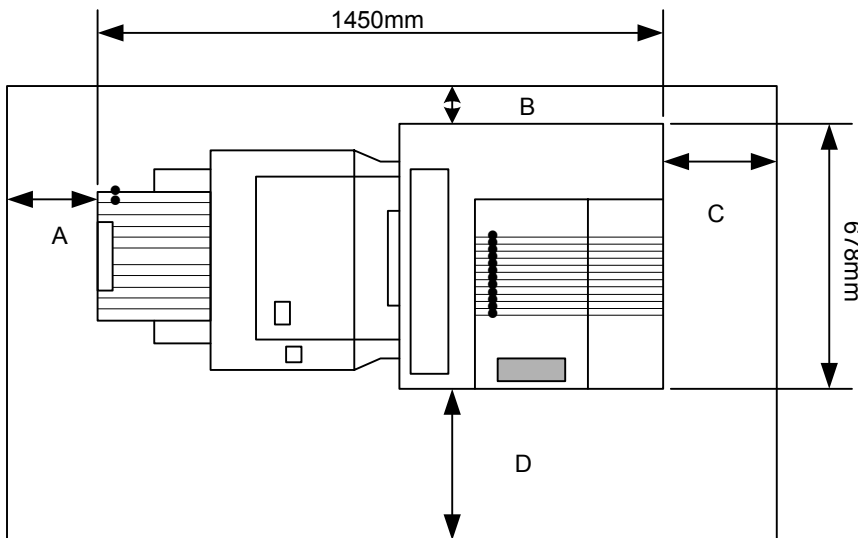

G130I503.WMF

- [A]: Over 460 mm (18")
- [B]: Over 100 mm (4")
- [C]: Over 550 mm (22")
- [D]: Over 700 mm (28")

1.1.4 POWER REQUIREMENTS

⚠ CAUTION

1. Insert the plug firmly in the outlet.
2. Do not use an outlet extension plug or cord.
3. Ground the machine.

1. Input voltage level:

NA: 120 V, 60 Hz: More than 12 A (G131)/ 11 A (G130)

EU/ASIA: 220 V ~ 240 V, 50 Hz/60 Hz: More than 7 A (G131)/ 6 A (G130)

2. Permissible voltage fluctuation: $\pm 10\%$
3. Do not put or place anything on the power cord.

1.2 OPTIONAL UNIT COMBINATIONS

No.	Options	Remarks
1	One-tray paper feed unit	You can only install one of these three
2	Two-tray paper feed unit	
3	Large capacity tray	
4	Two-tray finisher	One from No. 4 and No. 6; No. 8 necessary
5	Punch kit (3 types)	No. 4 necessary; One of the three types
6	Booklet Finisher	One from No. 4 and No. 6; No. 8 necessary
7	Punch unit (4 types)	No. 6 necessary; One of the four types
8	Duplex unit	Standard for G131
9	64 MB memory	You can only install one of these three
10	128 MB memory	
11	256 MB memory	
12	40 GB HDD unit	Standard for G131
13	IEEE 1284	You can only install one of these six
14	IEEE 1394	
15	IEEE 802.11b	
16	Bluetooth	
17	Gigabit Ethernet	
18	USB Host I/F	
19	PictBridge	No.18 necessary
20	NVRAM memory	

1.3 PRINTER

1.3.1 POWER SOCKETS FOR PERIPHERALS

⚠ CAUTION

Rating voltage for peripherals.

Make sure to plug the cables into the correct sockets.

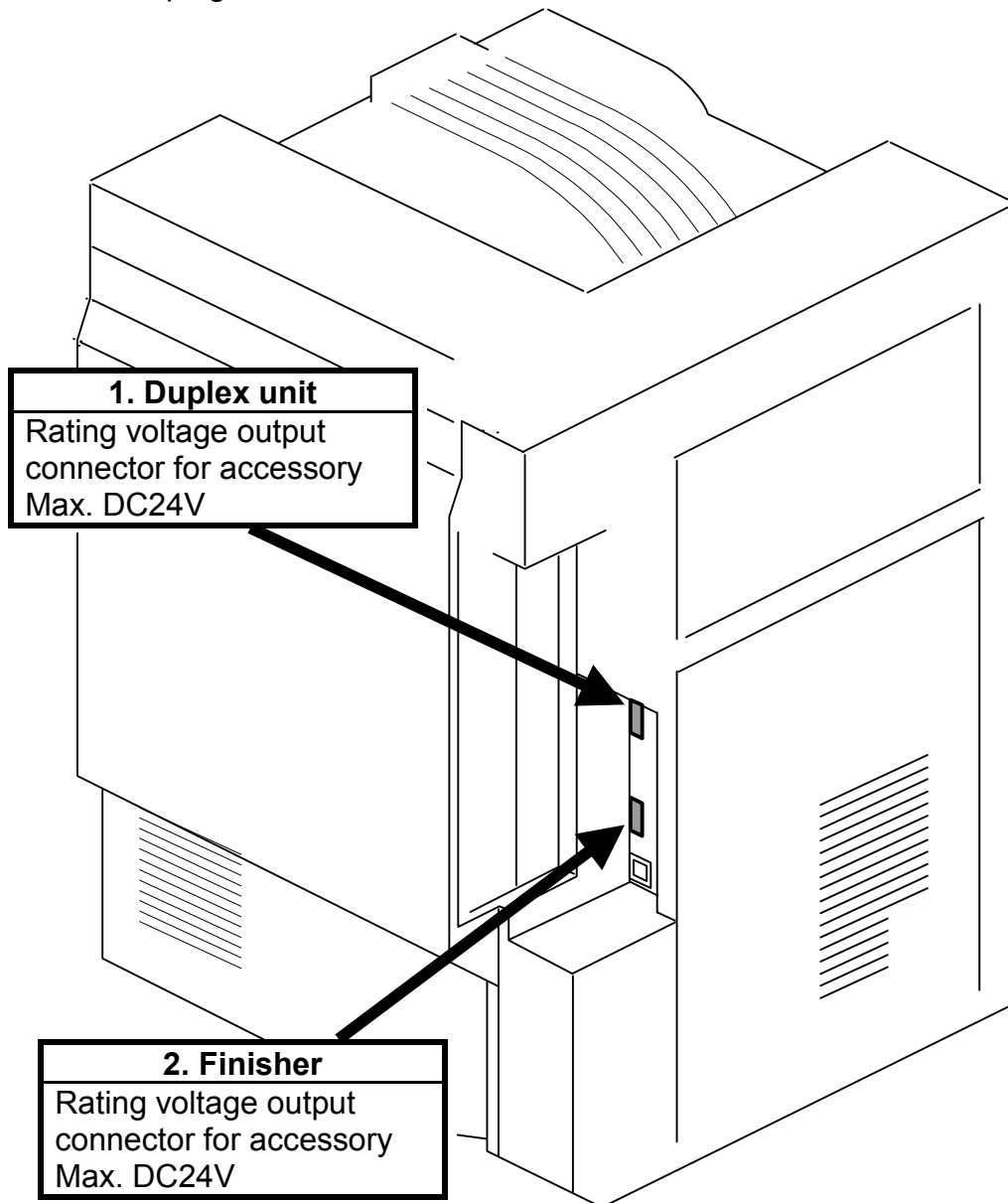

G1301504.WMF

1.3.2 INSTALLATION FLOW CHART

The flow chart shows the installation procedure.

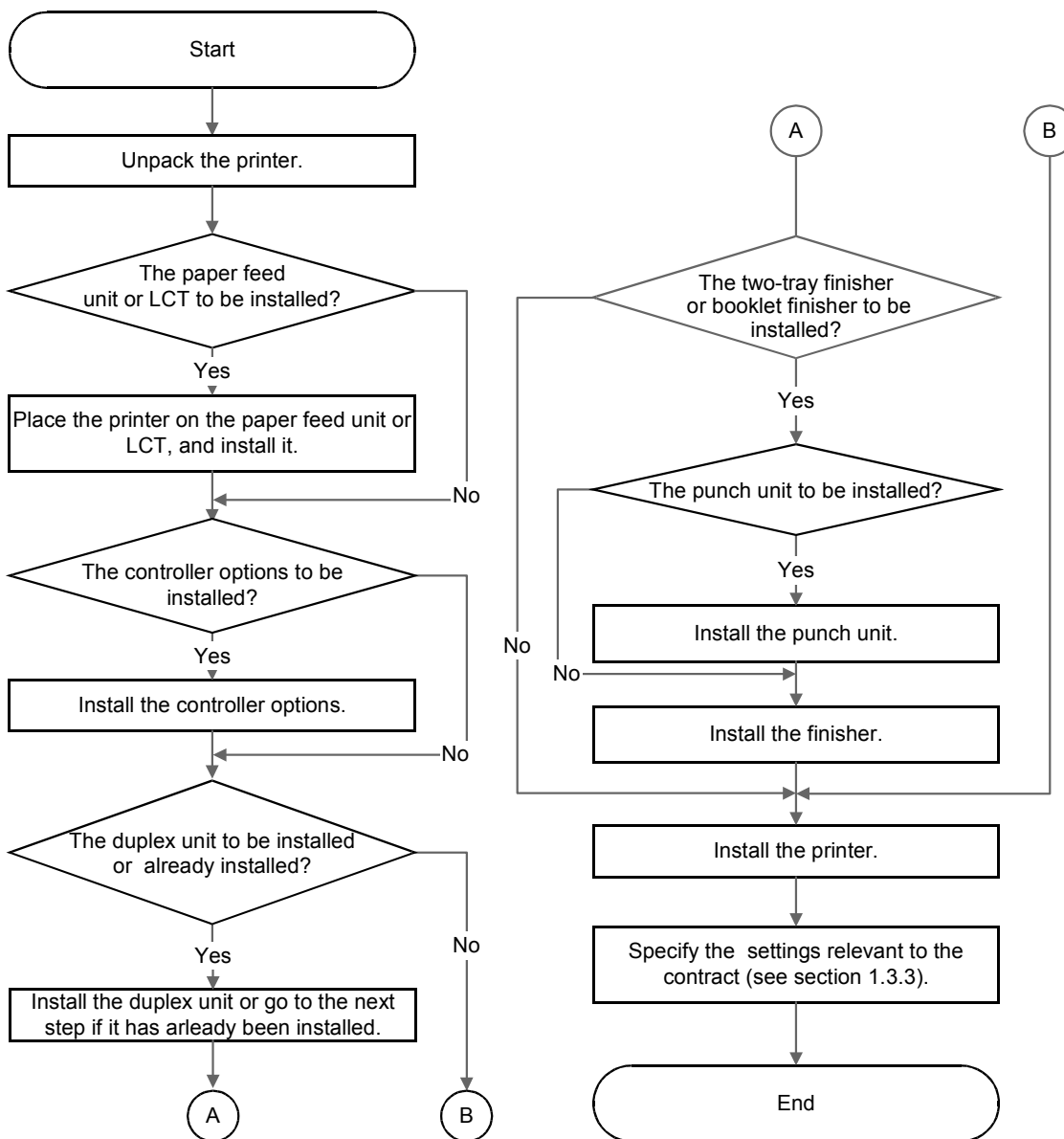

G130I505.WMF

The two-tray finisher and the booklet finisher require ① the duplex unit and ② an optional paper tray unit or the LCT. Each punch unit is for the two-tray finisher or the booklet finisher.

1.3.3 INSTALLATION AND SETTINGS

Refer to the Operating Instructions for the installation procedure. Make the necessary settings for the service contract after you install the printer. Use caution when you make the settings.

1. Check the contract type carefully before you do steps 2 and 3. You cannot change some settings back again if you make an incorrect setting.
2. You must enable Meter Charge (SP5-930-001) for any meter click counter contract. The default is "OFF" (disabled).
3. If you set Meter Charge to "ON", you must set Counter Methods (SP5-045) (developments/prints) in accordance with the contract (☛ 5.3.1). You cannot change the setting back again if you change the setting from "Prints" (default) to "Developments."

The table shows the SP Mode settings related to service contracts.

Service Program	Function
Meter Charge > ON/OFF (SP5-930-001)	Enables or disables the Meter Charge. (Default: OFF [Disabled]) When enabled: <ul style="list-style-type: none"> • The Counter menu appears immediately after you push the Menu key. The Counter Method (SP5-045) sets the type of the counter. • You can print the counter from the Counter menu. When disabled: <ul style="list-style-type: none"> • The Counter menu is not shown.
Meter Charge > Menu (SP5-930-003)	Enables or disables the PM Alert for the PCUs, development units, and fusing unit. (Default: Click 1 [Enabled]) When the PM Alert is enabled, a message is displayed when one of the units needs to be replaced.
Meter Charge > Paper Feed (SP5-930-004)	Enables or disables the PM Alert for the paper feed rollers. (Default: No Alert [Disabled])
Meter Charge > Paper Transfer (SP5-930-005)	Enables or disables the PM Alert for the transfer unit and transfer-cleaning unit. (Default: No Alert [Disabled])
Counter Method (SP5-045)	Tells the counter when to count (each development or each print). (Default: 1 [Prints])
Double Count (SP5-104)	Specifies whether the counter increase by +1 or by +2 when the paper size is A3 or 11" x 17". (Default: OFF [by +1])
Telephone Number Setting > Service (SP5-812-001)	Shows or sets the telephone number of the service representative.
Telephone Number Setting > Fax Telephone Number (SP5-812-002)	Shows or sets the fax number of the service station. The number is printed on the counter list when the Meter Charge is enabled. The user can send a fax message with the counter list.

1.3.4 MOVING THE MACHINE

⚠ CAUTION

Make sure that the transfer belt is in its correct position before you move the printer. Otherwise the transfer belt and the black PCU can get damaged.

NOTE: This section assumes that you manually move the machine to a different floor in the same building. See section 1.3.5 if you use transportation equipment.

The supports on the paper feed unit or LCT make it difficult to move the machine. You can remove them when necessary.

1. Check that the transfer belt is in the correct position.
2. Remove the supports [A] from both sides (🔧 x 2 for each).

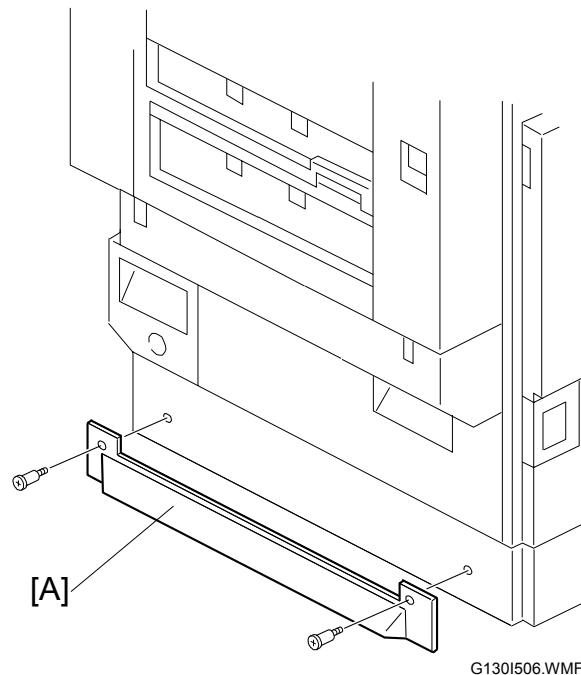

CAUTION: Install the supports again after you move the machine. If not, the machine can tilt when you draw out a paper tray or while you service the printer.

1.3.5 TRANSPORTING THE MACHINE

Read this section when you use transportation equipment to move the machine. When you manually move the machine to a different floor in the same building, see section 1.3.4.

Necessary Adjustment after Transportation

After you install the machine at a new location, do the Line Adjustment (SP5-993-002) or the Auto Adjustment (Menu > Maintenance > Color Regist. > Auto Adjust). When you do one of these programs, make sure that the tray fences are set correctly. If not set correctly, tray fences can make color images shift.

Preparing the Printer**⚠ CAUTION**

Make sure that the transfer belt is in its correct position before you move the printer. If not, the transfer belt and the black PCU can get damaged.

1. Check that the transfer belt is in its correct position.
2. Remove the supports (☛ 1.3.4).
3. Remove the toner bottles to not let toner flow into the toner supply tubes when you move the machine. This can cause the tube to get clogged with toner.
4. Put air packing into the toner cartridge holders to protect the toner supply entrances. This does not let toner flow out to the toner cartridge holders.

5. Set the lock pin [A] (which comes with the machine) in the transfer belt unit.

NOTE: The lower end of the transfer belt smoves. The surface of the belt and PCU can get damaged by the friction between them if you transport the machine without locking the belt.

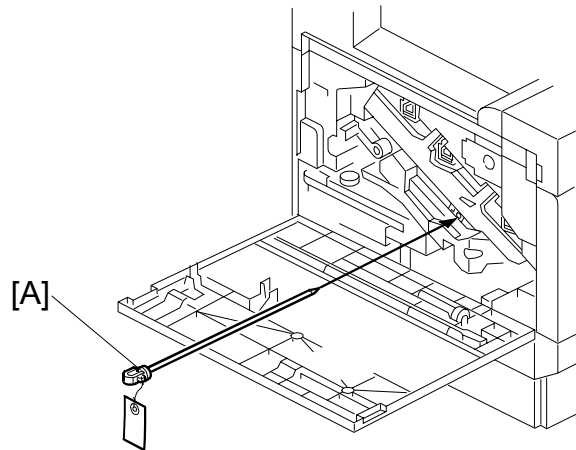

G130I507.WMF

6. Make sure there is no paper left in the paper trays. The fix down the bottom plates with a sheet of paper and tape.
7. Empty out the waste toner bottle. Then attach securing tape not to let the bottle from come out.

8. Turn the release lever [A] counterclockwise to its lowermost position. (The lever does not stay in this position if you do not hold it.) Keep the lever in this position with tape.

NOTE: The release lever lifts the transfer belt up and presses it against the black PCU. The surfaces of the belt and PCU can get damaged by the friction between them if you transport the machine with the two units in this position.

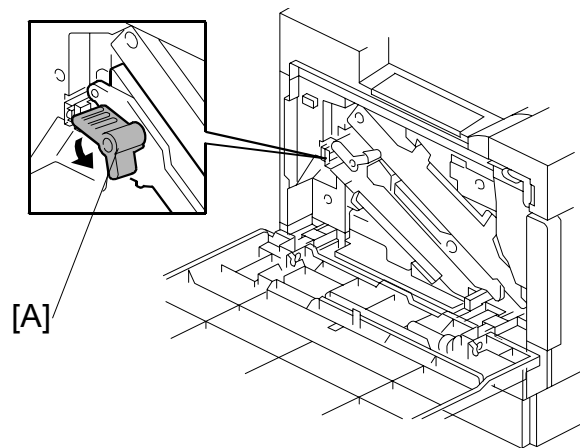

G130I508.WMF

9. Attach shipping tape to the covers and doors. Then shrink-wrap the machine tightly.

1.4 OPTIONAL TRAY UNIT

1.4.1 TWO-TRAY FINISHER

Accessory Check

Check the accessories and their quantities against the following list.

Description	Q'ty
1. Duplex-unit support.....	1
2. Tray.....	1
3. Link rail.....	1
4. Link-rail holder	1
5. Long screw M4x12.....	6
6. Short screw M4x8	2

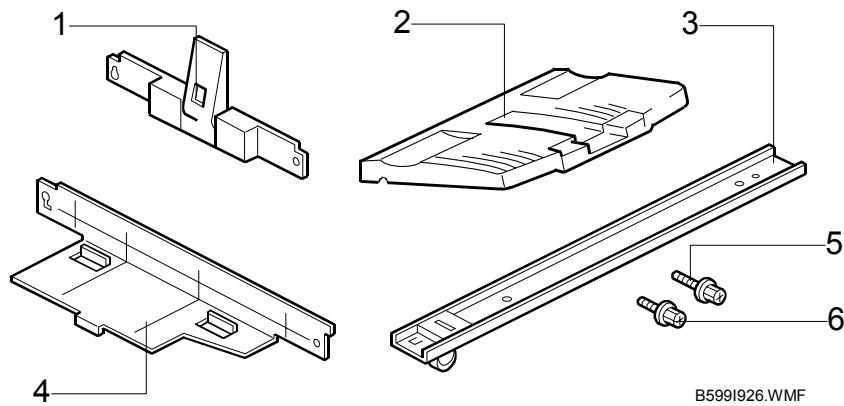

INSTALLATION PROCEDURE

NOTE: This installation procedure uses the following symbols.



: Screw



: Connector

⚠ CAUTION

Turn off the main switch of the printer and unplug its power cord before you start the installation procedure.

1. Remove all tape. Check that no tape remains inside the front cover and on the left cover.
2. Fold the external tray [A].

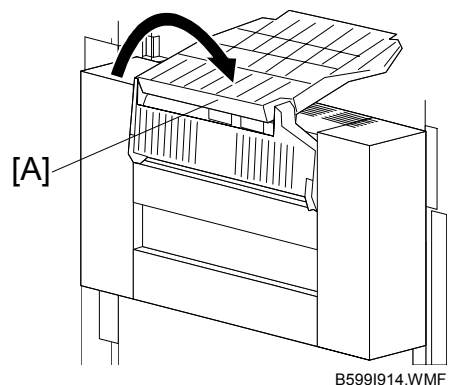

3. Remove the support [A] on the left side (⌀ x 2).

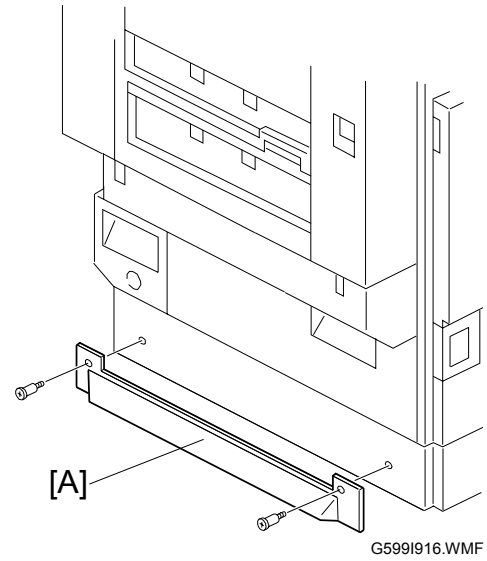

4. Set the link rail [B] on the link-rail holder [C].
5. Install the link-rail holder (with the link rail) to the printer [D] (Long screw x 2).

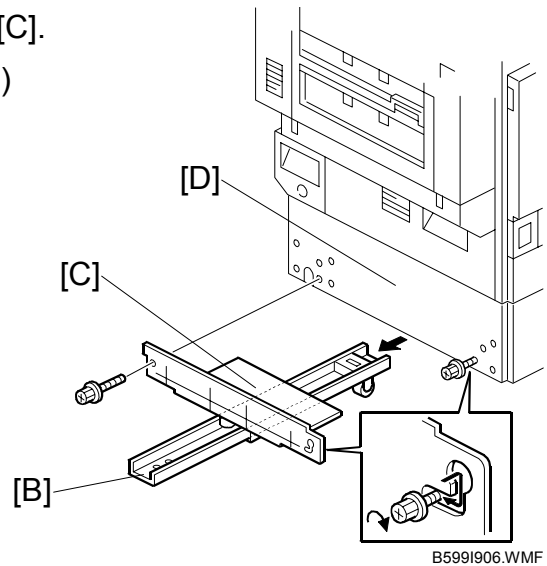

6. Install the duplex-unit support [E] to the printer (Long screw x 3).

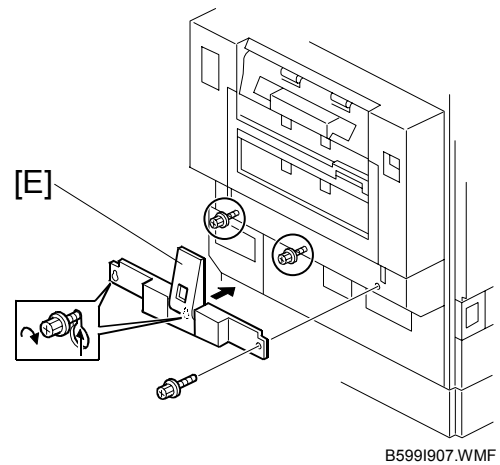

7. Adjust the position of the connection bracket [A] as necessary (Screw x 2):
 - Upper position for the printer with the two-tray paper feed unit or LCT
 - Lower position for the printer with the one-tray paper feed unit

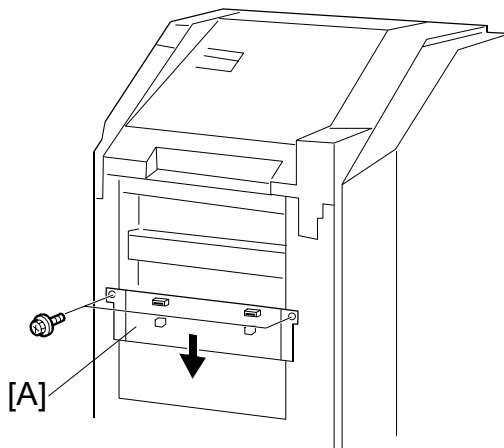

B5991908.WMF

8. Connect the finisher [B] with the printer (Long screw x 1).
9. Connect the finisher cable to the connector of the printer.

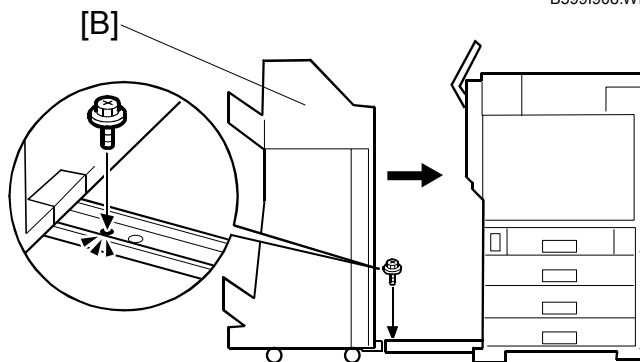

B5991911.WMF

10. Install the two trays [C] (Short screw x 1 for each).
11. Extend the external tray of the printer (see step 2).
12. Turn the main switch on and check the operation.

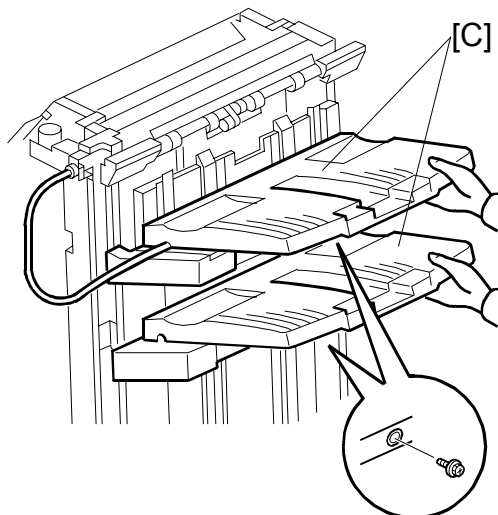

B5991910.WMF

1.4.2 PUNCH UNIT

Accessory Check

Check the quantity and condition of the accessories.

Description	Q'ty
1. Punch unit.....	1
2. Sensor arm	1
3. Spring	1
4. Screw M3 x 6.....	2
5. Step screw.....	2
6. Hopper.....	1
7. Spacer (2 mm).....	1
8. Spacer (1 mm).....	2

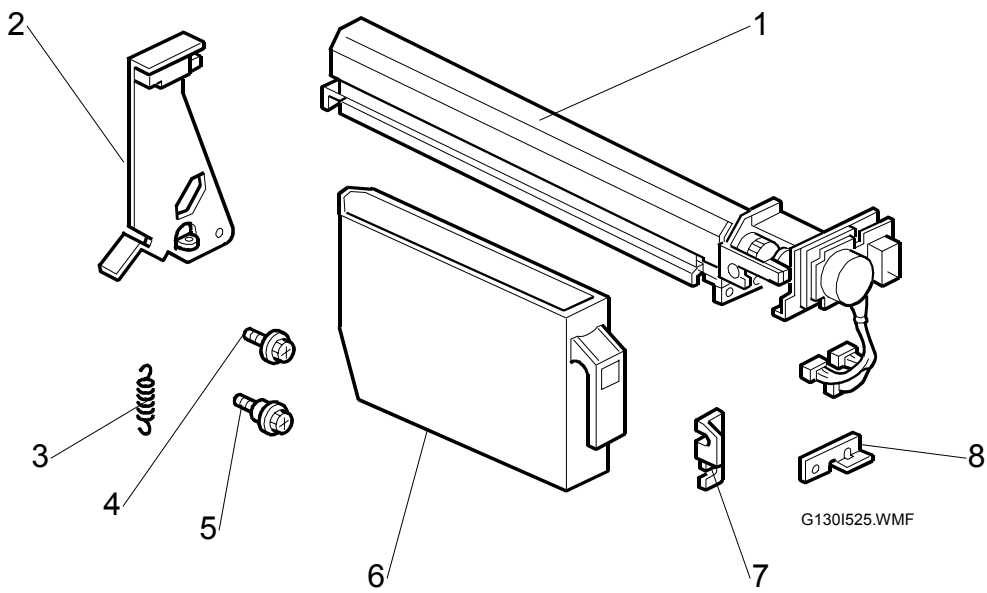

Installation Procedure**⚠ CAUTION**

Switch off the main machine and unplug its power cord. If the two-tray finisher has been installed, disconnect it and pull it away from the machine.

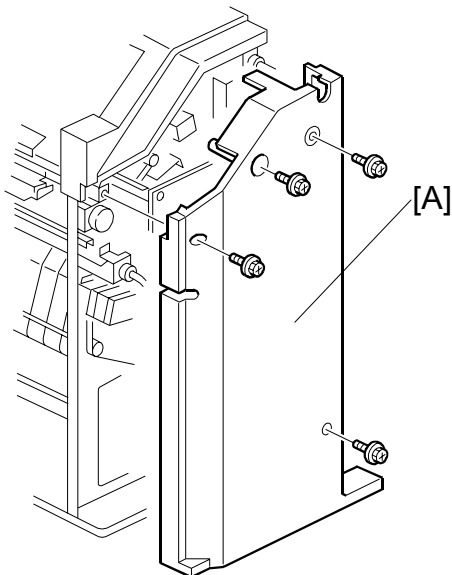

G1301526.WMF

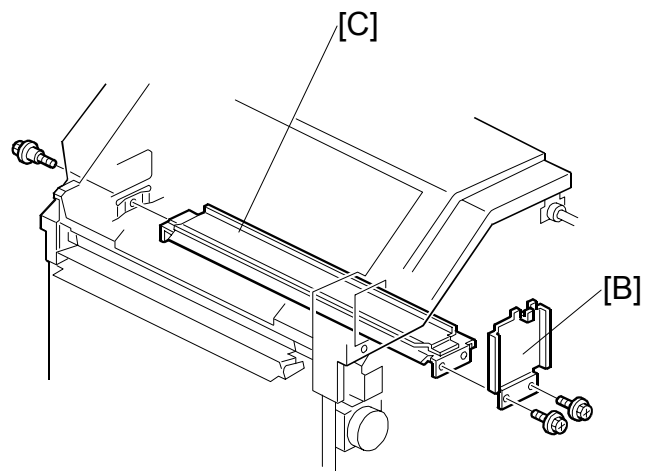

G1301527.WMF

1. Unpack the punch unit and remove all tapes and shipping retainers.
2. Open the front door and remove the rear cover [A] (⚙ x 4).
3. Remove the bracket [B] (⚙ x 2) and paper guide [C] (stepped ⚙ x 1).

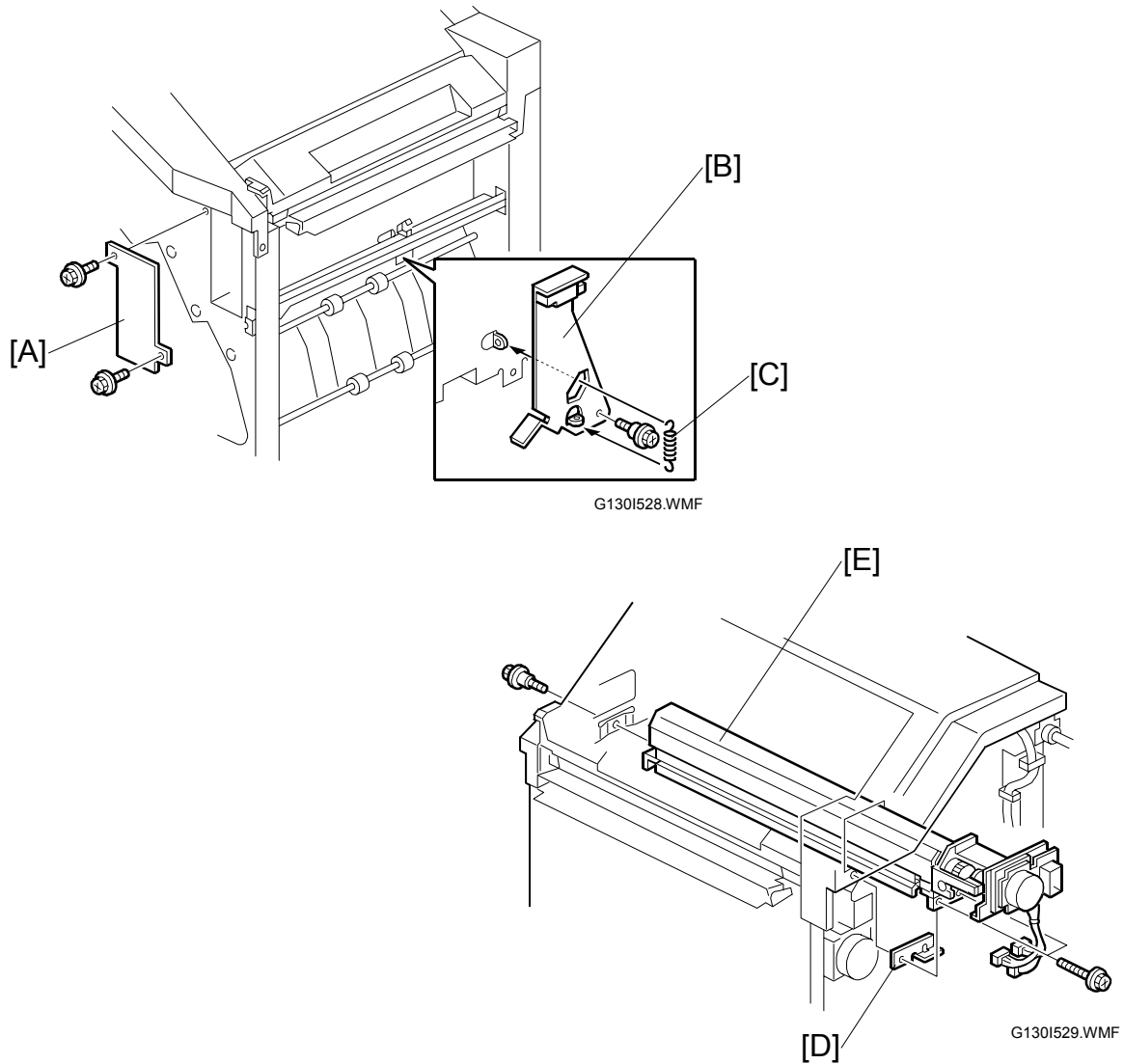

4. Remove the hopper cover [A] (⚙ x 2).
5. Install the sensor bracket [B] (stepped ⚙ x 1).
6. Install the spring [C].
7. Install the 2 mm spacer [D].
8. Install the punch unit [E] (⚙ x 2, stepped ⚙ x 1).

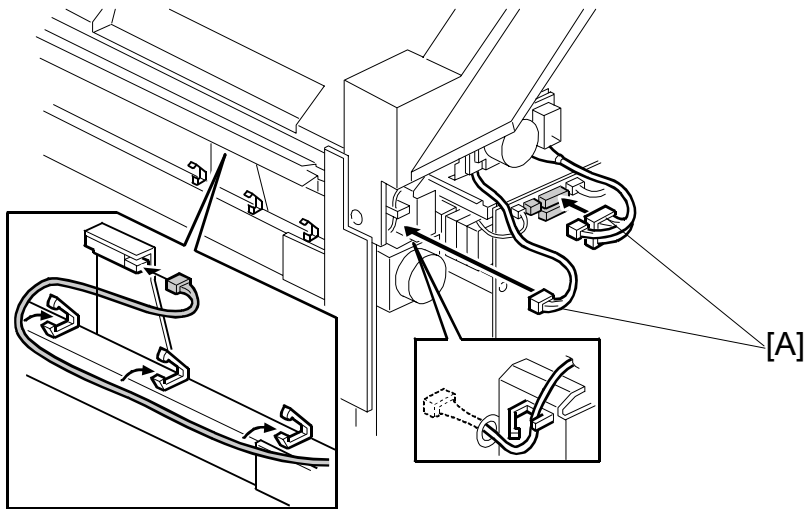

G130I530.WMF

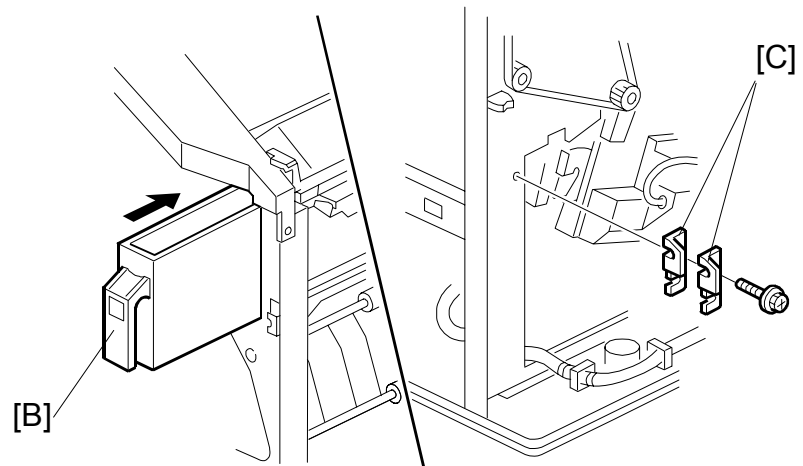

G130I531.WMF

9. Connect the harnesses [A] and clamp them as shown.
10. Slide in the hopper [B].
11. Fasten the two 1-mm spacers [C] to the rear frame for future adjustment.
NOTE: The spacers are used to adjust the horizontal positioning of the punch holes.
12. Reassemble the finisher and check the punch operation.

1.4.3 BOOKLET FINISHER

Accessory Check

Check the quantity and condition of the accessories.

Description	Q'ty
1. Regular tray	1
2. Rail holder.....	1
3. Magnet catch–rear	1
4. Magnet catch–front	1
5. Duplex-unit support.....	1
6. Rail joint	1
7. Screw M4 x 12	6
8. Screw M4 x 6	8
9. Screw M3 x 14	4
10. Rail	1
11. Stapler unit.....	1
12. Staple cartridge.....	1
13. Pad	3

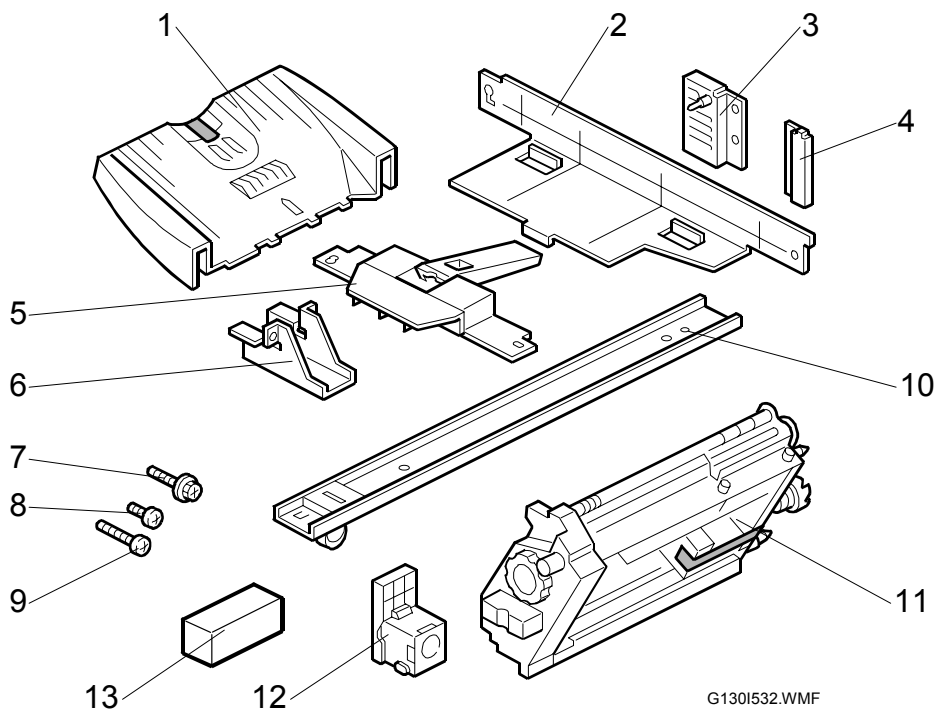

NOTE: Make sure that you keep the pads. The pads are white and made of Styrofoam.

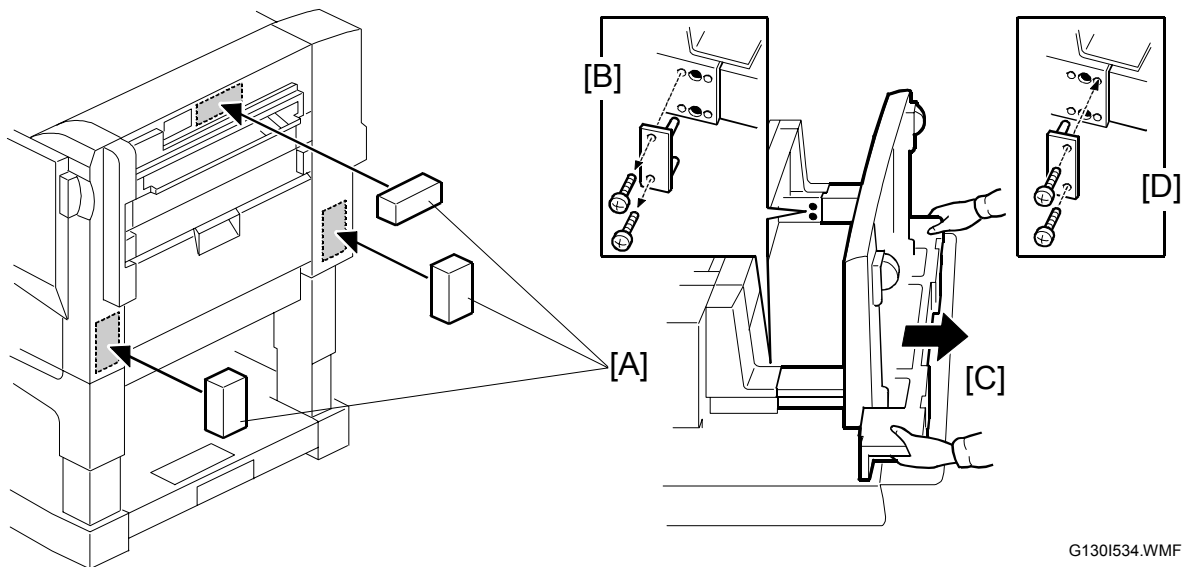
Adjusting the Height

G1301533.WMF

G1301534.WMF

1. Check the type of the optional paper tray:
 - If the optional two-tray paper feed unit or the optional LCT is installed, go to step 2.
 - Go to "Main Body" if either of them is not installed.
2. Tape the pads [A] to the right-hand side of the machine.
3. Put the machine on its right-hand side.
4. Remove the adjuster plates [B] (⌀ x 2).
5. Change the height [C].
6. Install the adjuster plates again [D].
7. Remove the machine out of the box and stand it up.
8. Check that the height is correct, and remove the pads.

Main Body

1. Remove all tape and padding.

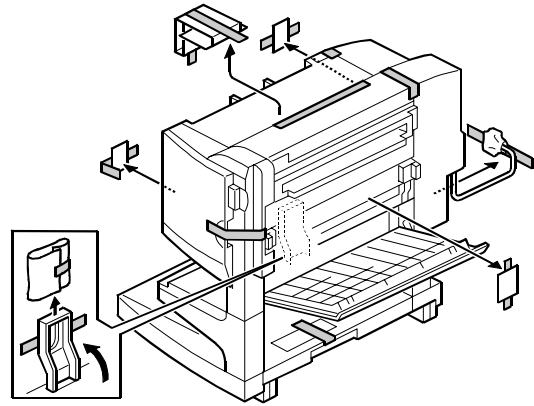

G130I535.WMF

2. Remove the screw cover [A].
3. Install the rail joint [B] (⌀ x 4).
4. Install the screw cover again.

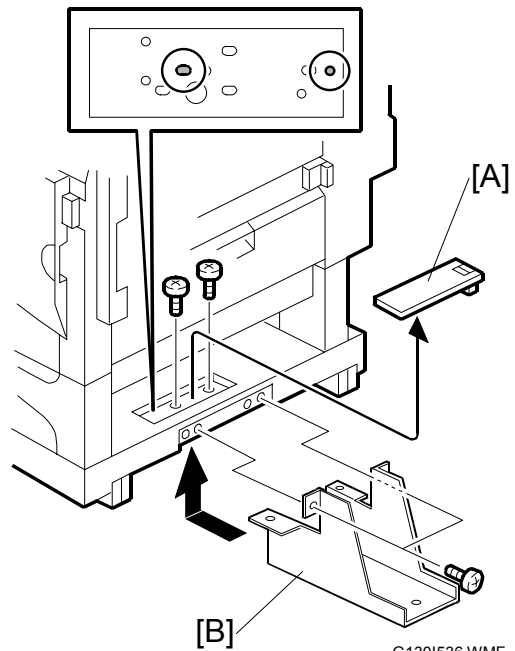

G130I536.WMF

5. Install the regular tray [C] (⌀ x 4).

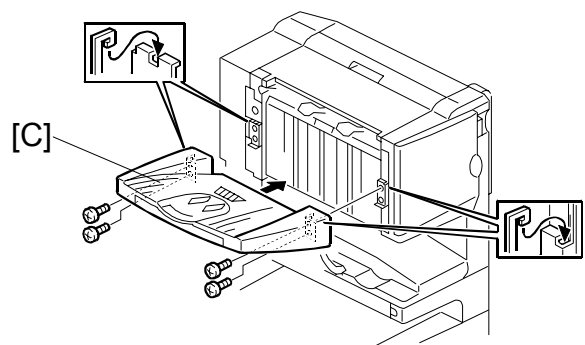

G130I537.WMF

6. Install the magnet catches [A][B] (⚙ x 2 for each).
7. Install the duplex-unit support [C] (⚙ x 3).

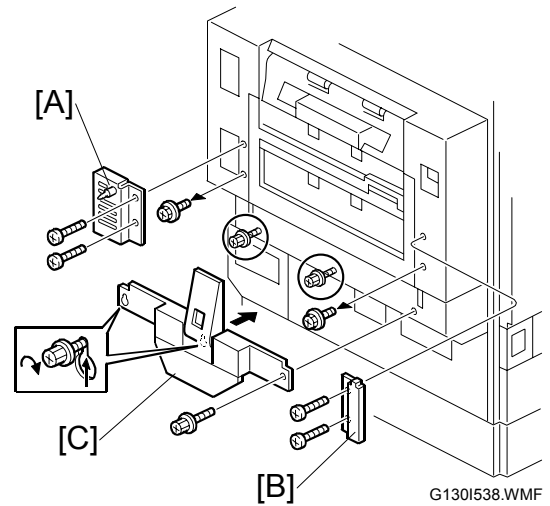

8. Remove the support on the left side [D] (⚙ x 2).

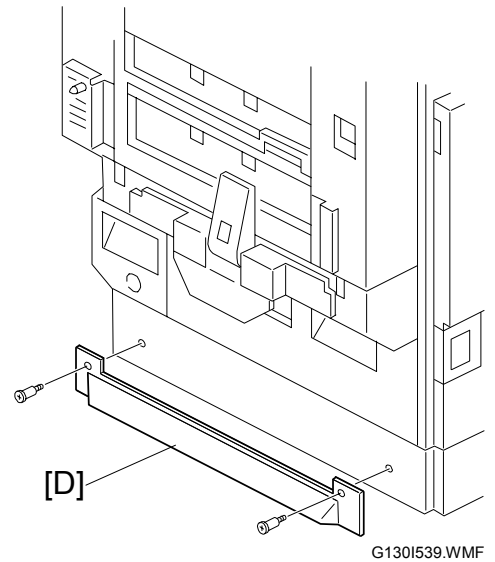

9. Set the rail [E] through the rail holder [F].
10. Install the rail holder (with the rail) to the printer (⚙ x 2).

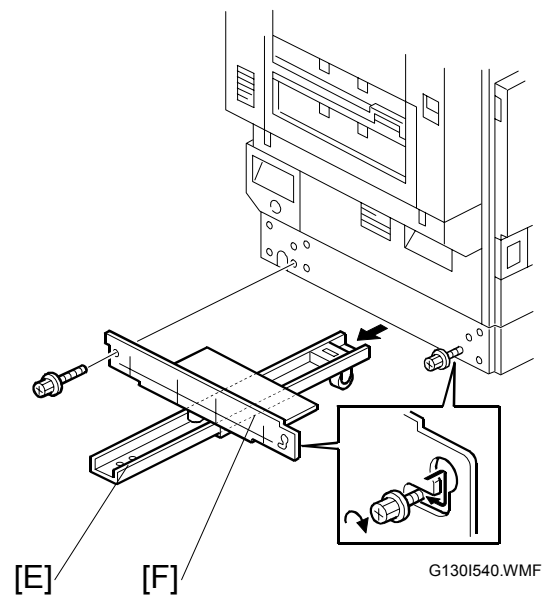

11. Connect the booklet finisher unit to the printer (⚙ x 1).

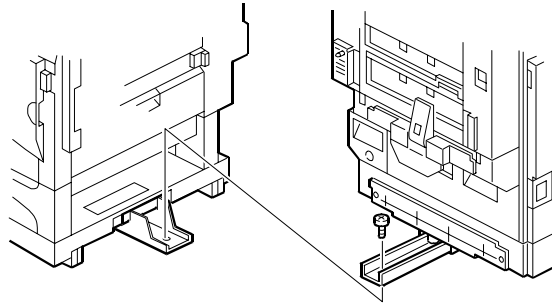

G130I541.WMF

12. Install the stapler unit [A].

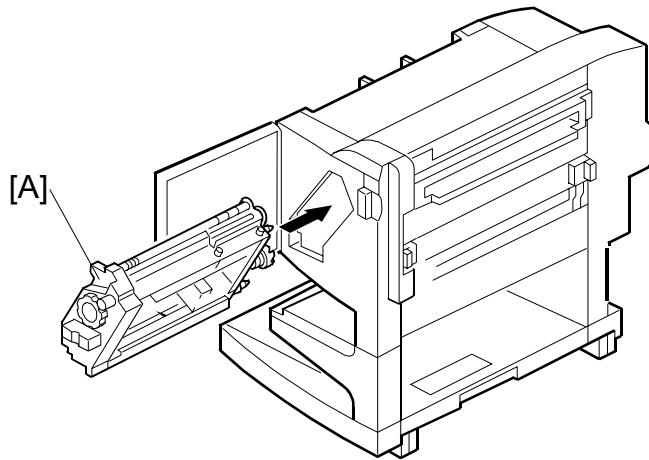

G130I542.WMF

13. Turn the knob [B] clockwise until the staple-cartridge holder [C] reaches the front-most position.
14. Install the staple cartridge [D] firmly to the staple-cartridge holder.

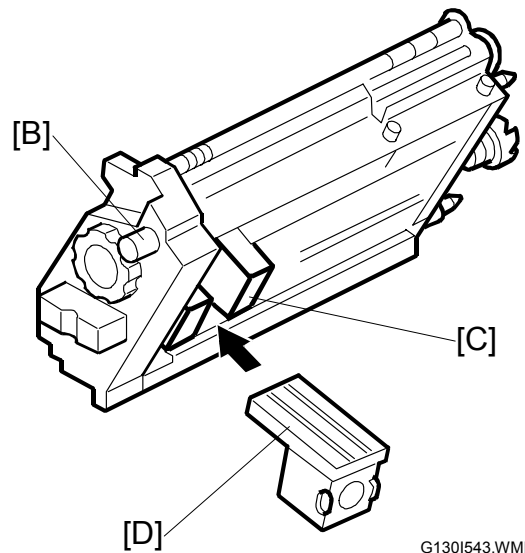

G130I543.WMF

15. Turn on the main switch and check the operation.

1.4.4 OPTIONAL PUNCH UNIT

Accessory Check

Check the quantity and condition of the accessories.

Description	Q'ty
1. Punch unit.....	1
2. Decal	1
3. Screw M4 x 6 (with the base).....	1
4. Cable	2

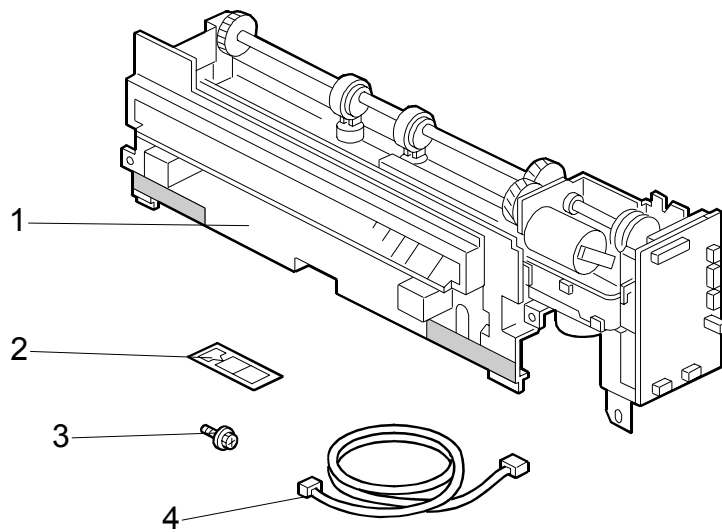

G130I544.WMF

Installation Procedure

1. Remove the front lower cover [A]
( x 2).

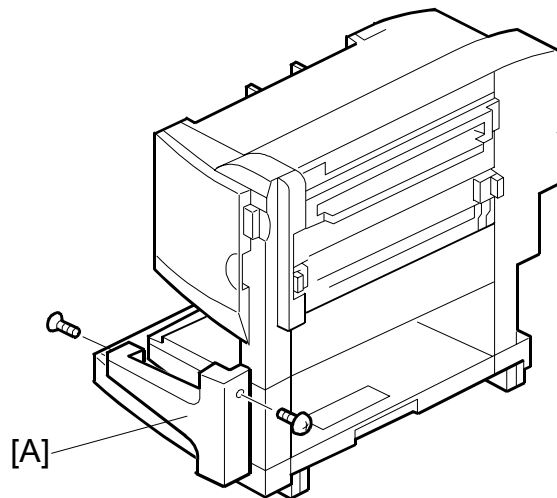

G130I545.WMF

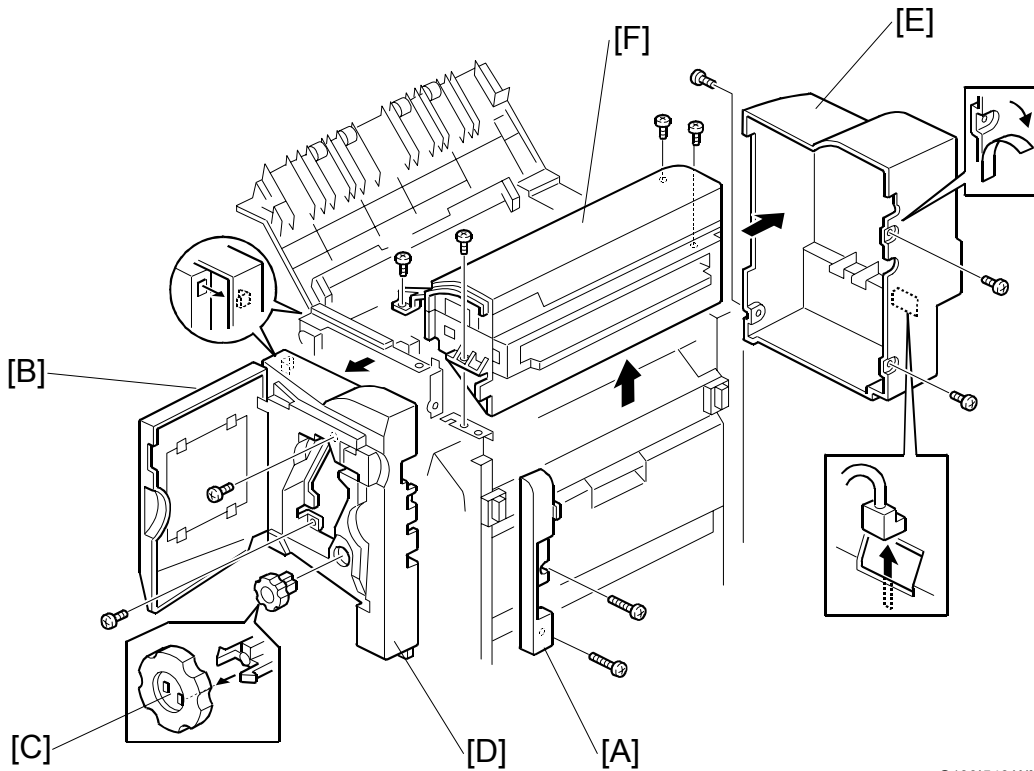

G1301546.WMF

2. Remove the joint guard [A] (⌀ x 2).
3. Open the front door [B].
4. Release the stopper and remove the knob [C].
5. Remove the front cover [D] (⌀ x 2).
6. Remove the rear cover [E] (⌀ x 3).
NOTE: Do not damage the Mylar when you remove the screw.
7. Remove the right top cover with the paper entrance cover [F] (⌀ x 4).

8. Remove the right top cover [A] from the paper entrance cover [B].

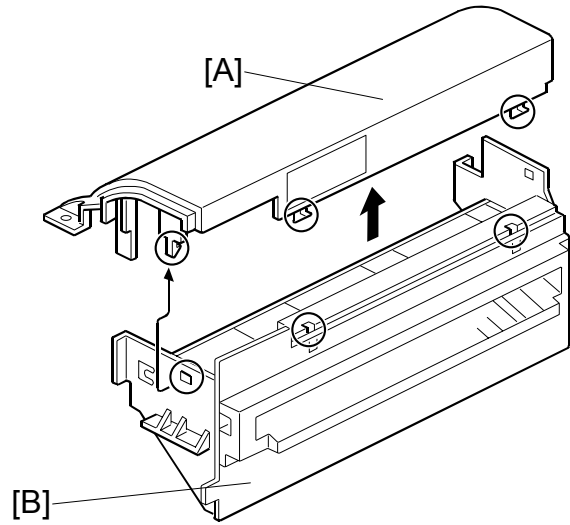

G130I547.WMF

9. Install the punch unit [C] (⌀ x 2, 1 screw with the base [D])

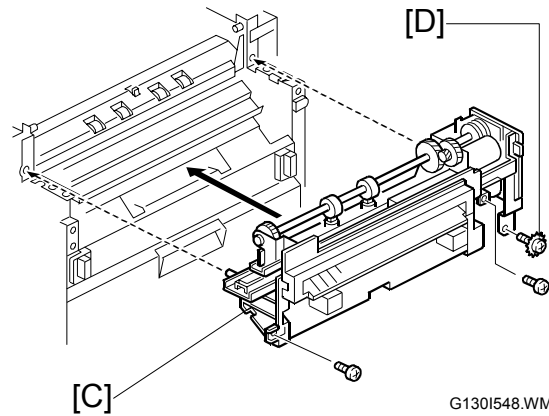

G130I548.WMF

10. Install the right top cover [E] (⌀ x 2).

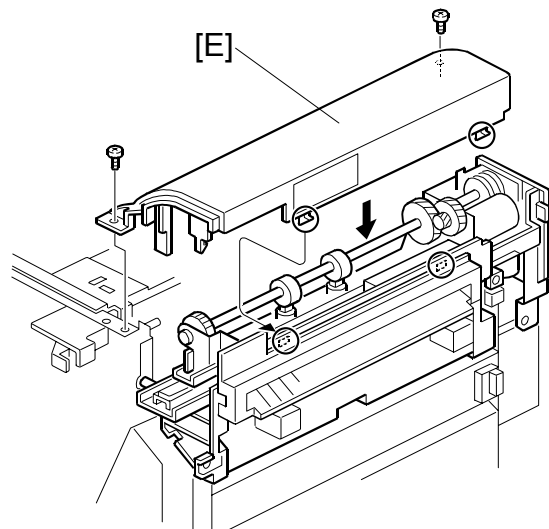

G130I549.WMF

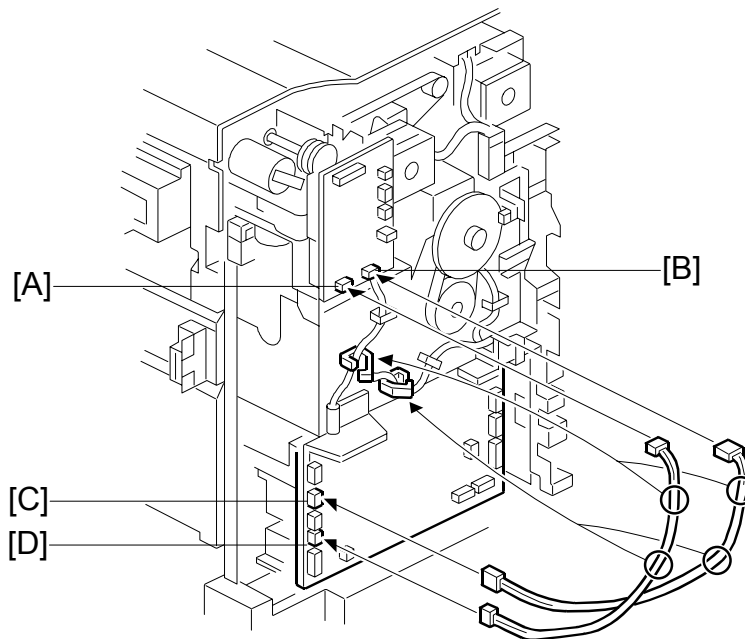

G130I550.WMF

11. Install the cable to the connectors as follows:

- J1003 (punch unit) [A] to CN12 (booklet finisher unit) [D]
- J1004 (punch unit) [B] to CN14 (booklet finisher unit) [C]

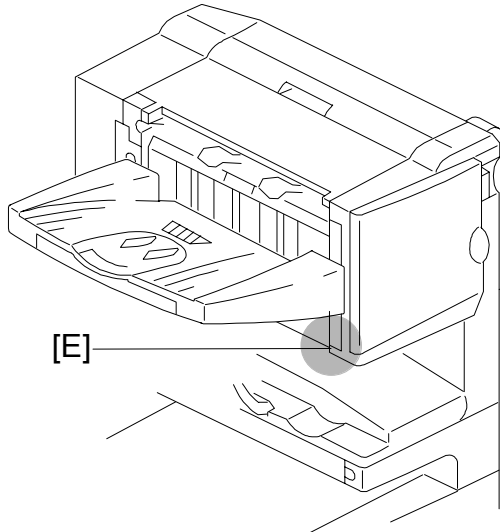

G130I551.WMF

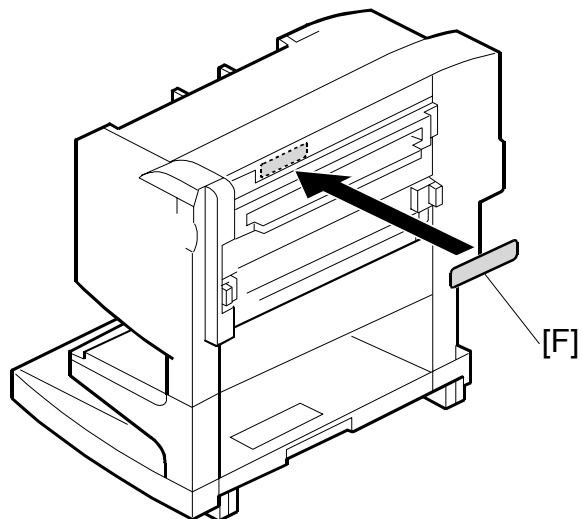

G130I552.WMF

12. Fasten the cable with the clamps.

13. Reassemble the booklet finisher unit.

NOTE: Check that the side guide and the front cover correctly join with each other [E].

14. Attach the decal [F].

15. Turn on the main switch and check the punch operation.

2. PREVENTIVE MAINTENANCE

2.1 USER MAINTENANCE

Maintenance Kit

The table shows the maintenance kits for the user.

Kit	Component	Expected Yield (Prints)
A	Color PCU (3 PCUs for CMY)	40 k
B	Color Development Unit (3 units for CMY)	80 k
C	Fusing Unit (without Oil Supply Unit)	80 k
D	Black Development Unit and Dust Filter	80 k
E	Waste Toner Bottle	40 k
F	Black PCU	40 k
H	Paper Feed Rollers	150 k

NOTE: The yield is calculated for these conditions: A4 (LT) LEF, 5% image coverage ratio, 3 prints per job.

PM Alert Display

This machine can show a PM Alert (an error message) when a unit or component must be replaced. The table shows the SPs related to PM Alerts.

Service Program	Function
Meter Charge > Menu (SP5-930-003)	Enables or disables the PM Alert for the PCUs, development units, and fusing unit. (Default: Click 1 [Enabled])
Meter Charge > Paper Feed (SP5-930-004)	Enables or disables the PM Alert for the paper feed rollers. (Default: No Alert [Disabled])

The machine stops operation if the user does not replace the waste toner bottle when the machine tells the user to do this.

New Unit Detection

When the user replaces a unit or component that is a part of a maintenance kit, the machine automatically detects the unit or component except the paper feed rollers. The related counter(s) (one or some of SP7-803-001 to 049) will be set to zero.

PM Table

Symbol key: C: Clean, R: Replace, L: Lubricate, I: Inspect

Main Unit

Item	40K	80K	150K	EM	Remarks
Black PCU	R				
Color (Y/M/C) PCU	R				
Black Development Unit		R			
Color (C/M/Y) Development Unit		R			
Fusing Unit		R			
Pick-up Roller			R		
Feed Roller			R		
Separation Roller			R		
Waste Toner Bottle	R				
Dust Filter		R			
Circuit Breaker				I	At least once a month

Punch Kit

Item	10K				EM	Remarks
Chads	I					Discard chads.

One-tray Paper Feed Unit (500 sheets x 1)

Item	100K	150K	250K	1,000K	3,000K	EM	Remarks
Relay Roller						C	Damp cloth
Bottom Plate Pad						C	Damp cloth
Pick-up Roller		R					
Feed Roller		R					
Separation Roller		R					

Two-tray Paper Feed Unit (500 sheets x 2)

Item	100K	150K	250K	1,000K	3,000K	EM	Remarks
Relay Roller						C	Damp cloth
Bottom Plate Pad						C	Damp cloth
Pick-up Roller		R					
Feed Roller		R					
Separation Roller		R					

LCT (2000 sheets)

Item	100K	150K	250K	1,000K	3,000K	EM	Remarks
Relay Roller						C	Damp cloth
Bottom Plate Pad						C	Damp cloth
Pick-up Roller		R					
Feed Roller		R					
Separation Roller		R					

2.2 SERVICE MAINTENANCE

PM Counter Reset

Reset the related PM Counter after you replace a unit or component that is not a part of a maintenance kit (☛ 2.1). To do this, use PM Counter Reset (SP7-804). The table shows the service programs that you must use.

SP7-804-011	By-pass Tray Feed Roller	SP7-804-015	Paper Feed Tray 4 Feed Roller
SP7-804-012	Paper Feed Tray 1 Feed Roller	SP7-804-017	Transfer Unit
SP7-804-013	Paper Feed Tray 2 Feed Roller	SP7-804-018	Transfer Cleaning Unit
SP7-804-014	Paper Feed Tray 3 Feed Roller		

Preventive
Maintenance

PM Table

Symbol key: C: Clean, R: Replace, L: Lubricate, I: Inspect

Main unit

Item	100K	150K	250K	1,000K	3,000K	EM	Remarks
Transfer Unit				R			
Transfer Cleaning Unit			R				
By-pass Feed Roller		R					
By-pass Pick-up Roller		R					
By-pass Separation Roller		R					

Two-tray Finisher

Items	100K	150K	250K	1,000K	3,000K	EM	Remarks
Rollers						C	Damp cloth
Discharge Brush						C	Dry cloth
Sensors						C	Blower brush
Jogger Fences						I	Replace if required.

3. REPLACEMENT AND ADJUSTMENT

CAUTION

Turn off the main switch and unplug the machine before you do the procedures in this section.

3.1 SPECIAL TOOLS

Part Number	Part Name	Q'ty
B6455010	SD Card	1
B6456700	PCMCIA Card Adapter	1
B6456800	USB Reader/Writer	1
A029 9387	Digital Multimeter–FLUKE87	1
G021 9350	Loop-back Connector–Parallel	1
C401 9503	20X Magnification Scope	1
A2579300	Grease Barrierta–S552R	1
52039501	Silicon Grease G-501	1

Replacement
Adjustment

3.2 IMAGE ADJUSTMENT

3.2.1 REGISTRATION

Image Area

The image area shown in the illustration must be guaranteed. So make sure that the registration is adjusted within the adjustment standard range as described below.

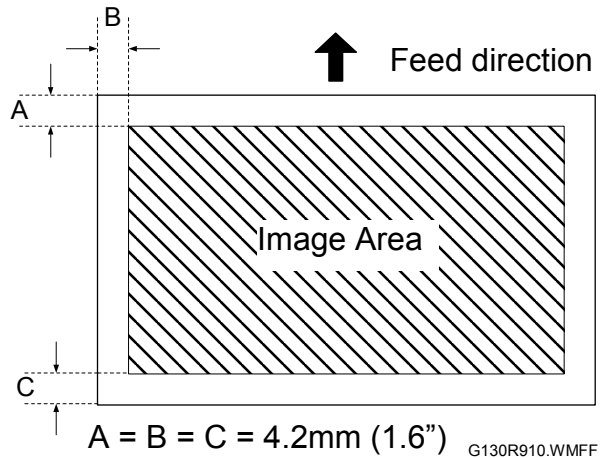

Leading Edge

Adjusts the leading edge registration for each paper type and process line speed.

Side to Side

Adjusts the side to side registration for each paper feed station.

NOTE: The side to side registration for the optional paper feed unit, LCT, and duplex unit can be adjusted with SP mode or with the user tools (Maintenance menu).

Adjustment Standard

- Leading edge (sub-scan direction): 3 ± 0 mm
- Side to side (main-scan direction): 2 ± 0 mm

Paper Registration Standard

The registration in both main- and sub-scan directions may fluctuate within the following tolerance.

1st side

- Sub-scan direction: 0 ± 1.5 mm
- Main-scan direction: 0 ± 2 mm

2nd side in duplex

- Sub-scan direction: 0 ± 3 mm
- Main-scan direction: 0 ± 4 mm

Adjustment Procedure

1. Enter SP mode and access SP5-997.
2. Print out the pattern (15: trimming pattern) with SP5-997.
NOTE: Registration may change slightly print by print as shown above.
 Therefore, print a few pages of the trimming pattern for step 3 and 4, and average the leading edge and side-to-side registration values and adjust each SP mode.
3. Perform the leading edge registration adjustment.
 - 1) Check the leading edge registration and adjust it with SP1-001.
 - 2) Select the adjustment conditions (paper type and process line speed).
 - 3) Input the value then press the [Escape] key.
 - 4) Check the leading edge adjustment by generating the trim pattern.
4. Perform the side to side registration adjustment.
 - 1) Check the side to side registration and adjust it with SP1-002.
 - 2) Select the adjustment conditions (paper feed station).
 - 3) Input the value then press the [Escape] key.
 - 4) Check the side to side adjustment by generating the trim pattern.

3.2.2 COLOR REGISTRATION

Line Position Adjustment

Normally, the automatic line position adjustment is executed under a specified condition to optimize the color prints. If color registration shifts, execute "Auto Adjust" with the user tools (Maintenance menu – Color registration) or SP5-993-2 to do the forced line position adjustment. In addition, it is recommended to perform the line position adjustment under the following conditions:

- After transporting or moving the printer (If printers are pre-installed at the workshop and transported to the user location, forced line position adjustment should be done after printer installation is completed at the user location.)
- When opening the drum positioning plate
- When removing or replacing the motors, clutches, and/or gears related to the drum/development/transfer sections
- When removing or replacing the transfer belt or laser optics housing unit

Adjustment of Line Speed for Thick Paper

You must adjust the line speed of the fusing unit (the speed of development motor-K) under the following conditions:

- The color registration shifts more on the trailing edge than on the leading edge.
- This problem has not been solved by the line position adjustment.

Use the following user tool for this adjustment:

- Menu/Maintenance/Color Regist./Fuser Adjust/Thick paper

3.2.3 PRINTER GAMMA

NOTE: Normally, the printer gamma is enough to adjust the color balance to achieve the optimum print output. The gamma correction is only required for fine-tuning to meet the user requirements.

Adjustment Overview

Make the gradation scales on the printout smooth from the highlight to the shadow density. Adjust the CMY gradation scale at the top of the chart by balancing the density of the C, M, and Y gradation scales – the CMY gray scale should change smoothly from minimum to maximum, and there should be no coloration.

For each color, you can adjust 15 points between 0 (lowest density) and 255 (highest density).

The gradation scales marked “Default Value” are printed according to the default gamma settings. The gamma adjustment changes the densities at the adjustable points in the gradation scale. The gradation scale marked “Current Value” shows the current settings.

During the adjustment procedure, compare the “Current Value” gradation scale with the “Default Value” Select the density for each of the 15 adjustable points, excluding points 0 and 255, from the “Default Value” gradation scale.

The NVRAM holds three printer gamma settings, those saved this time (Current), those saved in the preceding adjustment (Previous), and the factory settings (Factory).

Adjustment Procedure

1. Enter SP mode.
2. Select “1. Service”
3. Select “ToneCtlSet” (SP1-101) and load the settings that will serve as the base for the adjustment.
4. Select “ToneCtlSet” (SP1-102), and select the print mode that you are going to adjust.
5. To review the image quality for these settings, choose “PrnColorSheet” (SP1-103) to print out a color calibration test sheet.
6. Select “ToneCtlValue” (SP1-104).
7. Adjust the color density at each of the 15 points for a color (CMY and K).
8. When the density setting is complete for all colors, print out a color calibration test sheet again and make sure that the gradation scale for each printed color is smooth and that the CMY gradation scale is gray. Repeat the adjustment if there is an anomaly.
9. If the adjustment results prove satisfactory, execute “ToneCtlSave” (SP1-105).

3.3 DUPLEX INVERTER UNIT

3.3.1 TOP COVER

1. External tray [A]
2. Open the duplex left cover [B].
3. Top cover [C] (⚙️ x 4)

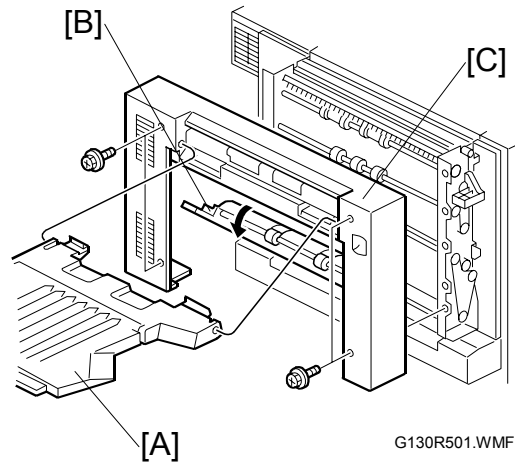

Replacement
Adjustment

3.3.2 DUPLEX INVERTER MOTOR 1 AND CONTROL BOARD

1. Top cover (☛ 3.3.1)
2. Exit tray [A]
3. Duplex unit [B] (⚙️ x 1, ⚙️ x 1)

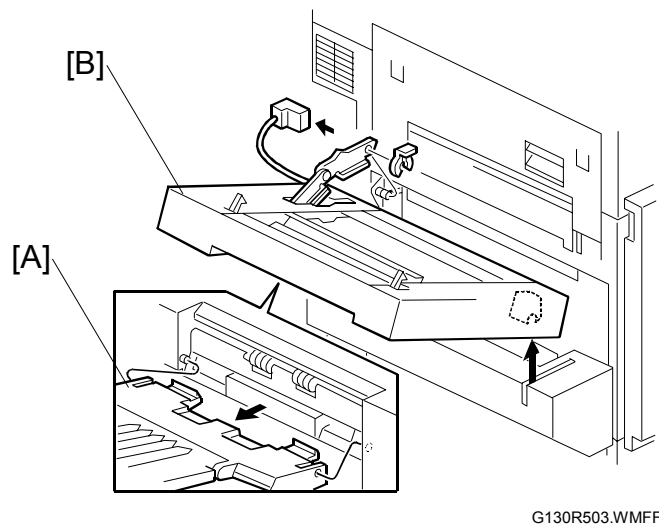

- 4. Inner cover [A] (🔩 x 2)
- 5. Duplex control board bracket [B] (🔩 x 2, 📏 x 7)

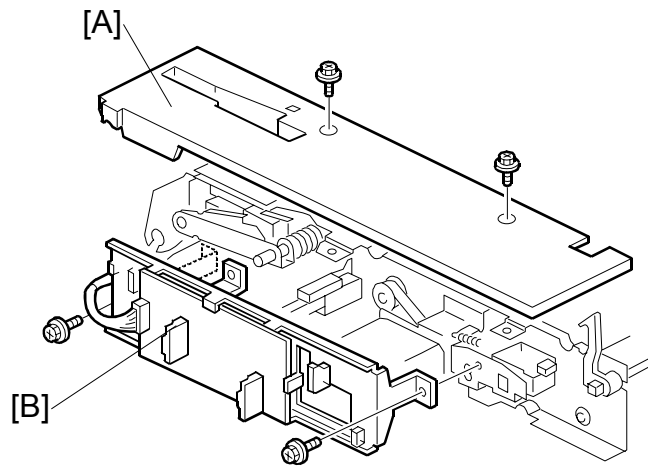

G130R504.WMFF

- 6. Duplex inverter motor 1 [C] (🔩 x 2, 1 timing belt)

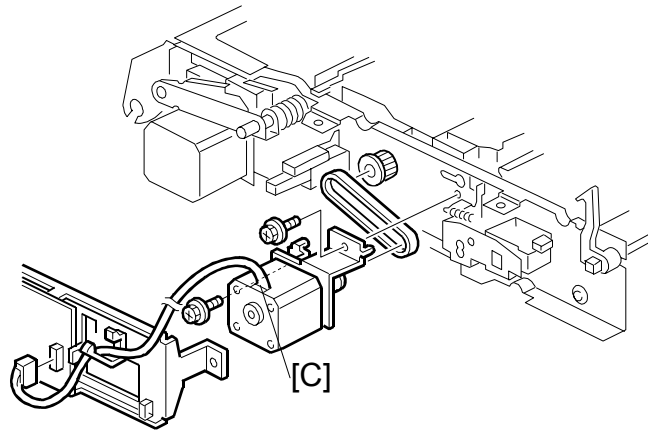

G130R505.WMFF

3.3.3 DUPLEX INVERTER MOTOR 2 AND SWITCH

1. Duplex control board bracket (☛ 3.3.2)
2. Duplex inverter unit switch [A]
(⚙️ x 1, 🛠️ x 1)
3. Duplex inverter motor 2 [B]
(⚙️ x 2, 1 timing belt)

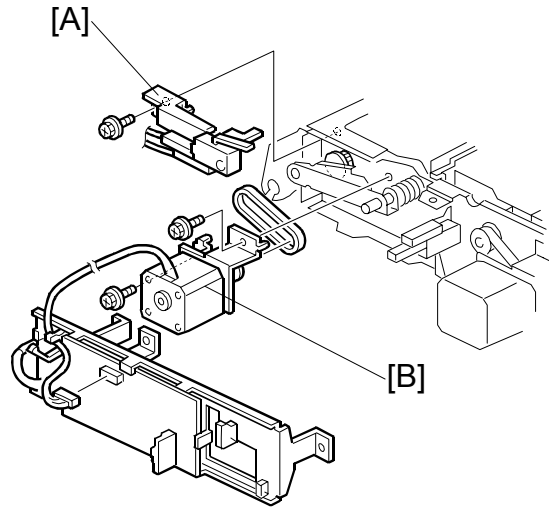

G130R506.WMFF

Replacement
Adjustment

3.3.4 EXIT SENSOR 3 AND DUPLEX INVERTER SENSOR

1. Open the duplex inverter unit [A]
2. Exit sensor 3 [B] (🛠️ x 1)
3. Duplex inverter sensor [C]
(⚙️ x 1, 🛠️ x 2)

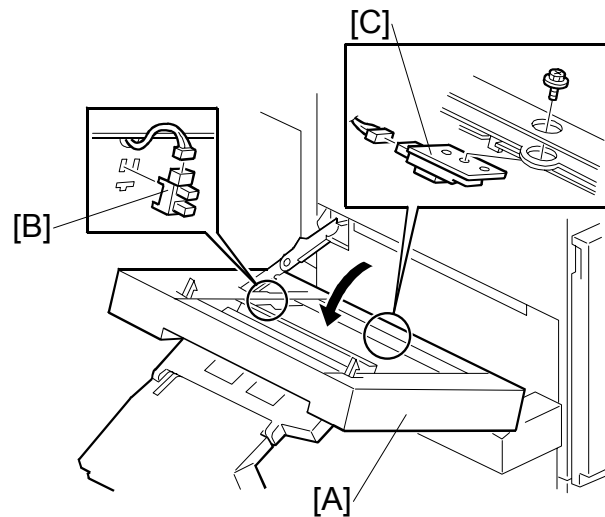

G130R507.WMFF

3.3.5 EXIT SENSOR 1 AND 2

1. Top cover (☛ 3.3.1)
2. Open the duplex unit.
3. Exit sensor 1 [A]
(⚙️ x 1, 🛠️ x 1, 1 bracket)
4. Exit sensor 2 [B] (🛠️ x 1)

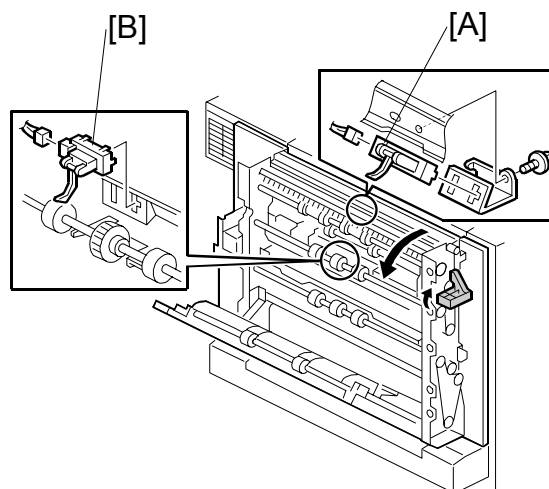

G130R508.WMFF

3.4 DUPLEX FEED UNIT

3.4.1 DUPLEX DRIVE BOARD

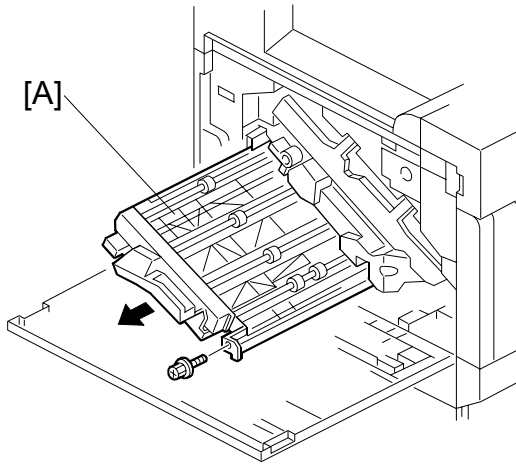

G130R510.WMFF

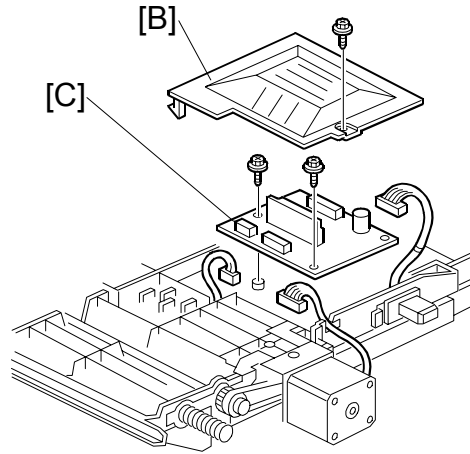

G130R509.WMFF

1. Open the front cover
2. Duplex feed unit [A] (🔩 x 1)
3. Inner cover [B] (🔩 x 1)
4. Duplex drive board [C] (🔩 x 2, 📏 x 3)

3.4.2 DUPLEX FEED MOTOR

1. Duplex feed unit (👉 3.4.1)
2. Inner cover [A] (🔩 x 1)
3. Duplex feed motor [B]
(🔩 x 1, 📏 x 1, 1 timing belt)

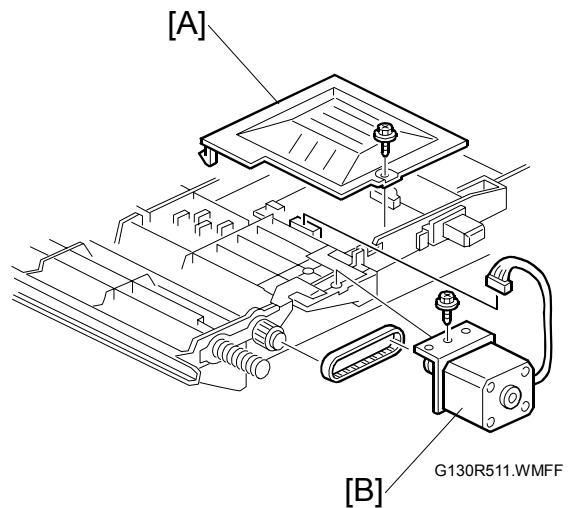

G130R511.WMFF

3.4.3 DUPLEX FEED SENSOR

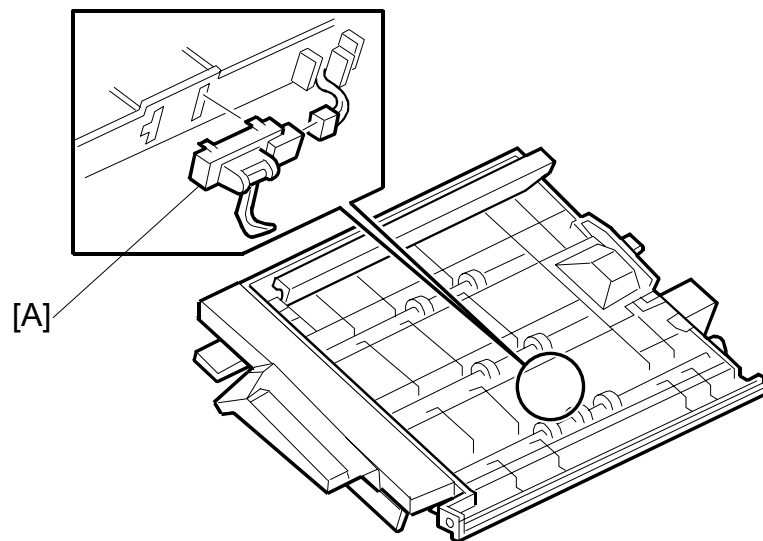

Replacement
Adjustment

G130R512.WMFF

1. Duplex feed unit (☛ 3.4.1)
2. Duplex feed sensor [A] (☛ x 1)

3.5 EXTERIOR COVERS

3.5.1 REAR COVER AND UPPER REAR COVER

1. Rear cover [A] (⚙ x 4, 2 hooks)
2. Upper exit cover [B] (1 hook) if the optional mailbox is not installed.
3. Open the upper right cover [C].
4. Upper rear cover [D] (⚙ x 4)

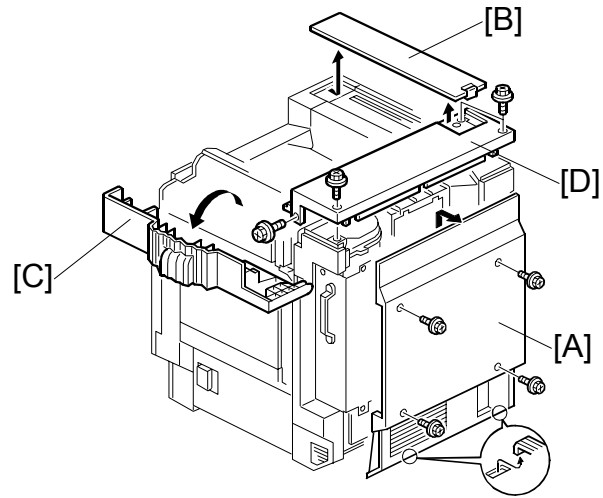

G130R902.WMFF

3.5.2 PAPER EXIT TRAY

1. Paper exit tray [A] (⚙ x 2)

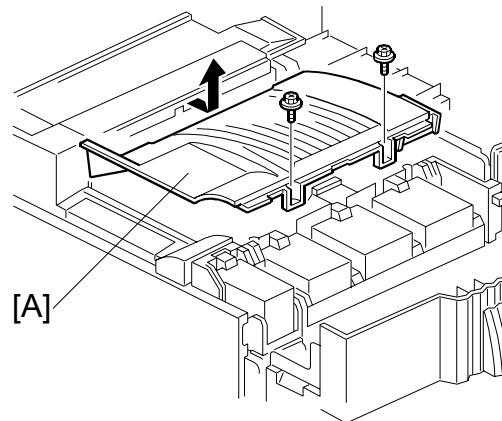

G130R904.WMFF

3.5.3 UPPER RIGHT COVER

1. Right cover [A] (⚙️ x 2)
NOTE: To remove the right cover, open the upper right cover.
2. Upper right cover [B]

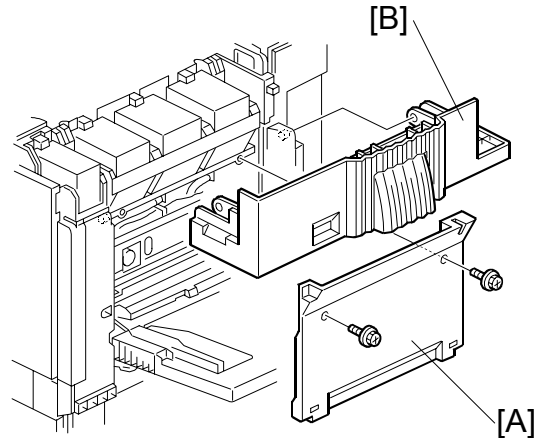

G130R905.WMFF

Replacement
Adjustment

3.5.4 FRONT COVER

1. Front cover [A] (2 pins)

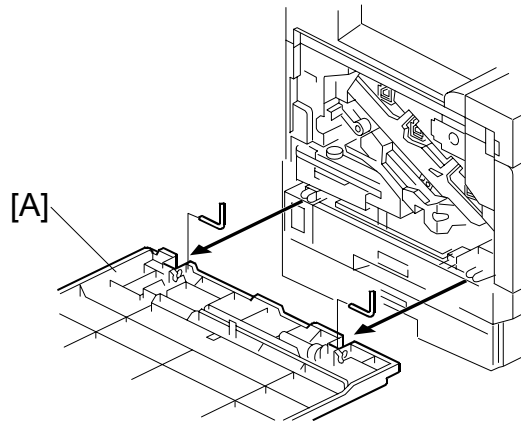

G130R917.WMF

3.5.5 LEFT SIDE

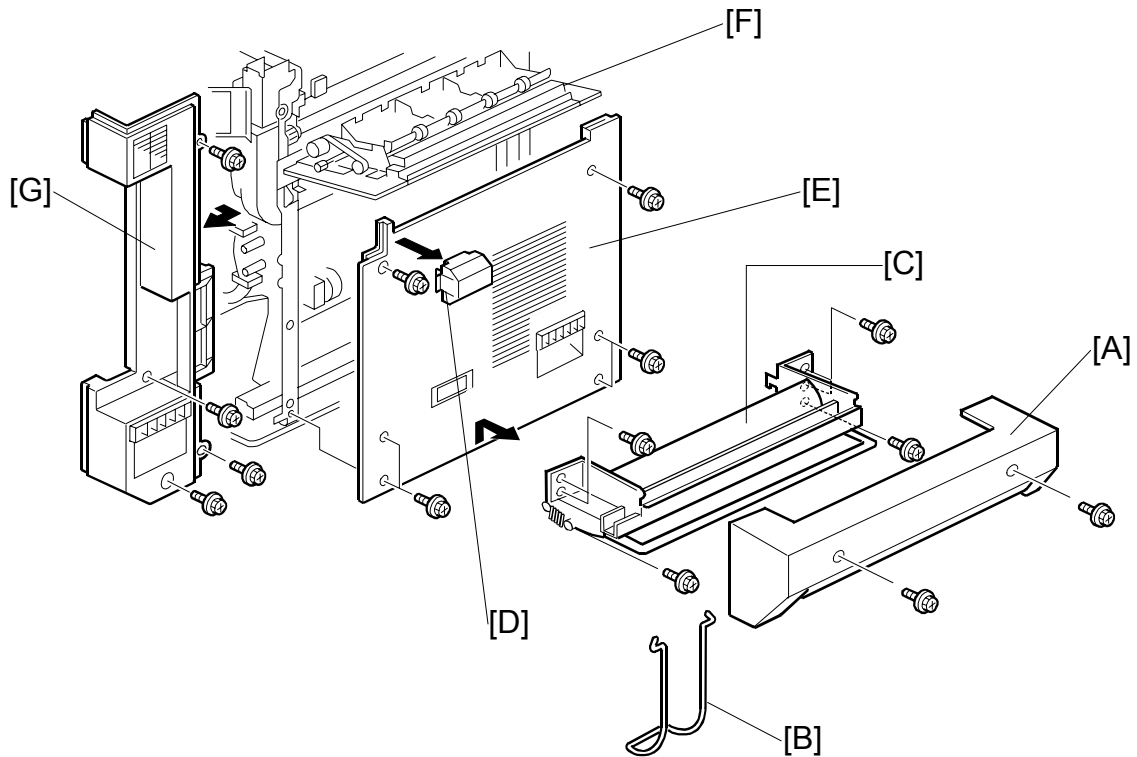

G130R517.WMFF

1. Duplex unit if the duplex inverter unit is installed. (☛ 3.3.2)
2. Duplex unit base cover [A] (🔩 x 2)
3. Duplex inverter guide [B] (Guide holder x 1)
4. Duplex unit base [C] (🔩 x 6)
5. Connector cover [D] if the duplex inverter unit is not installed.
6. Left cover [E] (🔩 x 6, 1 hook)
7. Rear cover (☛3.5.1)
8. Open the left door [F]
9. Rear left cover [G] (🔩 x 4)

3.5.6 UPPER LEFT COVER AND OPERATION PANEL

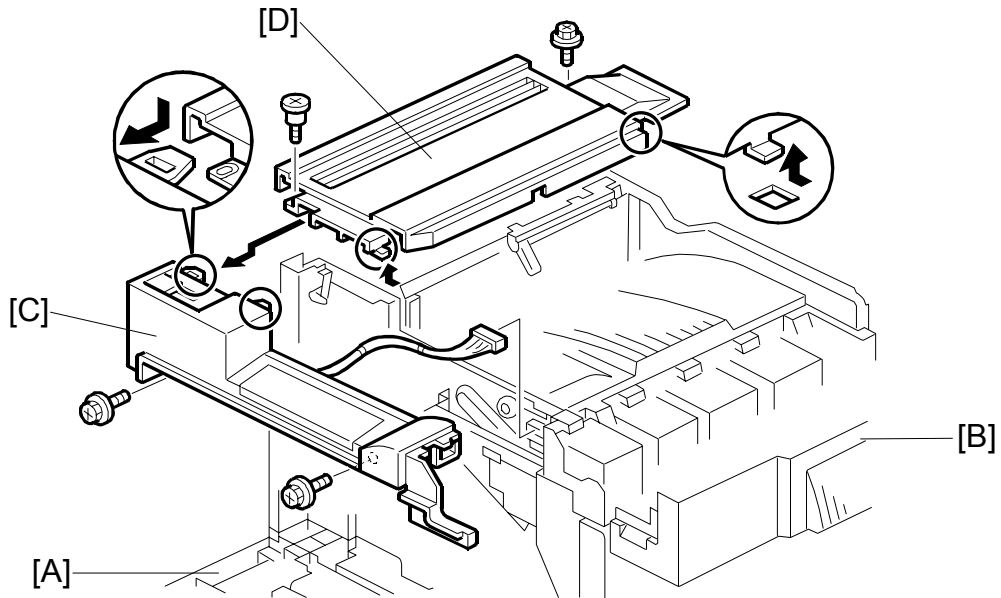

G130R909.WMFF

1. Open the front cover [A].
2. Open the upper right cover [B].
3. Upper rear cover (☛ 3.5.1)
4. Operation panel [C] (⚙ x 2, 📏 x 1, 2 hooks)
5. Upper left cover [D] (⚙ x 1, Shoulder-screw x 1, 2 hooks)

Replacement
Adjustment

3.6 LASER OPTICS

⚠ WARNING
Turn off the main switch and unplug the machine before you do the procedures in this section. Laser beams can cause serious eye injury.

3.6.1 CAUTION DECAL LOCATIONS

The caution decals locations are shown below.

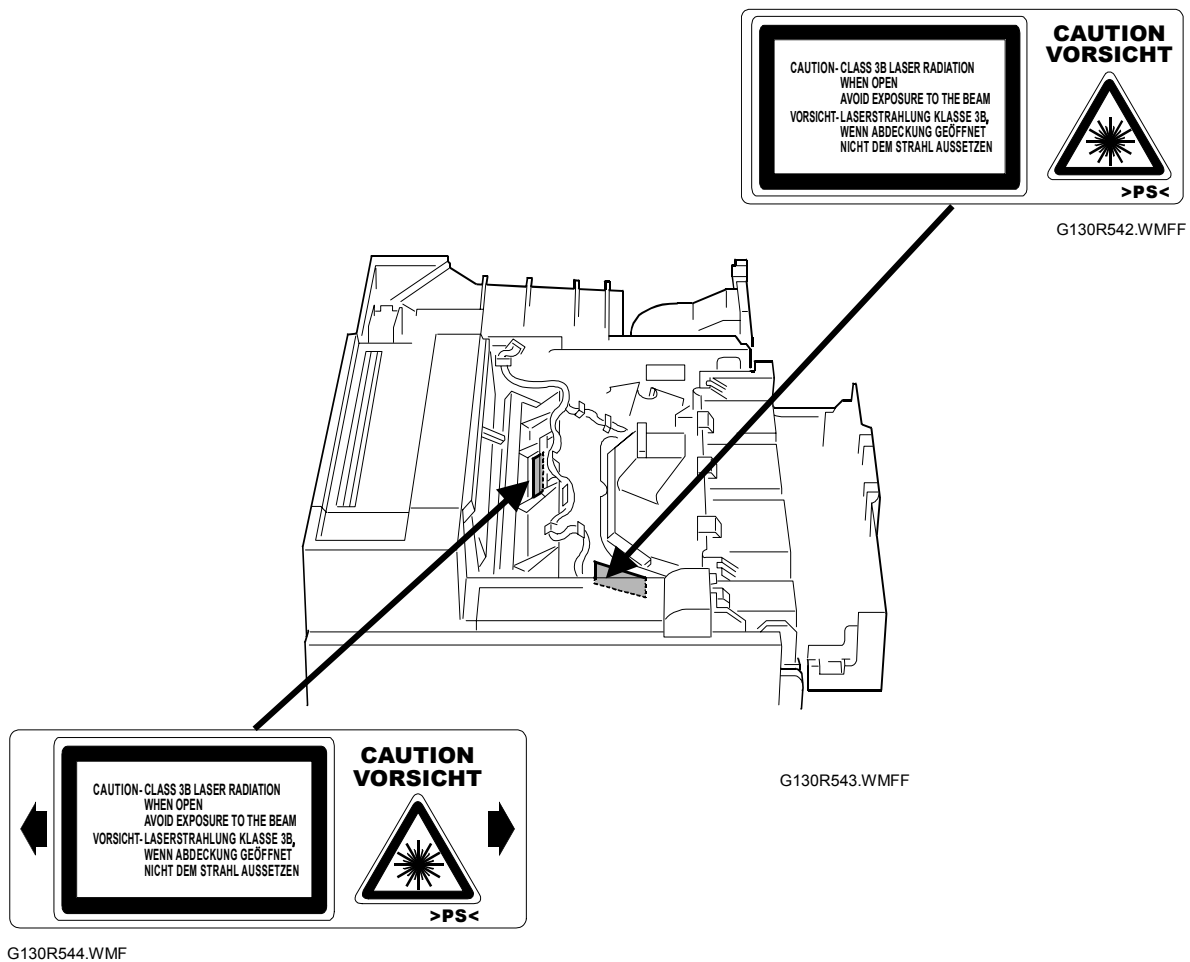

⚠ WARNING
Make sure you turn off the main switch and disconnect the power plug from the power outlet before you disassemble or adjust the laser unit. This machine uses a class IIIb laser beam with a wavelength of 655 nm and an output of 7 mW. The laser can cause serious eye injury.

3.6.2 LASER OPTICS HOUSING UNIT

CAUTION: Remove the sponge padding and the tag from the new unit before you install the new laser optics-housing unit.

Steps 1 through 4 show the procedure for a newly supplied unit that replaces the current one.

1. Top cover of the laser optics housing unit [A] (⚙ x 4)
2. Sponge padding [B]
3. Tag [C]
4. Reinstall the top cover.

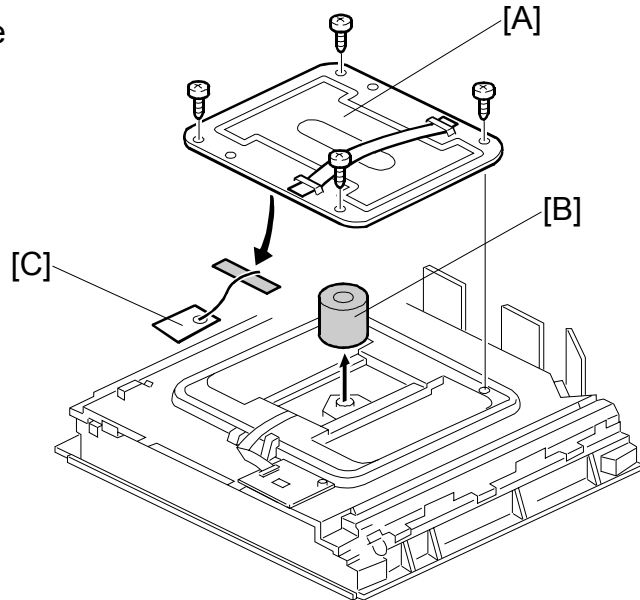

Replacement Adjustment

G130R545.WMFF

5. Rear cover, upper rear cover (➡ 3.5.1)
6. Right cover, upper right cover (➡ 3.5.3)
7. Paper exit tray [D] (⚙ x 2)

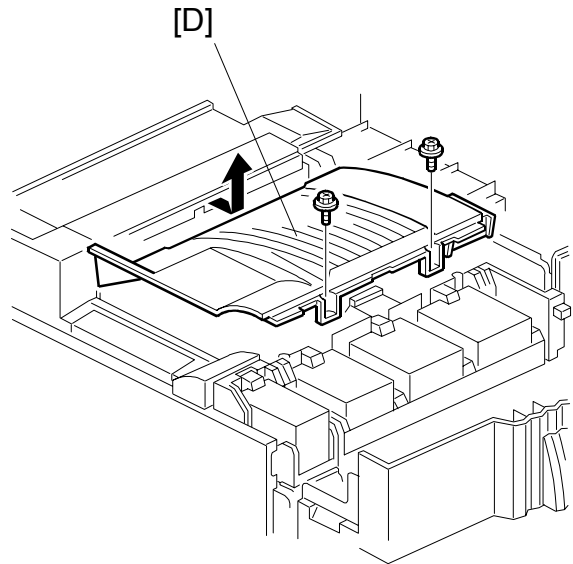

G130R904.WMFF

- 8. Securing screws for the toner supply unit [A] (⌘ x 4)
- 9. Securing screws for the laser optics housing unit [B] (⌘ x 2)

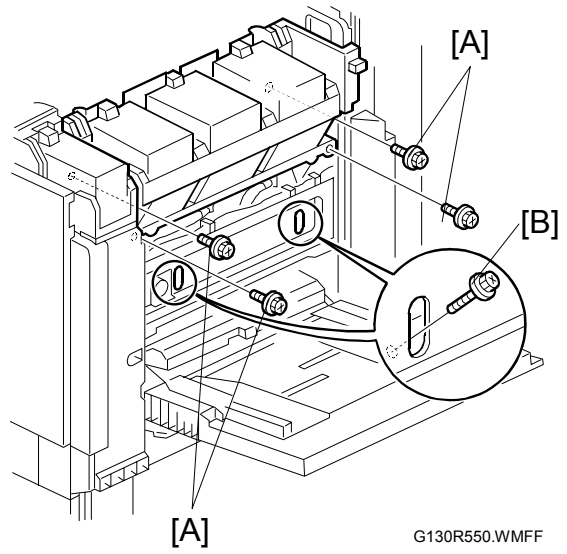

- 10. Hold the toner supply unit [C] up ①. Then lower it ②. The pins [D] on the front and rear shafts hold the unit.

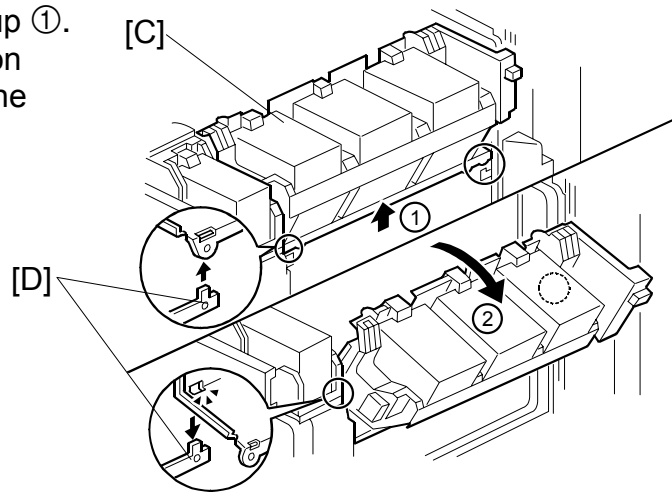

- 11. Connector cover [A] (🔩 x 1)
- 12. Three connectors [B] (🔌 x 3)

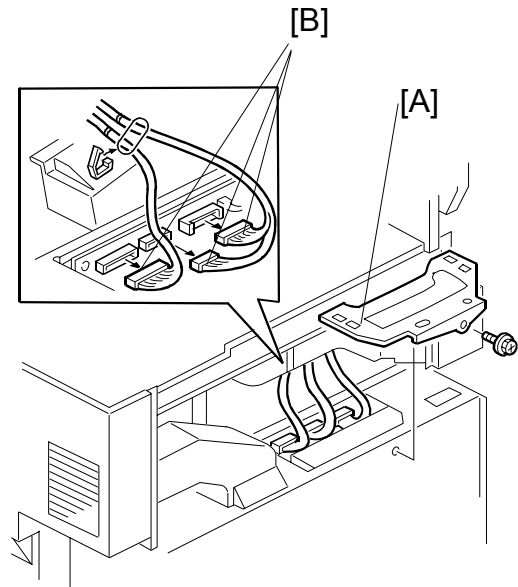

Replacement
Adjustment

G130R615.WMFF

- 13. Release the cable from the clamps [C] (🔧 x 5).

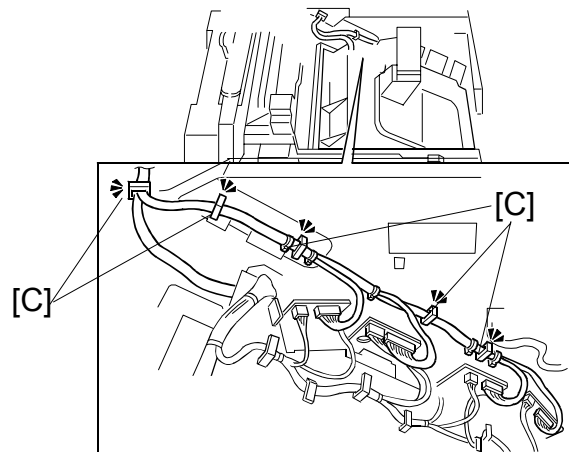

G130R554.WMFF

When reassembling the laser optics housing unit, follow the notes below.

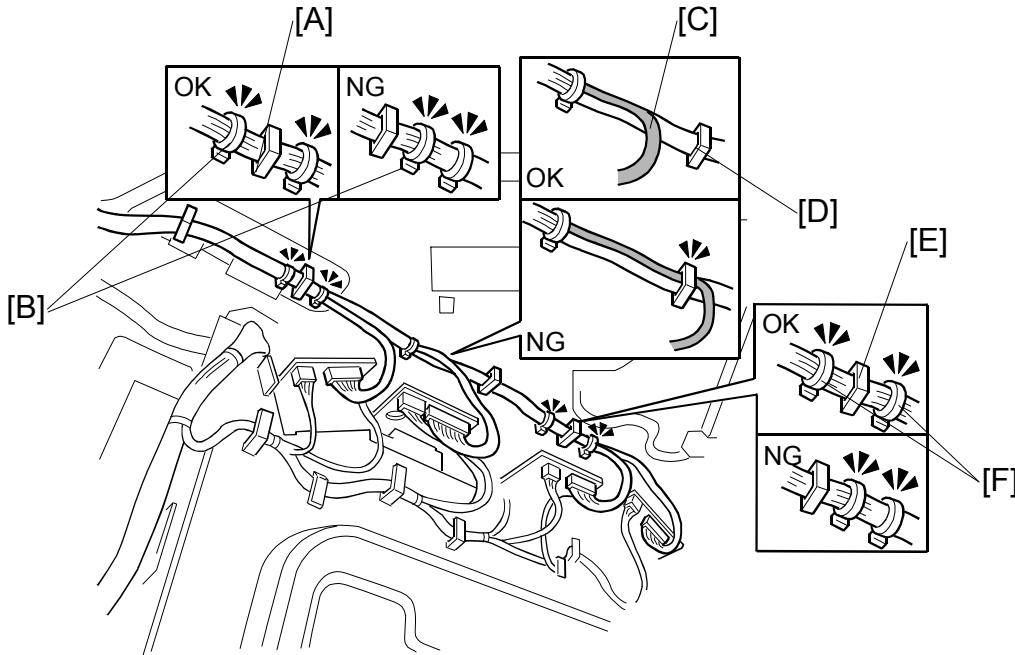

G130R555.WMFF

Make sure that the clamp [A] is positioned between two binds [B], the harness [C] is **not bound** by the clamp [D] and the clamp [E] is positioned between two binds [F].

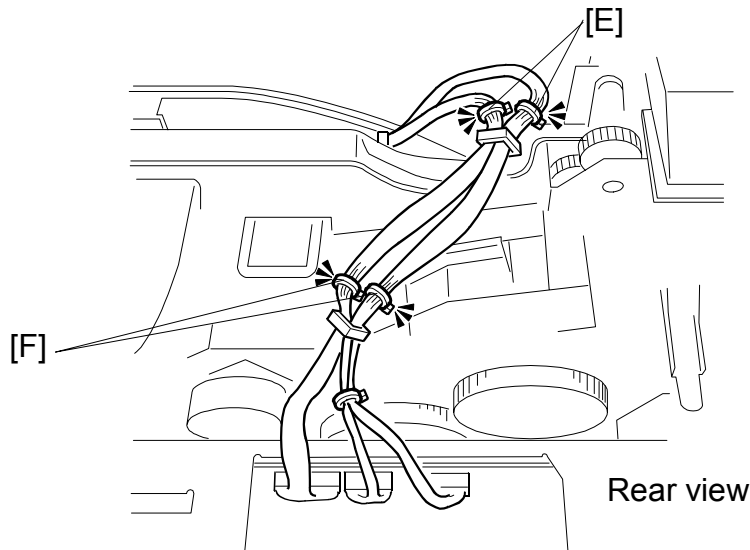

G130R556.WMFF

When you connect the harnesses from laser optics housing unit to the BCU, make sure that the binds [E] are positioned and the binds [F] are positioned as diagram shows.

Enter the SP mode and set "Disable" with SP2-920-1 after you replace the laser optics housing unit.

14. Duct [A]
15. Securing screws for the laser optics housing unit [B] (⌀ x 2)
16. Put a sheet of paper [C] between the laser optics housing unit and the machine rear frame.
NOTE: This does not let the cables be caught by the brackets when you lift the laser optics housing unit.
17. Hold the unit with both hands and slowly lift it up. Make sure that the cables from the laser diode board are not caught by the brackets when you do this.
NOTE: The cables can be caught by the brackets and the laser diode board may be damaged if you are not careful.
18. Do adjustments (☛ go to the procedures on the following page) after you reinstall the laser optics housing unit.

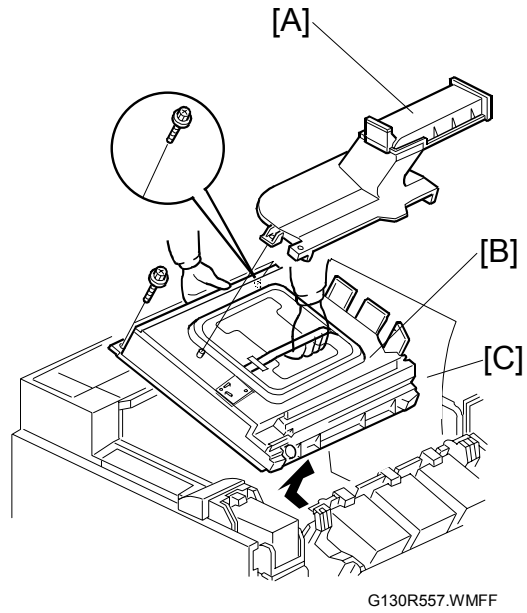

Replacement Adjustment

Do the forced line position adjustment (SP5-993-2 or Menu > Maintenance > Color Regist. > Auto Adjust) after you install the laser optics housing unit.

There are three decals on the laser optics housing unit as shown at right side. However, these decals are not used for this machine.

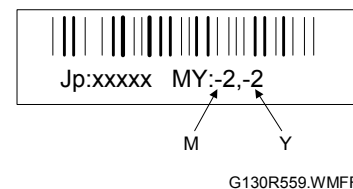
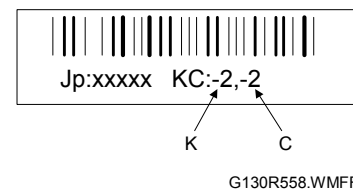
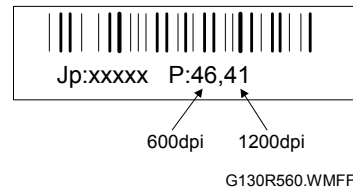

3.6.3 POLYGON MIRROR MOTOR

1. Laser optics housing unit
(☛ 3.6.2)
2. Top cover [A] (🔩 x 4)
3. Harness cable on the polygon-mirror-motor drive-board [B]
4. Twelve connectors on the four LD boards [C]

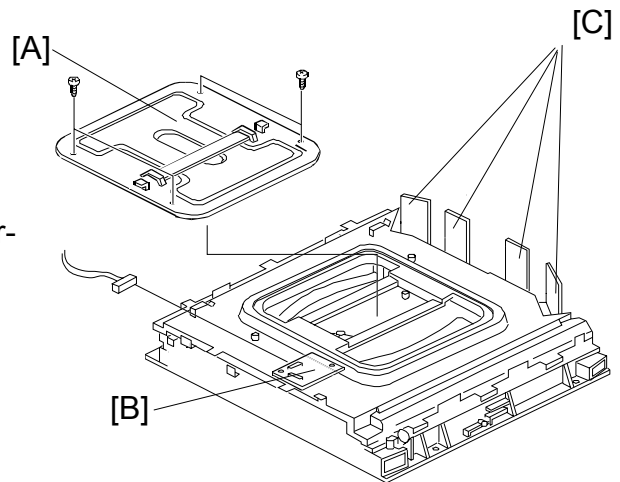

G130R562.WMFF

5. Upper cover [D] (🔩 x 11, 🔩 x 6)
NOTE: Two of the eleven connectors are on the reverse side of the upper cover.

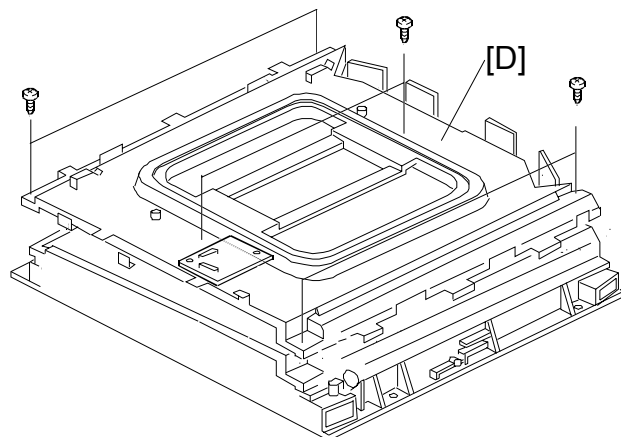

G130R563.WMFF

6. Air-current rectifier [E] (🔩 x 3)
7. Polygon mirror motor [F] (🔩 x 4, 📏 x 1)

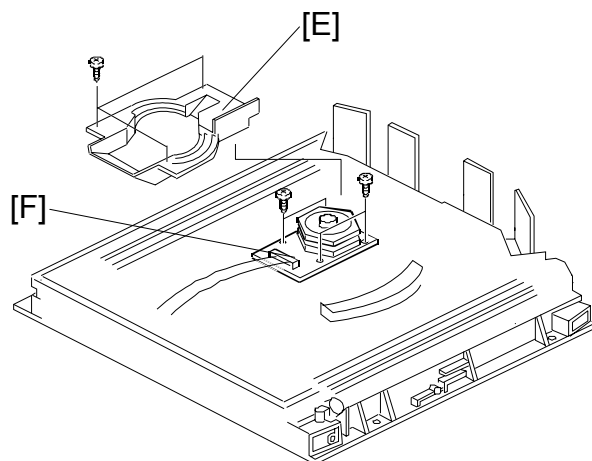

G130R564.WMFF

3.6.4 POLYGON MIRROR MOTOR DRIVE BOARD

1. Laser optics housing unit (☛ 3.6.2)
2. Polygon mirror motor drive board [A] (⚙️ x 2, 📏 x 2)

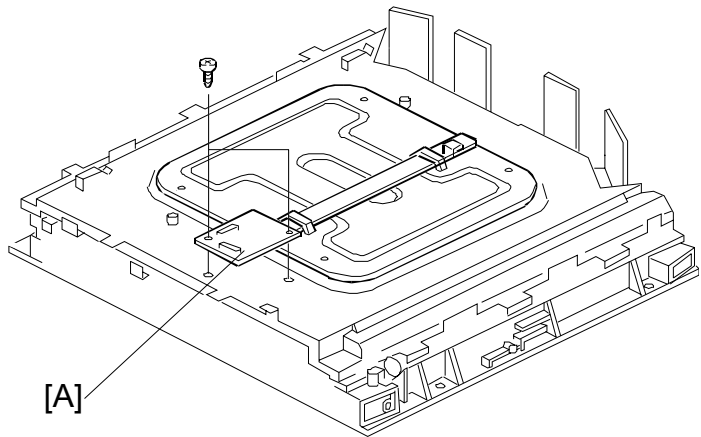

G130R565.WMFF

Replacement
Adjustment

3.6.5 LASER SYNCHRONIZING DETECTOR BOARDS

1. Laser optics housing unit (☛ 3.6.2)
2. Synchronizing detector boards [A] (📏 x 1 for each, ⚙️ x 1 for each)

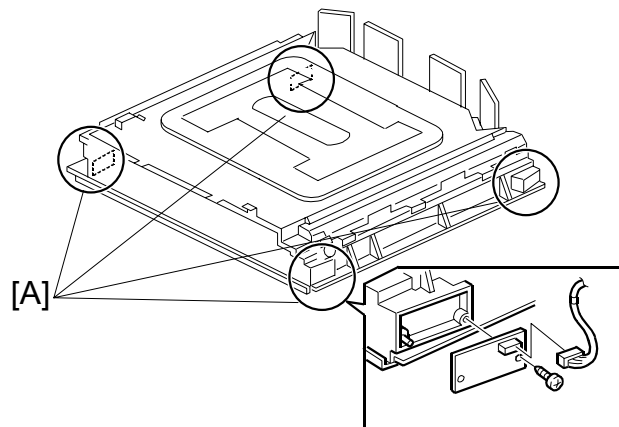

G130R566.WMFF

3.7 PCU AND DEVELOPMENT UNIT

NOTE: Do not touch the PCU drum. Do not let metal objects touch the development sleeve.

1. Turn the main switch off.
2. Open the front cover [A].
3. Loosen the 2 screws [B₁][B₂] (on the drum positioning plate).
NOTE: Fasten screw [B₁] first. Then fasten screw [B₂] when you reassemble.
4. Turn the release lever [C] counter-clockwise.
5. Lift the drum positioning plate.

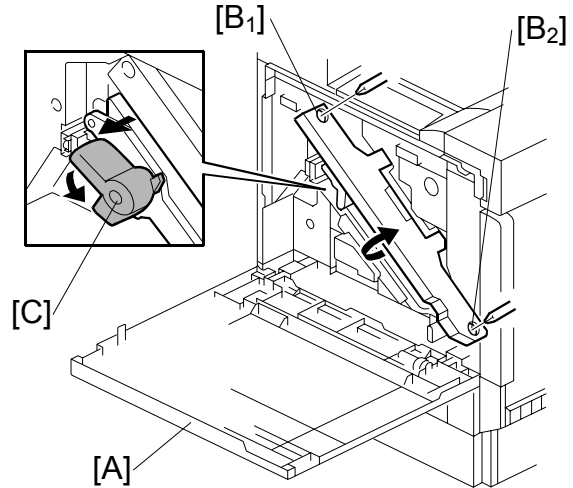

G130R567.WMFF

6. Pull the development unit [D] out.
7. Check that the development units are installed in the correct color order: (black → yellow → cyan → magenta from left to right).

NOTE: Keep the units level and shake them several times from side to side before you install the new development units.

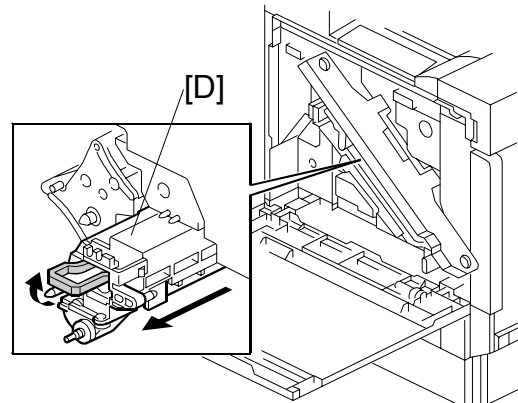

G130R568.WMFF

8. Release the lever and pull a PCU [E] out until you see the handle.
9. Grasp the handle [F]. Then pull the PCU out of the machine.
10. Turn the main switch on. The machine starts the initialization for the new unit.

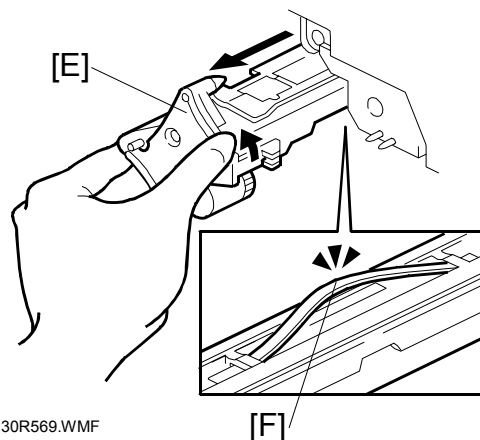

G130R569.WMF

3.8 PAPER FEED

3.8.1 PICK-UP, FEED, AND SEPARATION ROLLERS

Tray 1 and Tray 2

1. Tray 1 and Tray 2
2. Pick-up roller [A] (1 hook)
3. Feed roller [B] (⌀ x 1)
4. Separation roller [C] (⌀ x 1)

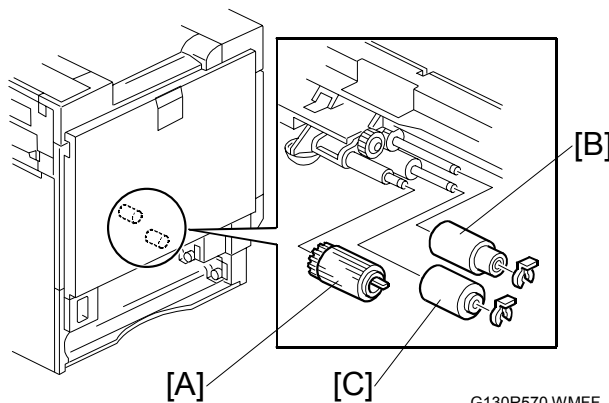

G130R570.WMFF

By-pass Tray

1. Open the right door.
2. By-pass tray cover [A] (1 hook, ⌀ x 1)
3. Raise the paper end sensor actuator [B].
4. Pick-up roller [C] (1 hook)

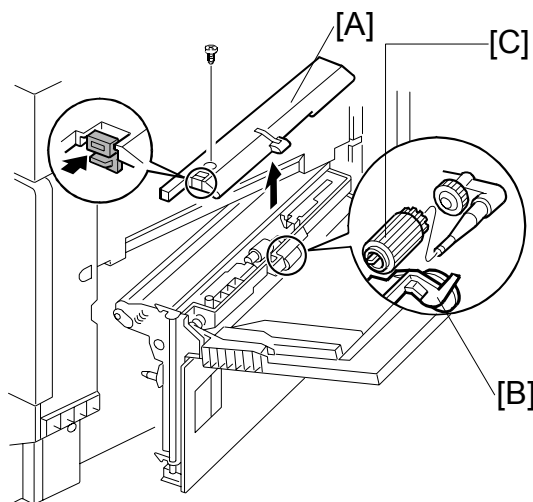

G130R571.WMFF

5. Feed roller [D] (⌀ x 1)
6. Vertical transport cover [E] (⌀ x 4)

NOTE: Remove the rear right cover (☛ 3.8.4). This lets you have easier access to the four screws.

7. Separation roller [F] (⌀ x 1)

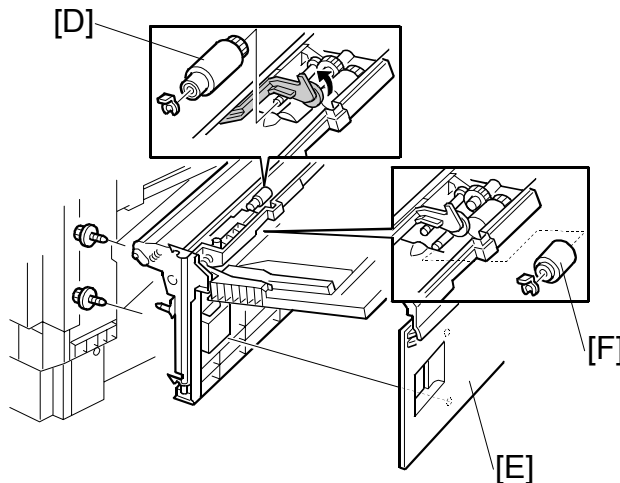

G130R572.WMFF

3.8.2 PAPER WIDTH DETECTION BOARD

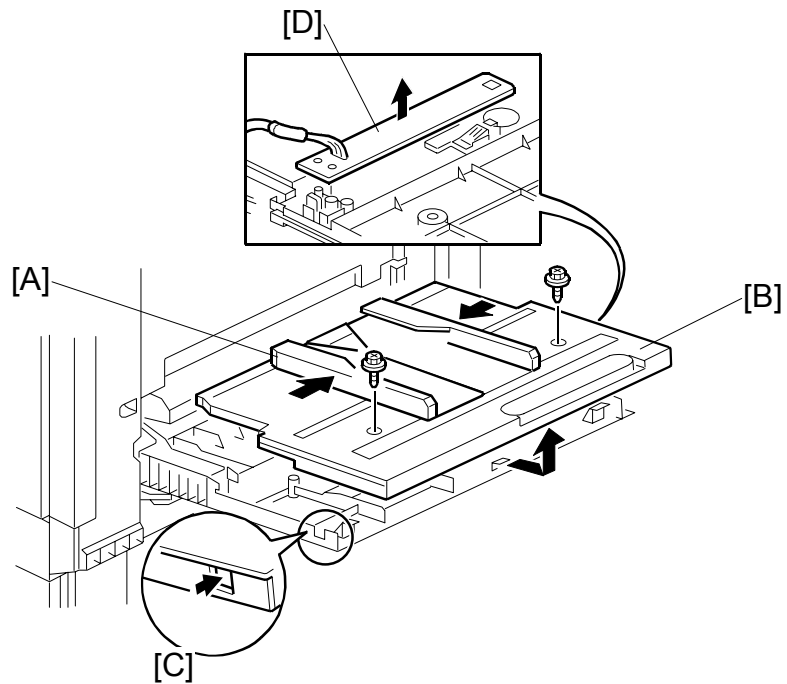

G130R573.WMFF

1. Open the by-pass tray.
2. Center the side fences [A].
3. By-pass tray cover [B] (⚙ x 2, 2 hooks)
4. Paper width detection board [D] (☑ x 1)

NOTE: There is a square opening [C] on each side. Push the hooks through these openings to release them.

NOTE: Open the bottom cover [E] to remove the connector.

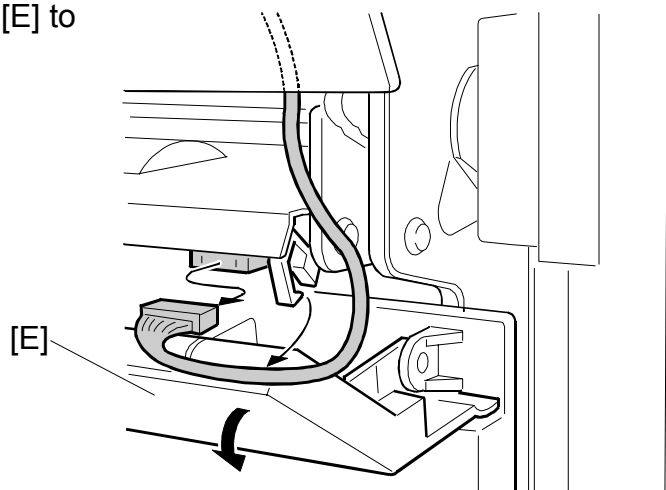

G130R574.WMFF

3.8.3 VERTICAL TRANSPORT SENSOR

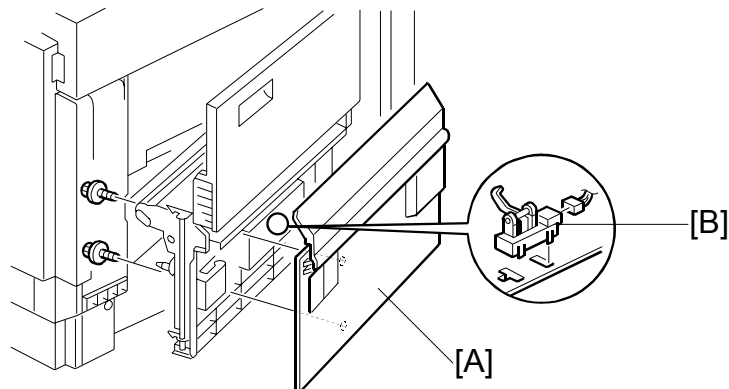

G130R575.WMFF

1. Open the right door.
2. Vertical transport cover [A] (⚙️ x 4)
NOTE: Remove the rear right cover (🔧 3.8.4). This lets you have easier access to the four screws.
3. Vertical transport sensor [B] (🔧 x 1)

 Replacement
Adjustment

3.8.4 RIGHT DOOR UNIT

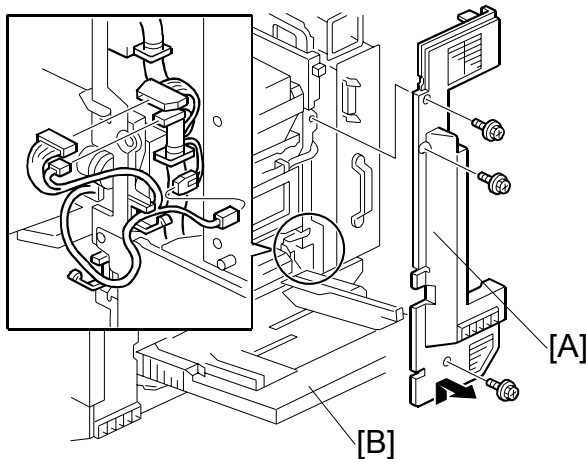

G130R576.WMFF

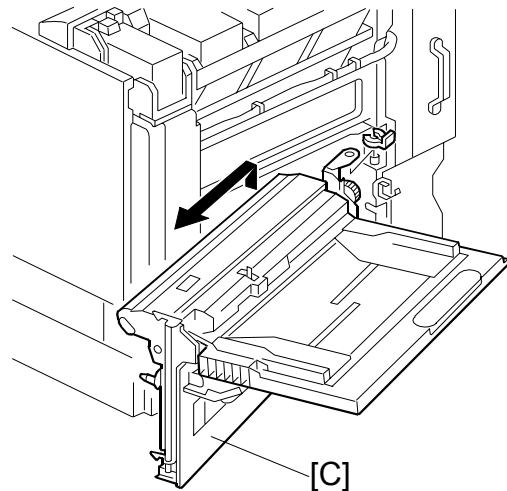

G130R577.WMFF

1. Rear cover, upper rear cover and upper right cover (🔧 3.5.1)
2. Rear right cover [A] (⚙️ x 4)
3. Open the right door [B].
4. Lift the vertical transport unit [C]. This removes it from its hinges (🔧 x 3, 🔄 x 1).

3.8.5 REGISTRATION SENSOR AND RELAY SENSORS

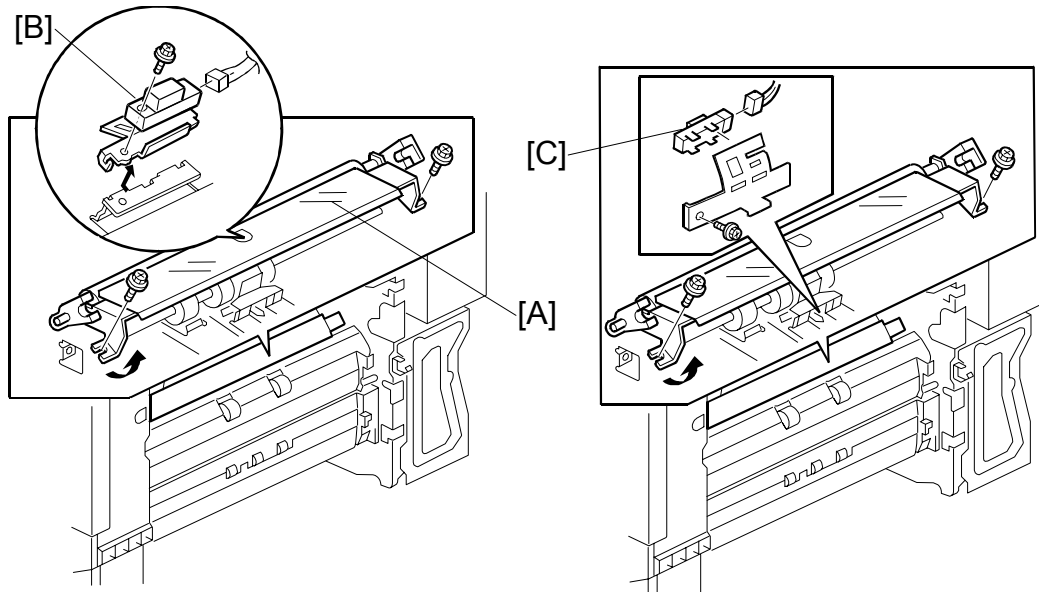

G130R578.WMFF

G130R579.WMFF

1. Right door unit (☛ 3.8.4)
2. Registration guide [A] (🔩 x 2)
3. Registration sensor [B] (🔩 x 1, 📏 x 1)
4. Relay sensor [C] (🔩 x 1, 📏 x 1)

3.8.6 PAPER FEED CLUTCHES

1. Paper trays
2. Rear cover (☛ 3.5.1)
3. Swing out the high voltage supply unit (☛ 3.12.2).
4. Clutch holder [A] (🔩 x 2, 1 bearing)
5. Paper feed clutch for tray 1 [B] (📏 x 1)
6. Clutch holder [C] (🔩 x 2, 1 bearing)
7. Paper feed clutch for tray 2 [D] (📏 x 1)

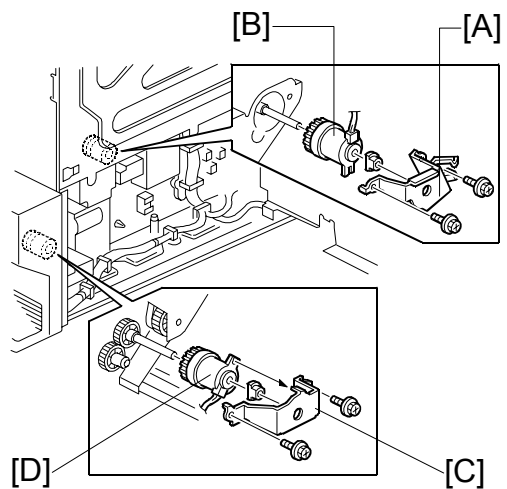

G130R580.WMFF

3.8.7 BY-PASS FEED CLUTCH

1. Right door unit (☛ 3.8.4)
2. By-pass tray cover [A]
(🔧 x 1, 1 hook)
3. Loosen the screw on the right door latch [B].
4. Turn the latch in the opposite direction.
5. Upper guide plate [C]
(🔧 x 4, 📏 x 1)
6. Support plate [D] (Ⓢ x 2)
7. Relay gear [E] (1 hook)
8. By-pass feed clutch [F] (📏 x 1)

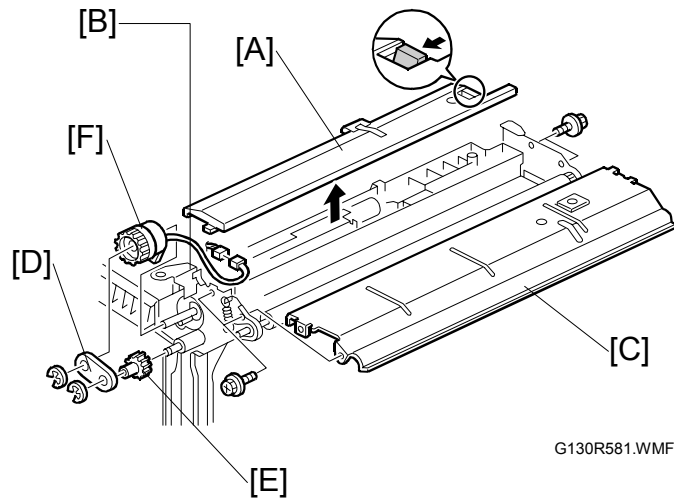

G130R581.WMFF

Replacement
Adjustment

3.8.8 TRAY LIFT MOTOR

1. Rear cover (☛ 3.5.1)
2. Swing out the high voltage supply unit
(☛ 3.12.2).
3. Sub power supply unit (☛ 3.12.7)
4. Tray lift motors (tray 1 [A], tray 2 [B])
(🔧 x 2, 📏 x 1)

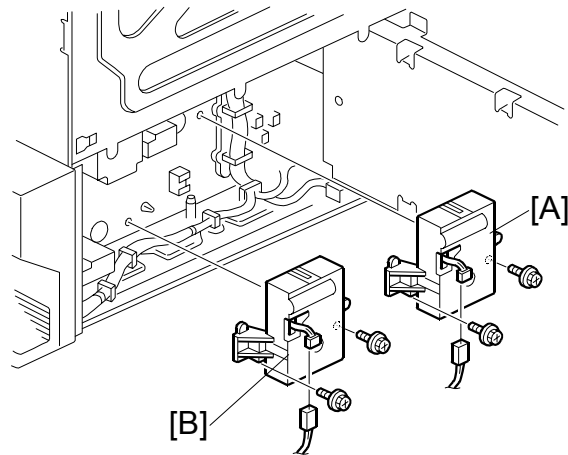

G130R583.WMFF

3.8.9 PAPER FEED MOTOR

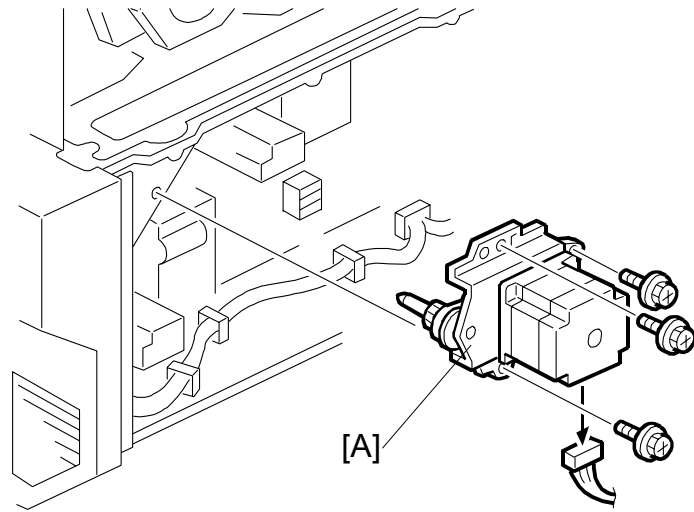

G130R584.WMFF

1. Rear cover (☛ 3.5.1)
2. Swing out the high voltage supply unit (☛ 3.12.2).
3. Paper feed motor [A] (☛ x 3, ☛ x 1)
NOTE: The connector is CN604 on the driver board.

3.9 TRANSFER AND PAPER TRANSPORT UNIT

3.9.1 TRANSFER UNIT

NOTE: Grasp the central areas of the front and rear frame when you remove or install the transfer unit.

NOTE: Do not touch the transfer belt [A]. Do not damage the entrance mylar [B].

Reset the maintenance counter, (SP7-804-17). Then do the output check, (SP5-804-66) after you replace the transfer unit.

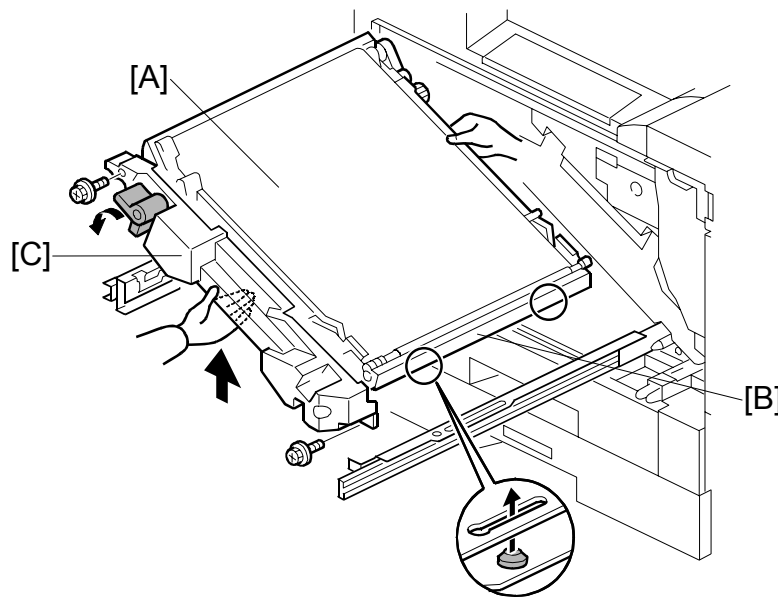

G130R585.WMFF

1. Duplex feed unit (☛ 3.4.1)
2. Turn the release lever counterclockwise. (☛ 3.7)
3. Pull out the transfer unit [C] until the whole unit shows (⚙ x 2).
4. Grasp the transfer unit grips as shown above. Lift the unit to remove it.

NOTE: Grasp the front grip. Use caution not to damage the actuator on the rear.

Do the following after you replace the transfer unit:

- Set the adjustment value in SP5-995-020 to "FbOn, DncOn".
- Execute SP5-993-031 and SP5-993-033. This SP mode measures the belt speed (middle and low) and stores the data.
- Execute SP5-995-027. This SP mode checks the belt regularity and stores the data.
- Execute SP5-995-025. This SP clears the speed control error counter.
- Turn the main power off and on after executing above SPs.
- Forced line position adjustment (SP5-993-002 or Menu > Maintenance > Color Regist. > Auto Adjust).
- Print the 1-dot grid (F) on A3/11" x 17" paper. Then check the color shift level (☛ 4.5.3).

3.9.2 TRANSFER BELT CLEANING UNIT

NOTE: Reset the maintenance counter, (SP7-804-18) after you replace the transfer belt-cleaning unit.

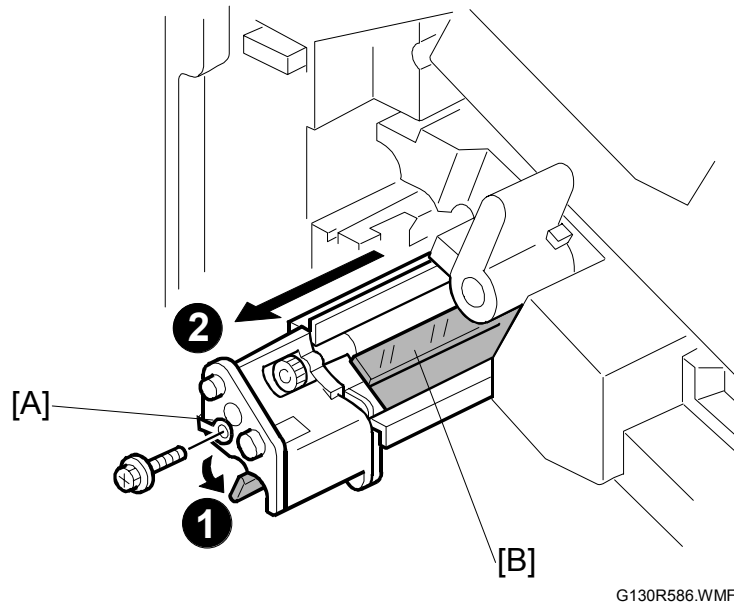

Pull out the transfer belt-cleaning unit [A] (1 x 1) at the same time you push the lever.

NOTE: 1) The blade [B] can damage the belt if you do not continue to push the lever.
2) Make sure that the transfer unit release lever is put back to the original position (3.7) when you reassemble.

Do a forced line position adjustment (SP5-993-002 or Menu > Maintenance > Color Regist. > Auto Adjust) after you replace the transfer belt-cleaning unit.

3.9.3 CLEANING BLADE AND CLEANING ROLLER

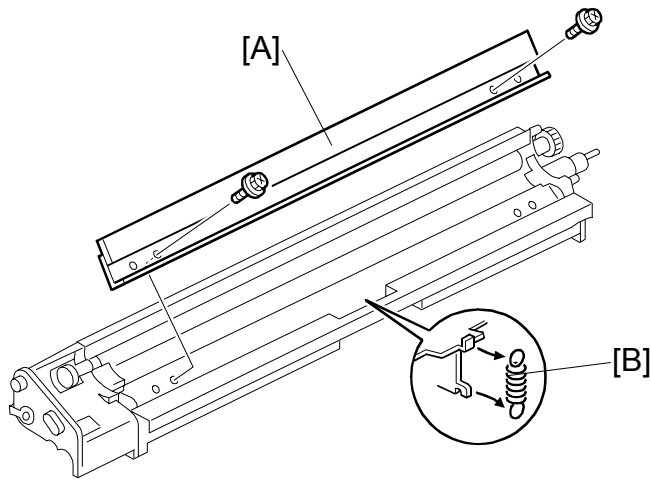

G130R587.WMFF

Replacement
Adjustment

1. Transfer belt cleaning unit (☛ 3.9.2)
2. Cleaning blade [A] (🔩 x 2)
3. Tension spring [B]

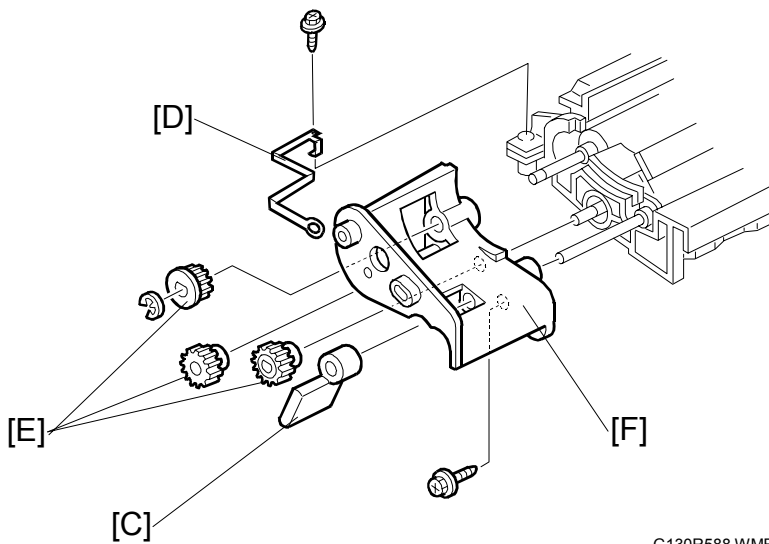

G130R588.WMFF

4. Lever [C]
5. Ground plate [D] (🔩 x 1)
6. 3 gears [E] (⊕ x 1)
7. Gear box [F] (🔩 x 1)

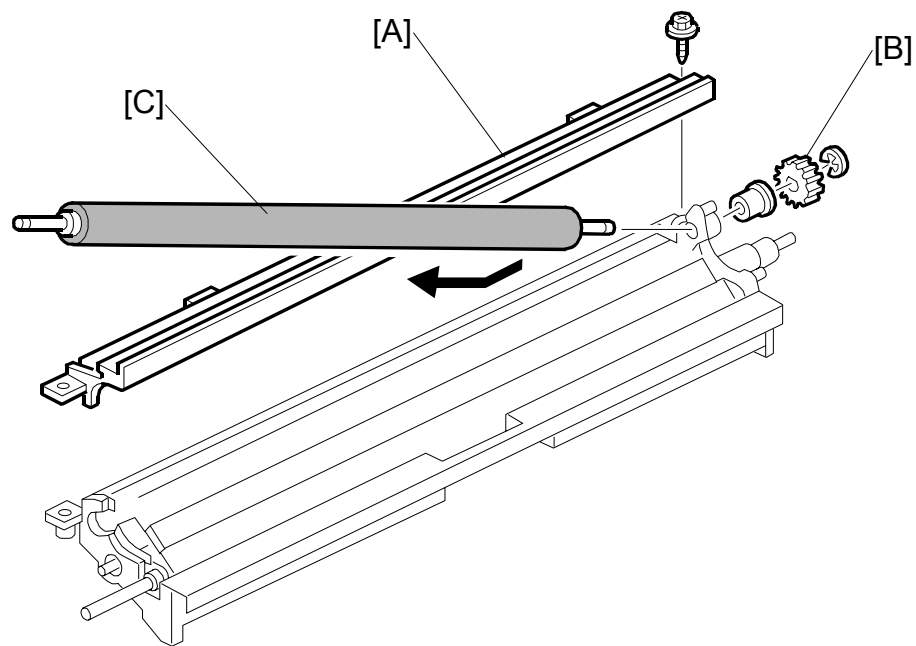

G130R589.WMFF

8. Roller cover [A] (⌀ x 1)
9. Cleaning brush gear [B] (Ⓒ x 1)
10. Cleaning brush [C] (Bushing x 1)

Do the forced line position adjustment (SP5-993-002 or Menu > Maintenance > Color Regist. > Auto Adjust) after you replace the cleaning blade.

3.9.4 TRANSFER BELT

NOTE: Do not touch the transfer belt. Hold the belt at its end position when you replace the belt.

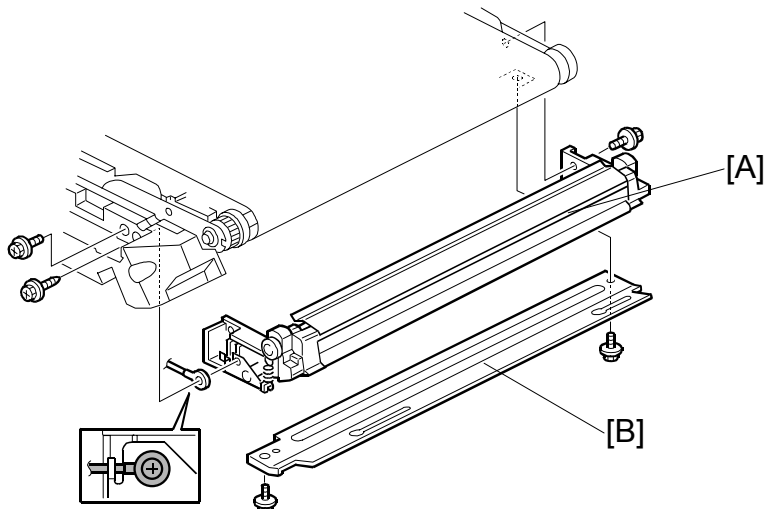

G130R590.WMFF

Replacement
Adjustment

1. Transfer belt cleaning unit (☛ 3.9.2)
2. Transfer unit (☛ 3.9.1)
3. Transfer entrance guide [A] (🔩 x 3)
4. Right bracket [B] (🔩 x 2)

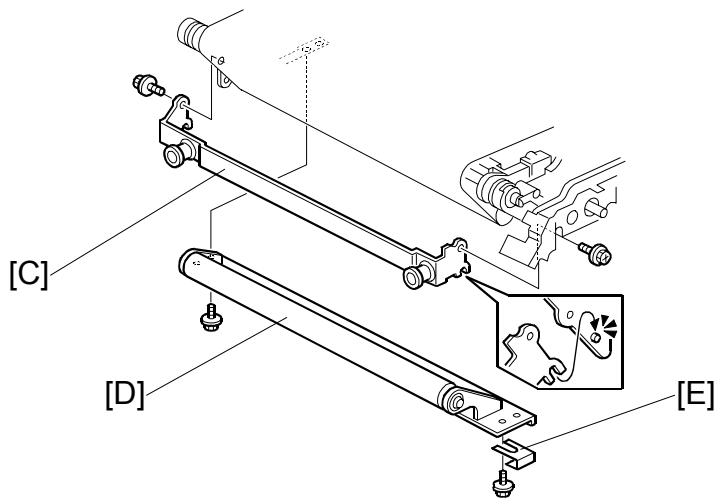

G130R591.WMFF

5. Left bracket [C] (🔩 x 2)
 6. Tension roller [D] (🔩 x 2, Spacer [E] x 1)
- NOTE:** Attach the spacer [E] to the original position when you reassemble.

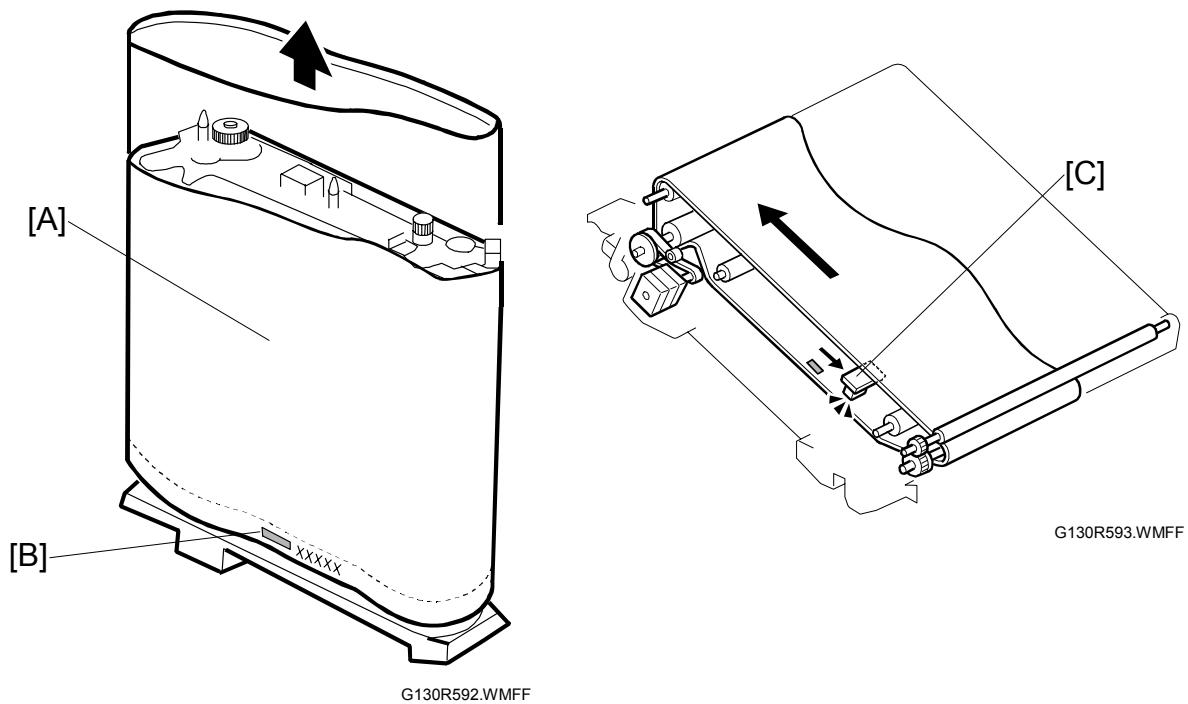

7. Lay the transfer unit on its side.
8. Grasp the upper end of the transfer belt. Then pull the transfer belt [A] up and out.
9. Clean the transfer belt mark sensor [C] with Blower brush.

NOTE: Clean the drive rollers with a damp cloth if they are dirty.

When you reinstall the transfer belt

The transfer belt must be installed with the mark “[B]” at the front side of the machine.

Do the same procedures mentioned in **3.9.1** after you replace the transfer belt.

3.9.5 TRANSFER UNIT DRIVE MOTOR

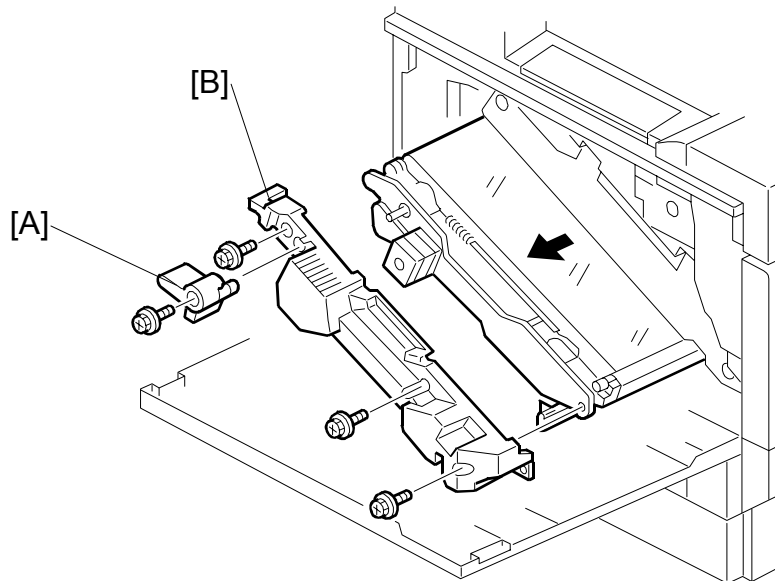

G130R594.WMFF

1. Transfer belt cleaning unit (☛ 3.9.2)
2. Pull out the transfer unit (☛ 3.9.1).
3. Release lever [A] (🔩 x 1)
4. Front cover [B] (🔩 x 3)

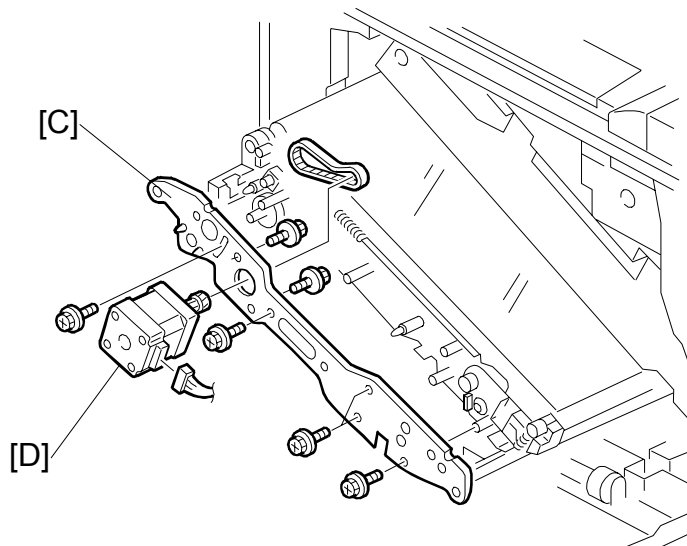

G130R595.WMFF

5. Front plate [C] (🔩 x 5, 🏹 x 1, Timing belt x 1, spring x 1)
6. Transfer unit drive motor [D] (🔩 x 2)

3.10 ID SENSORS

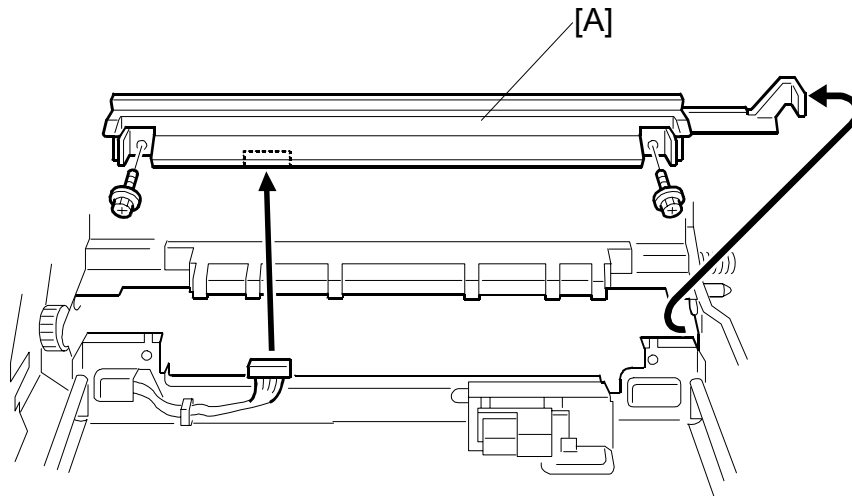

G130R596.WMFF

1. Transfer unit (☛ 3.9.1)
2. Fusing unit (☛ 3.11.1)
3. Black PCU (☛ 3.7)
4. ID sensor bracket [A] (🔩 x 2, 📏 x 1)

Make sure that the ID sensor bracket fits on the drum-positioning plate correctly when you reassemble.

3.11 FUSING

⚠ CAUTION

Be careful when you handle the fusing unit. It is very hot.

3.11.1 FUSING UNIT

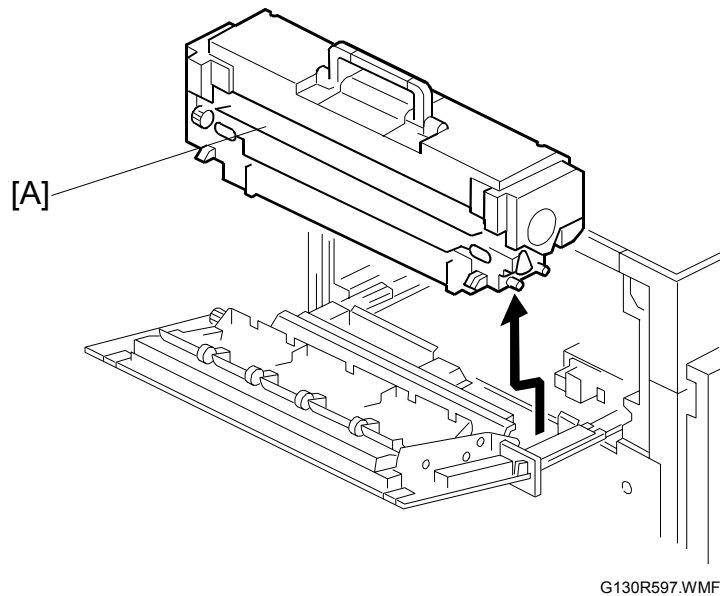

Replacement
Adjustment

1. Turn the main switch off.
2. Detach the finisher from the machine if it is installed.
3. Open the duplex inverter unit if it is installed.
4. Open the left door. Then pull it out.
5. Fusing unit [A]
6. Turn the main switch on. The machine starts initialization for the new unit.

If the customer uses thick paper, make some test prints on a sample of the paper used by the customer after you replace the fusing unit. Adjust the line speed for thick paper with the following SP if there are any color registration problems:

- SP1-004-007 (Development Motor Speed-[K] L Thick)

3.11.2 UPPER COVER

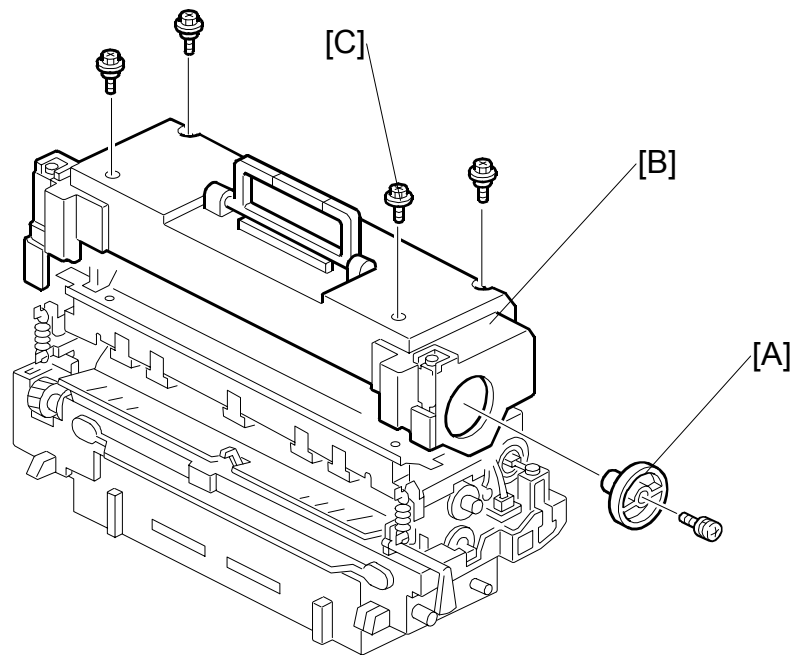

G130R598.WMFF

1. Detach the finisher from the printer if it is installed.
2. Open the duplex inverter unit if it is installed.
3. Fusing unit (☛ 3.11.1)
4. Knob [A] (☛ x 1)
5. Upper cover [B] (☛ x 4)

NOTE: One of the screws [C] is longer than the other screws. Make sure that the screw [C] is positioned as shown above when you reassemble this unit.

3.11.3 THERMOSTAT AND HEATING ROLLER THERMISTOR

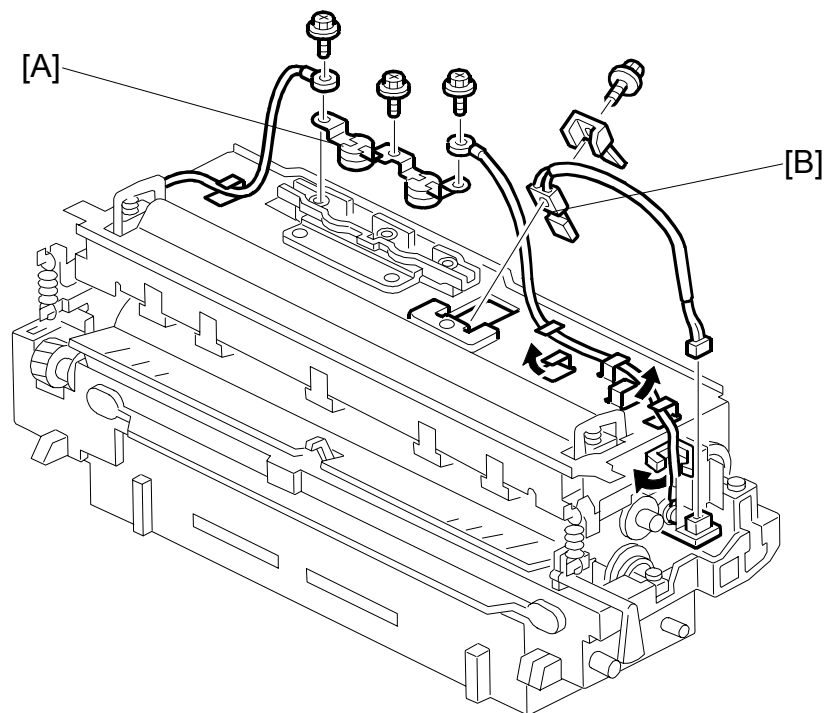

Replacement
Adjustment

G130R599.WMFF

1. Upper cover (☛ 3.11.2)
2. Thermostats [A] (🔩 x 3)
3. Heating roller thermistor [B] (🔩 x 1, 📐 x 1, bracket x 1)

3.11.4 PRESSURE ROLLER THERMISTOR AND FUSE

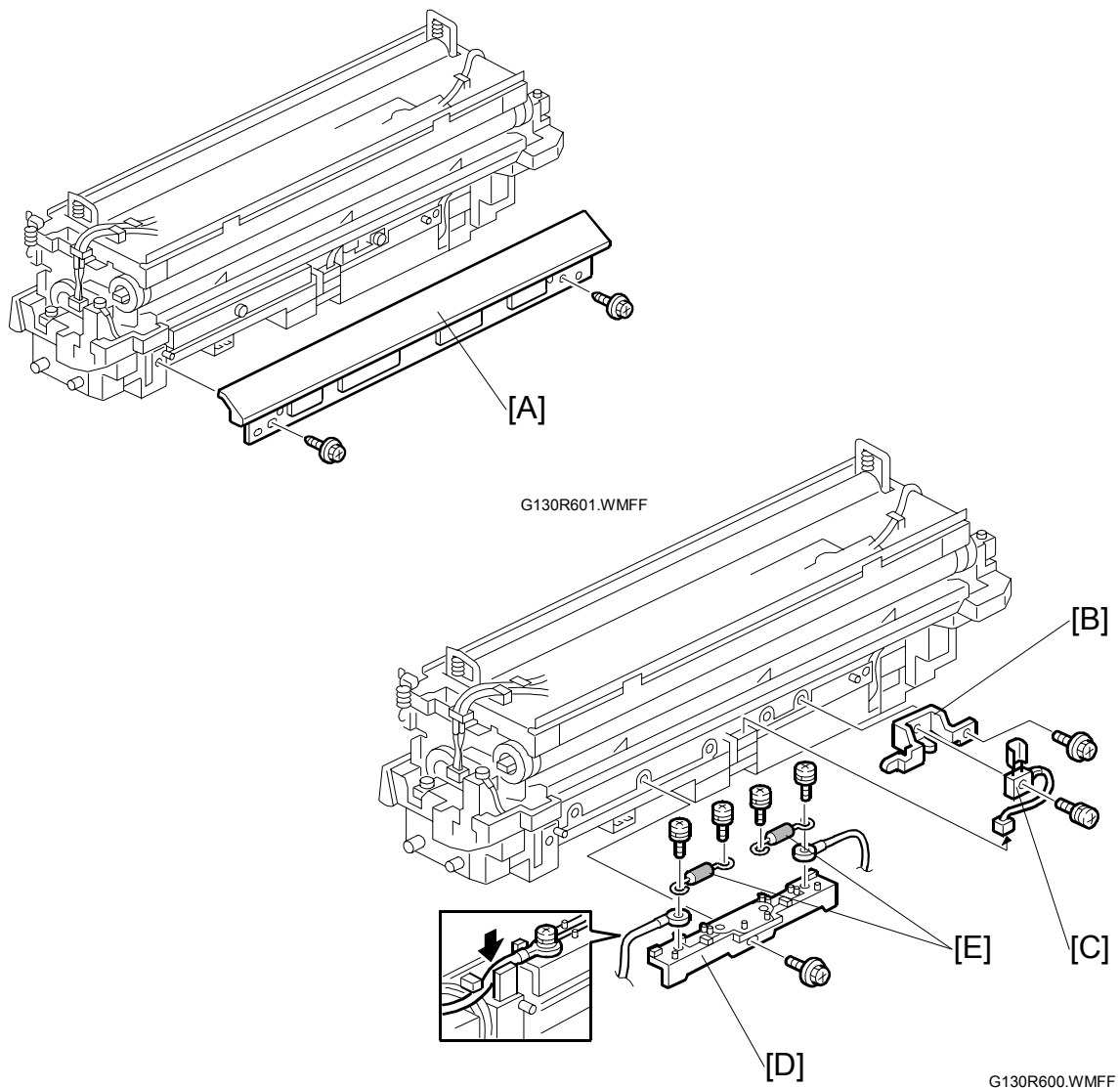

1. Lower right cover [A] (⚙️ x 2)
2. Pressure roller thermistor bracket [B] (⚙️ x 1, 📏 x 1)
3. Pressure roller thermistor [C] (⚙️ x 1)
4. Fuse assembly [D] (⚙️ x 1)
5. Fuses [E] (⚙️ x 2 each)

Reassembling

Make sure that the white parts of both fuses [E] face the front direction of the machine.

3.11.5 HEATING ROLLER LAMP AND PRESSURE ROLLER LAMP

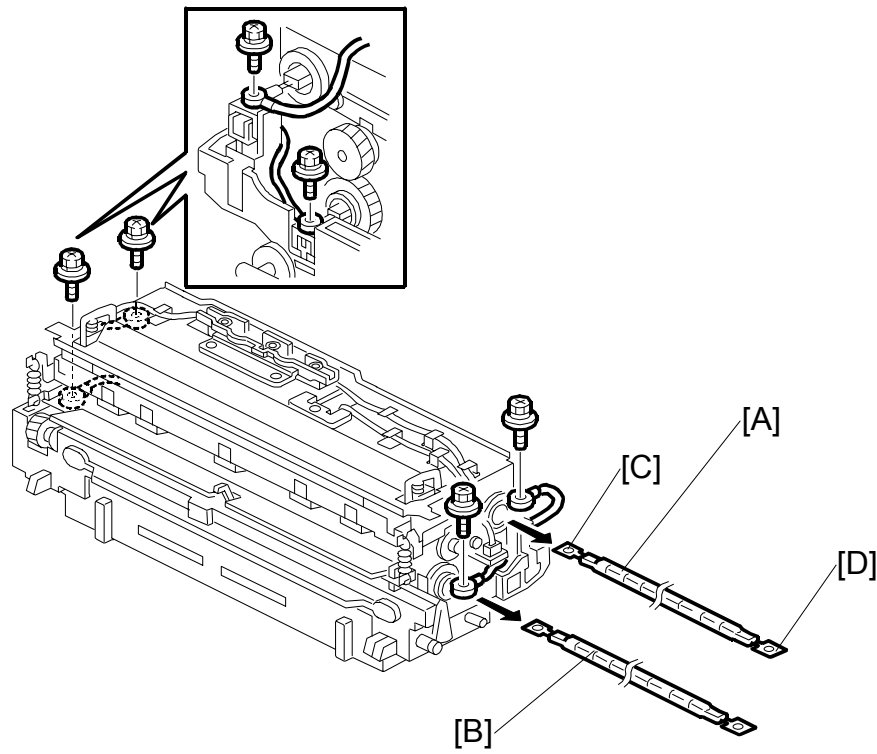

Replacement
Adjustment

G130R602.WMFF

1. Upper cover (➔ 3.11.2)
2. Heating roller lamp [A] (⚙ x 2, terminal bracket x 2)
NOTE: Make sure the front [C] and rear [D] ends of the lamp are on the correct terminals when you reinstall.
3. Pressure roller lamp [B] (⚙ x 2)

3.11.6 FUSING BELT UNIT

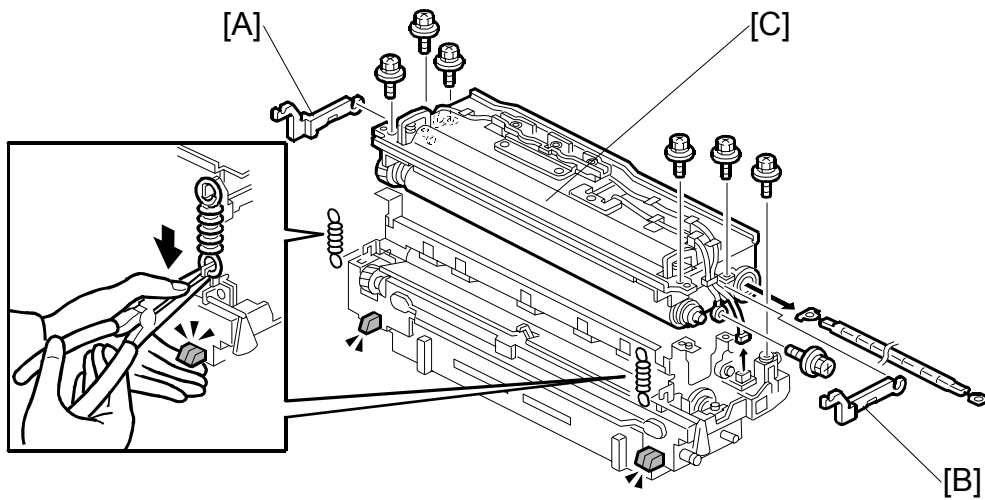

G130R603.WMF

1. Upper cover (☛ 3.11.2)
2. Heating roller lamp (☛ 3.11.5)
3. Pressure brackets [A] [B] (spring x 1 each)
NOTE: Use caution when you remove or attach the springs. The springs have strong tension and require more force than usual to remove them.
4. Fusing upper unit [C] (⚙ x 5, ⚙ x 1)

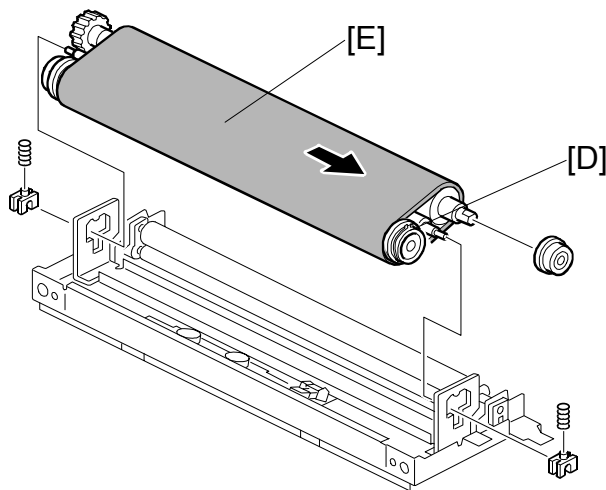

G130R604.WMFF

5. Tension roller [D] (spring x 2, roller holder x 2)
6. Fusing belt unit [E]

3.11.7 HOT ROLLER AND HEATING ROLLER

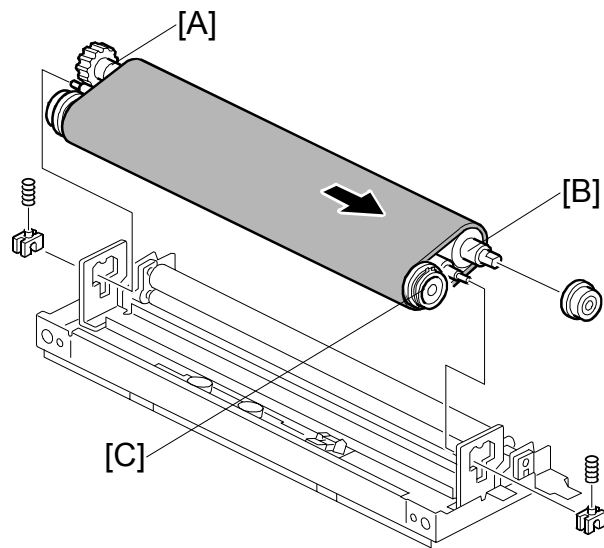

G130R605.WMFF

Replacement
Adjustment

1. Upper cover (☛ 3.11.2)
2. Heating roller lamp (☛ 3.11.5)
3. Fusing belt unit (☛ 3.11.6)
4. Hot roller gear [A] (☞ x 1)
5. Hot roller [B]
6. Heating roller [C]

Reassembling

Do the following procedures when you reassemble this unit:

- Apply grease to the roller shaft bearing of the pressure roller frame.
- Make sure that the edges of the bushings are positioned inside the shaft bearings.

3.11.8 UPPER PAPER GUIDE PLATE AND STRIPPER PAWLS

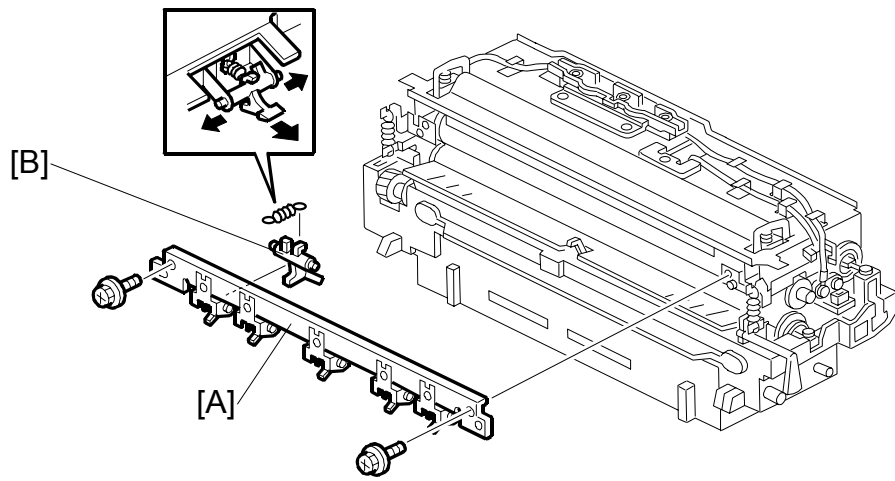

G130R606.WMFF

1. Upper cover (☛ 3.11.2)
2. Upper paper guide plate [A] (☛ x 2)
3. Stripper pawls [B] (spring x 1 each)

3.11.9 LOWER PAPER GUIDE PLATE AND STRIPPER PAWLS

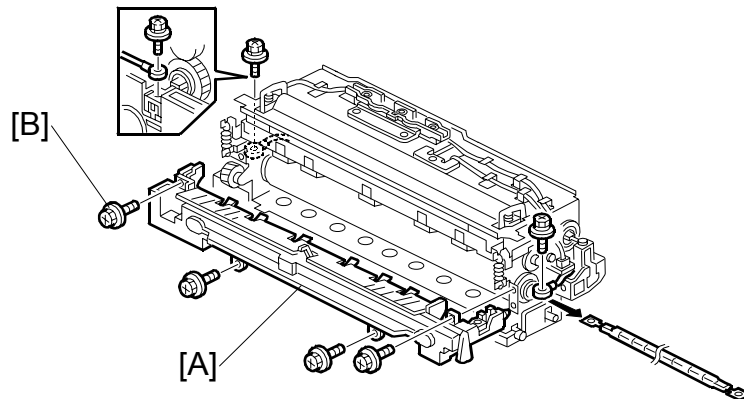

G130R607.WMFF

1. Upper cover (☛ 3.11.2)
2. Pressure roller lamp (☛ 3.11.5)
3. Lower paper guide unit [A] (☛ x 4)
NOTE: The screw [B] is different from the others. Make sure that the screw [B] is positioned as shown above.

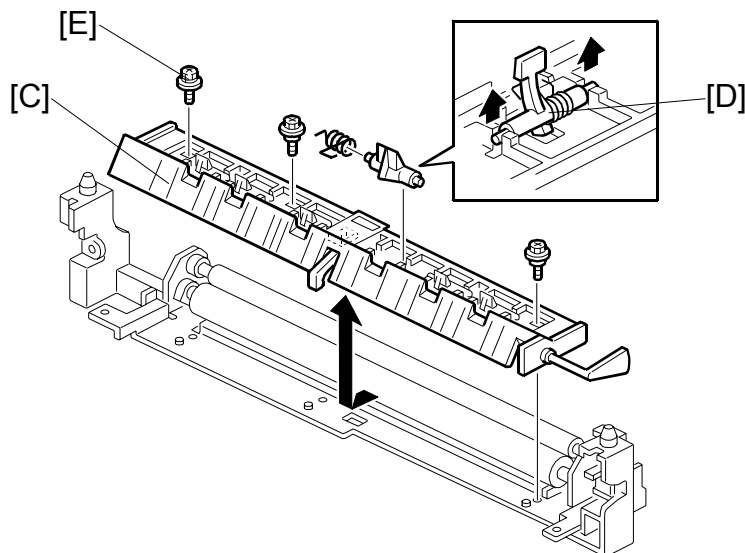

G130R608.WMFF

4. Lower paper guide plate [C] (☛ x 3)
5. Stripper pawls [D] (spring x 1 each)
NOTE: The screw [E] is different from the others. Make sure that the screw is positioned as shown above.

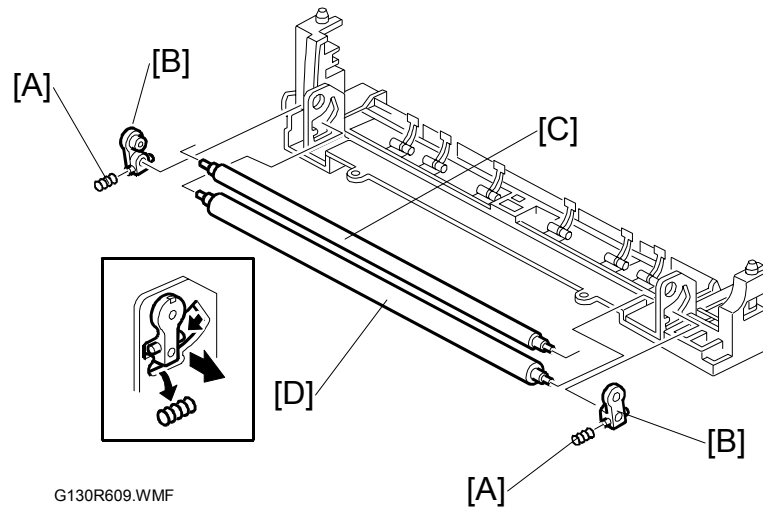
3.11.10 CLEANING ROLLER AND OIL SUPPLY ROLLER

G130R609.WMF

1. Upper cover (☛ 3.11.2)
2. Pressure roller lamp (☛ 3.11.5)
3. Lower paper guide unit (☛ 3.11.9)
4. Remove the springs [A].
5. Slide off the roller holder [B].
6. Cleaning roller [C] and oil supply roller [D]

3.11.11 PRESSURE ROLLER

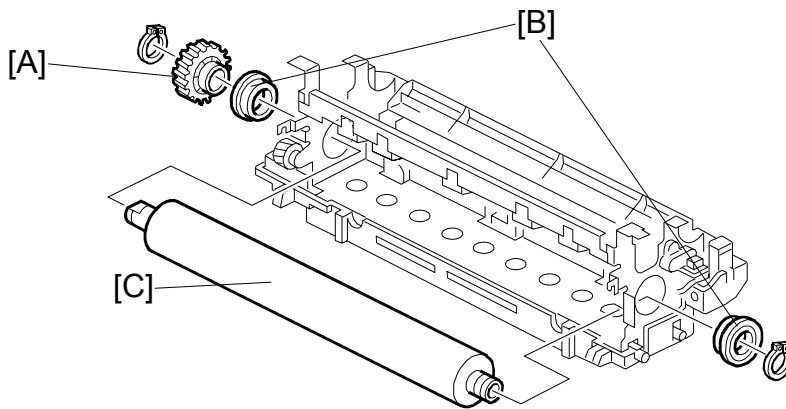

G130R610.WMFF

Replacement
Adjustment

1. Upper cover (☛ 3.11.2)
2. Heating roller lamp and pressure roller lamp (☛ 3.11.5)
3. Fusing upper unit (☛ 3.11.6)
4. Lower paper guide unit (☛ 3.11.9)
5. Pressure roller gear [A] and bushings [B] (C-ring x 2)
6. Pressure roller [C]

Reassembling

Apply grease to both ends of the pressure roller shaft when you reassemble this unit.

3.11.12 DRIVE GEAR

1. Fusing unit (☛ 3.11.1)
2. Gear hold bracket [A] (☛ x 1)
3. Drive gear [B] (☛ x 1)

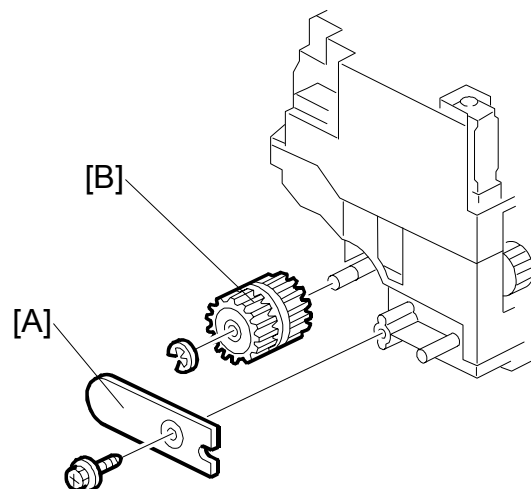

G130R611.WMFF

3.11.13 FUSING UNIT FAN

⚠ CAUTION
Make sure that the fan faces to the correct direction when you reinstall it. The arrow on the fan [D] and the arrow on the duct [D] must face to the same direction.

1. Rear cover and upper rear cover (☛ 3.5.1)
2. Left cover, rear left cover (☛ 3.5.5)
3. Connector cover (on the top of the controller box) (☛ 3.12.1)
4. Fusing fan duct [A] (🔩 x 2, 📏 x 1)

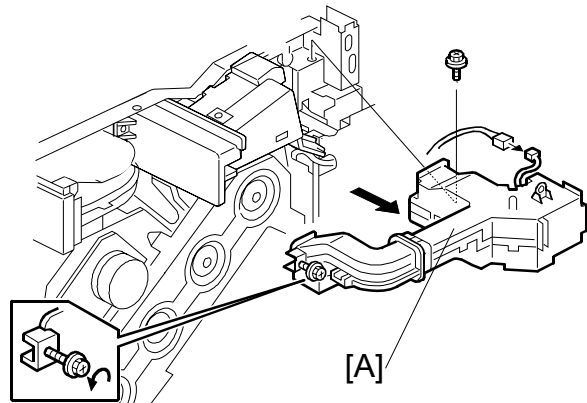

G130R612.WMFF

5. Release the hooks. Then remove the upper cover [B].
6. Fusing fan [C]

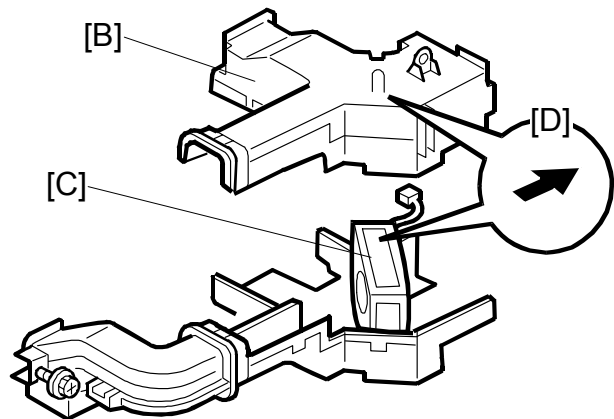

G130R613.WMFF

3.11.14 PAPER EXIT

1. Upper rear cover (☛ 3.5.1)
2. Upper left cover (☛ 3.5.6)
3. Exit upper limit sensor cover [A]
(☛ x 2)
4. Exit upper limit sensor [B]
5. Paper exit sensor [C]

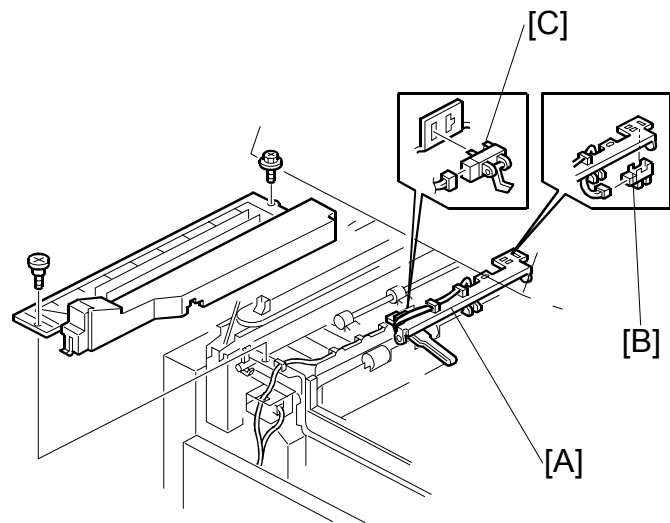

G130R614.WMFF

Replacement
Adjustment

3.12 ELECTRICAL COMPONENTS

3.12.1 MOVING THE CONTROLLER BOX OUT OF THE WAY

1. Rear cover (☛ 3.5.1)
2. Connector cover [A] (☛ x 1)
3. Three cables [B]

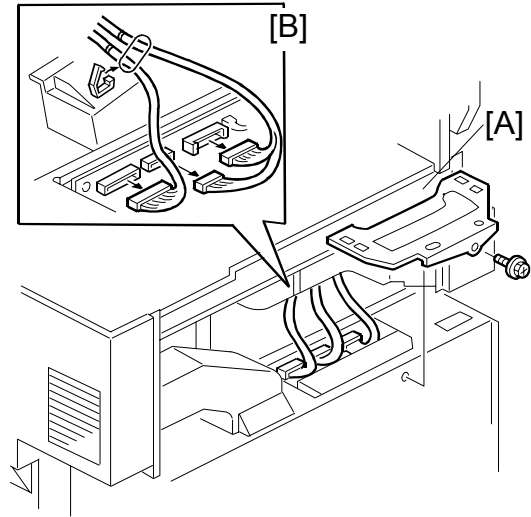

G130R615.WMFF

4. Swing out the controller box [C] (☛ x 4).

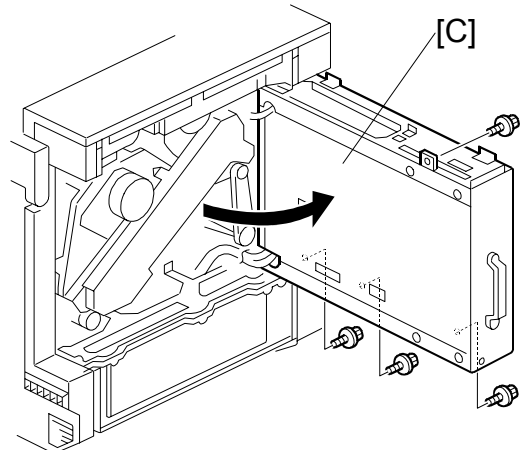

G130R616.WMFF

3.12.2 MOVING THE HIGH VOLTAGE SUPPLY UNIT - C, B OUT OF THE WAY

1. Rear cover (☛ 3.5.1)
2. Swing out the high voltage supply unit [A] (☛ x 2).

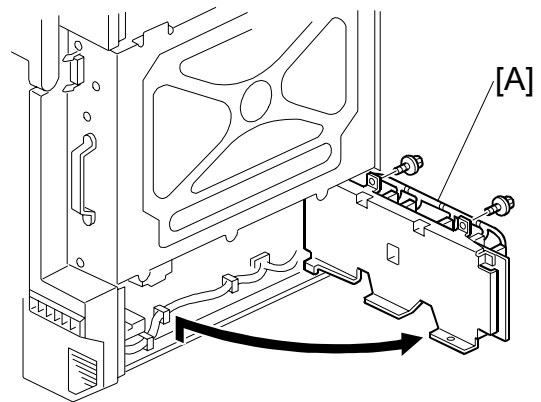

G130R617.WMFF

 Replacement
Adjustment

3.12.3 CONTROLLER AND BCU

- NOTE:** 1) Print out the SMC reports (“SP Mode Data” and “Logging Data”) before you replace the BCU or controller.
- 2) Remove the NVRAM on the old board. Then install it on the new board after you replace the BCU or controller.

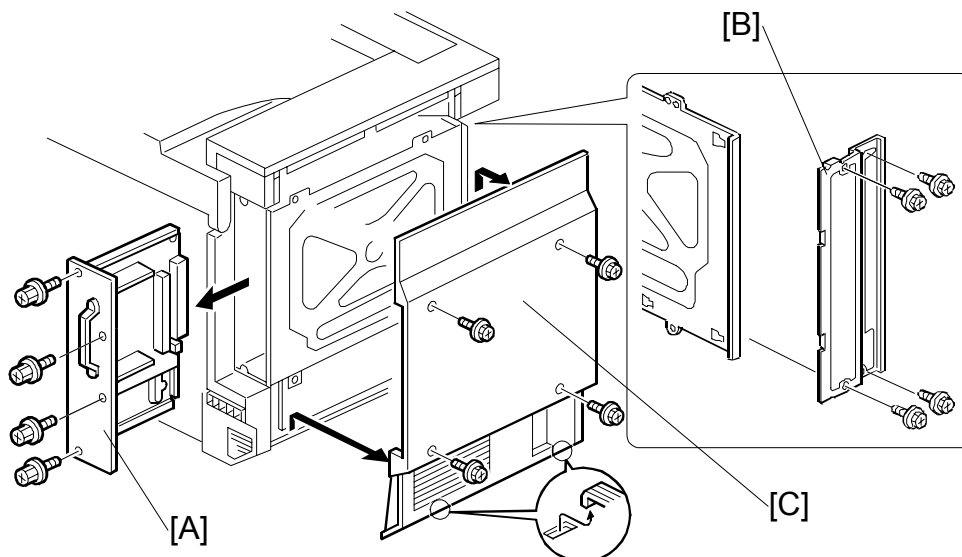

G130R618.WMFF

1. Controller [A] (☛ x 4)
2. Option bracket [B] (☛ x 4)
3. Rear cover [C] (☛ x 4)

4. Connector cover (☛ 3.12.1)

5. Cover bracket [A] (☛ x 5)

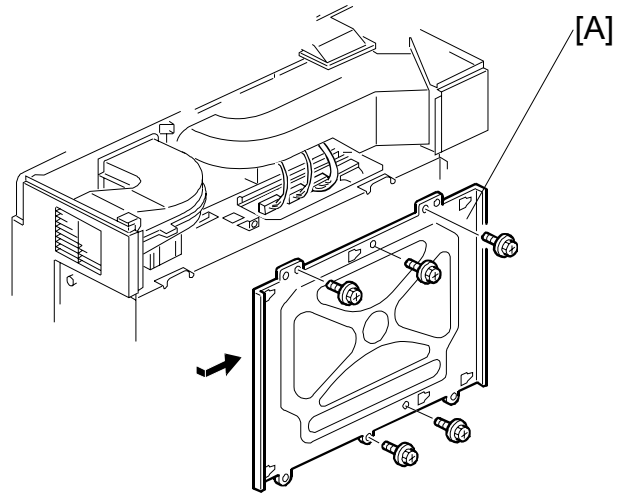

G130R619.WMFF

6. BCU [B] (All ☛'s, ☛ x 8)

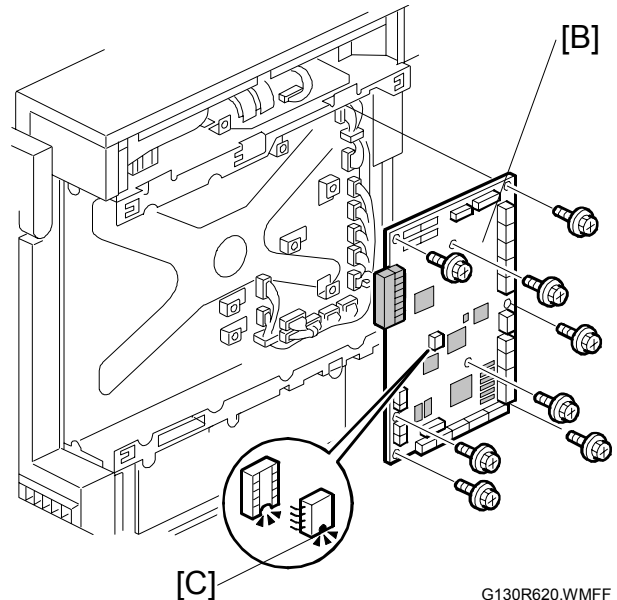

G130R620.WMFF

- CAUTION:** 1) Keep NVRAMs away from any objects that can cause static electricity. Static electricity can damage NVRAM data.
 2) Make sure the NVRAM is correctly installed on the board. Attach the NVRAM with the "half-disk" [C] heading down to the NVRAM slot.
 3) Make sure that the DIP-switch settings on the old board are the same for the new board (☛ 5.8) when you replace the BCU.

- NOTE:** 1) Make sure you print out the SMC reports ("SP Mode Data" and "Logging Data") before you replace the NVRAM.
 2) Remove the NVRAM on the old board. Then install it on the new board after you replace the BCU or controller. Replace the NVRAM (☛ 3.12.5) if the NVRAM on the old board is defective.

3.12.4 HDD

1. Controller (☛ 3.12.3)
2. HDD unit [A] (☛ x 2, Shoulder-screw x 3)

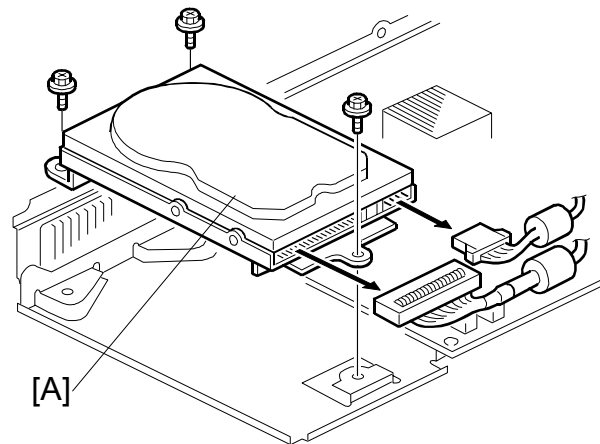

G130R621.WMFF

Replacement
Adjustment

3.12.5 NVRAM REPLACEMENT PROCEDURE

NVRAM on the BCU

1. Make sure that you have the SMC report (factory settings). This report comes with the machine.
2. Output the SMC data (☛ SP5-990-001) if possible.
3. Turn the main switch off.
4. Install an SD card into SD card slot 3. Then turn the main power on.
5. Copy the NVRAM data to an SD card (☛ SP5-824-001) if possible.
6. Turn off the main switch. Then unplug the power cord.
7. Replace the NVRAM on the BCU and reassemble the machine.
8. Plug in the power cord. Then turn the main switch on.
9. Select a paper-size type (☛ SP5-131-001).
10. Specify the device number of the machine.

NOTE: 1) Contact your supervisor for details on how to enter the device number.
2) SC195 or SC995 can be shown until the device number is correctly programmed.

11. Turn the main switch off and on.
12. Copy the data from the SD card to the NVRAM (☛ SP5-825-001) if you have successfully copied them to the SD card.
13. Turn the main switch off. Then remove the SD card from SD card slot 3.
14. Turn the main switch on.
15. Reset the settings for meter charge (☛ SP5-930-001 and -003 to -005).
16. Specify the SP and UP mode settings.
17. Do the process control self-check.

NVRAM on the Controller

1. Make sure that you have the SMC report (factory settings). This report comes with the machine.
2. Output the SMC data (☛ SP5-990-001) if possible.
3. Turn the main switch off. Then put a blank formatted SD card into SD card slot 3.
4. Turn the main switch on.
5. Copy the NVRAM data (☛ SP5-824-001) to an SD card if possible.
NOTE: You cannot do this procedure if the SD card is write-protected.
6. Enter SP mode. Then print out the SMC reports (☛ SP5-990-001) if possible.
7. Turn off the main switch. Then unplug the power cord.
8. Replace the NVRAM on the controller. Then reassemble the machine.
9. Plug in the power cord. Then turn the main switch on.
10. Copy the data from the SD card to the NVRAM (☛ SP5-825-001) if you have successfully copied them to the SD card.
NOTE: 1) The counter data in the user code information clears even if step 11 is done correctly.
2) An error message shows if the download is incomplete. However, you can still use the part of the address book data that has already been downloaded in step 11.
3) An error message shows when the download data does not exist in the SD card, or, if it is already deleted.
11. Go out of SP mode. Then turn the main switch off. Then remove the SD card from SD card slot 3.
12. Turn the main switch on.
13. Reset the settings for meter charge (☛ SP5-045, SP5-104 and SP5-812-001 and -002) if the meter charge (SP5-930-001) has been enabled.
14. Specify the SP and UP mode settings.

3.12.6 REMOVING THE HIGH VOLTAGE SUPPLY BOARD - C, B

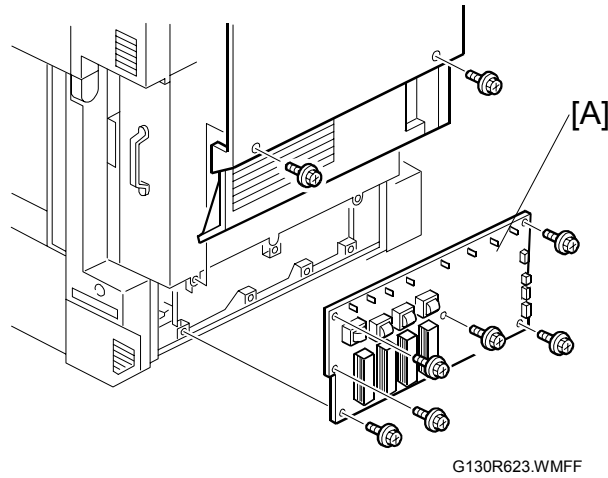

1. Rear cover (☛ 3.5.1)
2. High voltage supply board [A] (All ⚙'s, 🔩 x 6)

3.12.7 SUB POWER SUPPLY UNIT

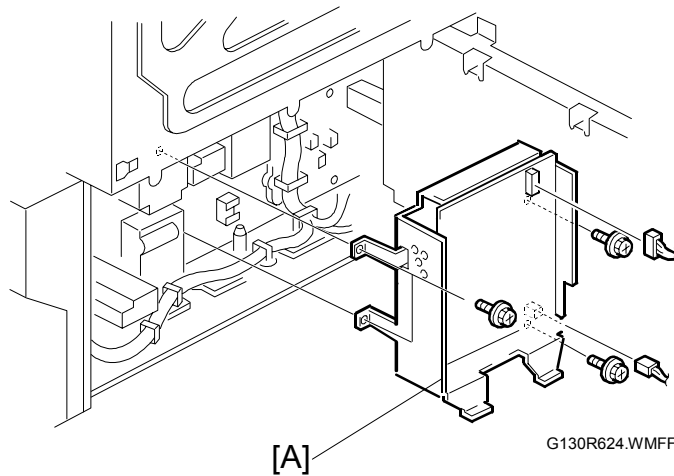

1. Rear cover (☛ 3.5.1)
2. Swing out the high voltage supply unit (☛ 3.12.2)
3. Sub power supply unit [A] (All ⚙'s, 🔩 x 4)

3.12.8 PSU

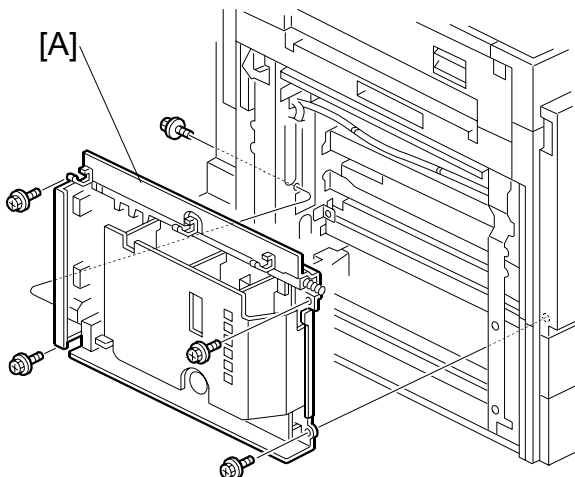

G130R625.WMFF

Replacement
Adjustment

1. Left cover (☛ 3.5.5)
2. PSU [A] (All ⚙'s, 🔩 x 5)

NOTE: Make sure that the interlock switches on the PSU operate correctly after you reinstall the PSU (open/close the left and front doors).

3.12.9 CIRCUIT BREAKER AND PSU FAN

1. PSU (☛ 3.12.8)
2. Circuit breaker bracket [A] (⚙ x 2, 🔩 x 2)
3. Circuit breaker [B] (⚙ x 4)
4. PSU fan bracket [C] (⚙ x 1, 🔩 x 2)
5. PSU fan [D] (🔩 x 2)

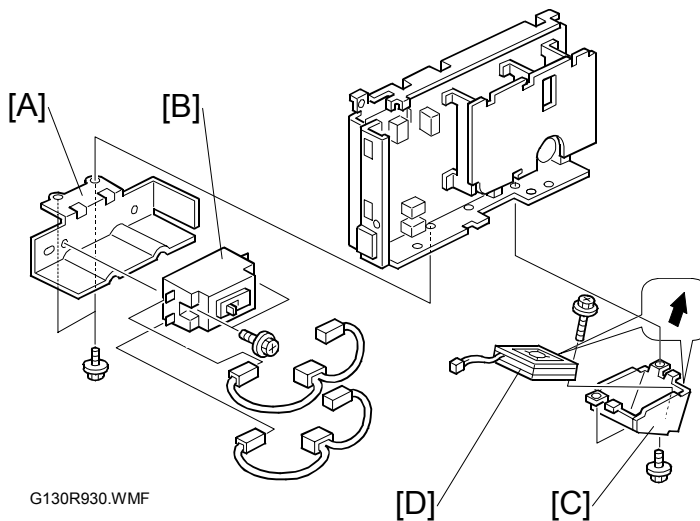

G130R930.WMF

Reassembling

Check that the arrows on the fan and the bracket point in the same direction.

3.12.10 CHOKE COIL

1. Left cover, rear left cover (☛ 3.5.5)
2. Tray 2
3. Choke coil bracket [A] (🔩 x 2)
4. Choke coil [B] (🔩 x 2, 📏 x 1)
NOTE: The connector is on the PSU.

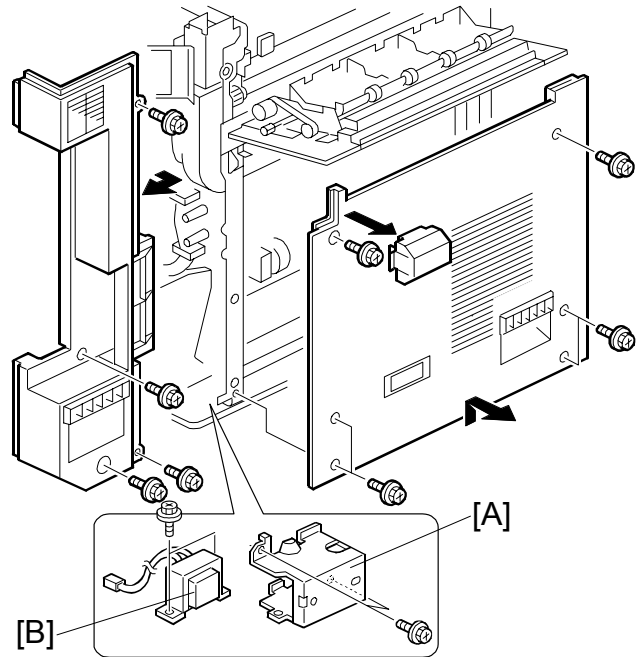

G130R929.WMFF

3.12.11 DRIVER BOARD

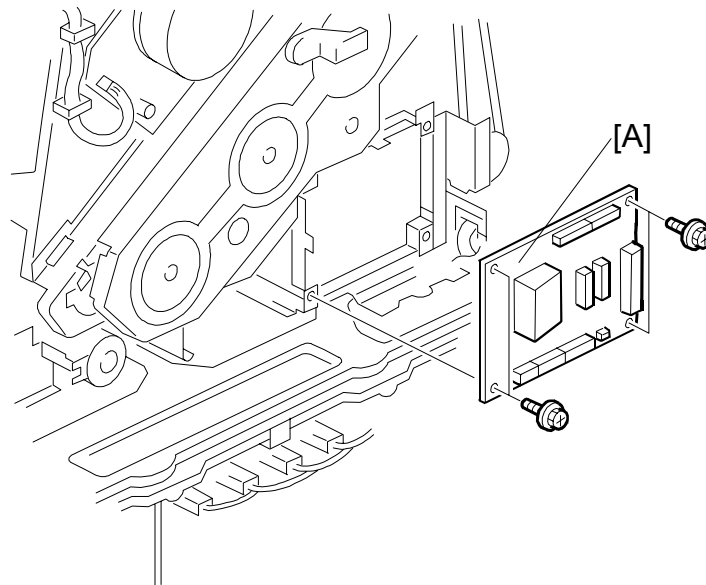

G130R626.WMFF

1. Rear cover (☛ 3.5.1)
2. Swing out the controller box (☛ 3.12.1).
3. Driver board [A] (All 📏's, 🔩 x 4)

3.13 DRIVE UNIT

3.13.1 REGISTRATION CLUTCH

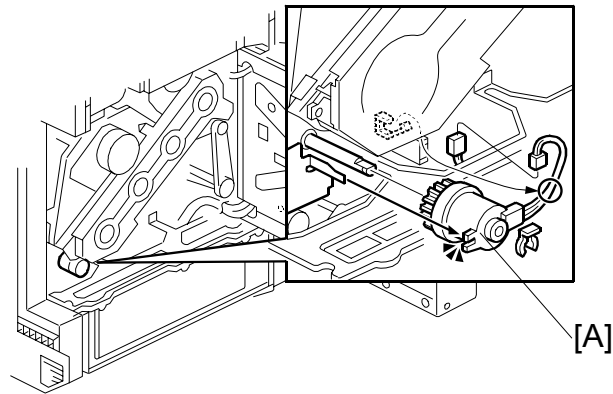

G130R627.WMFF

1. Rear cover (☛ 3.5.1)
2. Swing out the controller box (☛ 3.12.1).
3. Registration clutch [A] (☞ x 1, ☞ x 1)

3.13.2 DEVELOPMENT CLUTCHES

1. Drum gears (☛ 3.13.3).
2. Development clutch assembly [A] (☞ x 1, ☞ x 1)
3. Clutch holder [B]
4. Clutch shaft [C] (1 bushing, ☞ x 1, 1 hook)

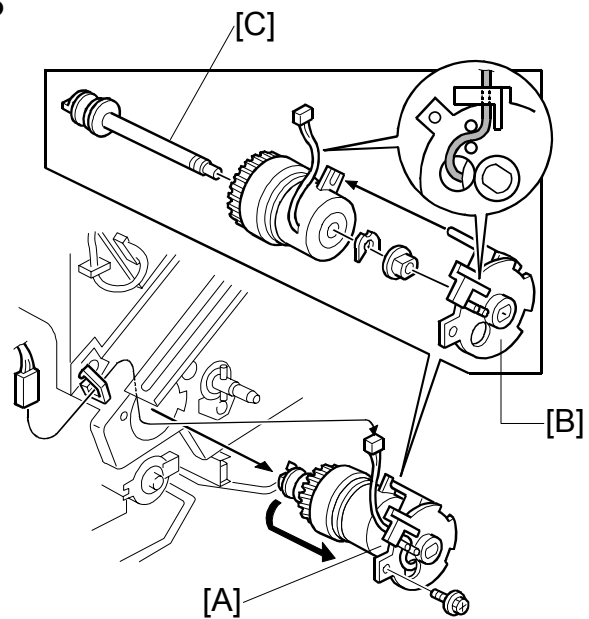

G130R628.WMFF

Replacement
Adjustment

3.13.3 DEVELOPMENT MOTOR - CMY

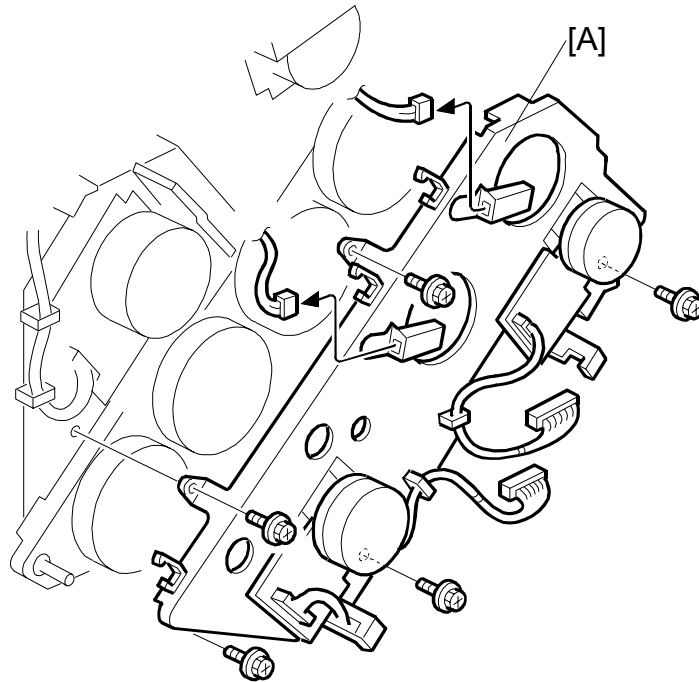

G130R629.WMFF

1. Rear cover (☛ 3.5.1)
2. Swing out the controller box (☛ 3.12.1).
3. Drum gear cover [A] (☛ x 4, ☛ x 5)

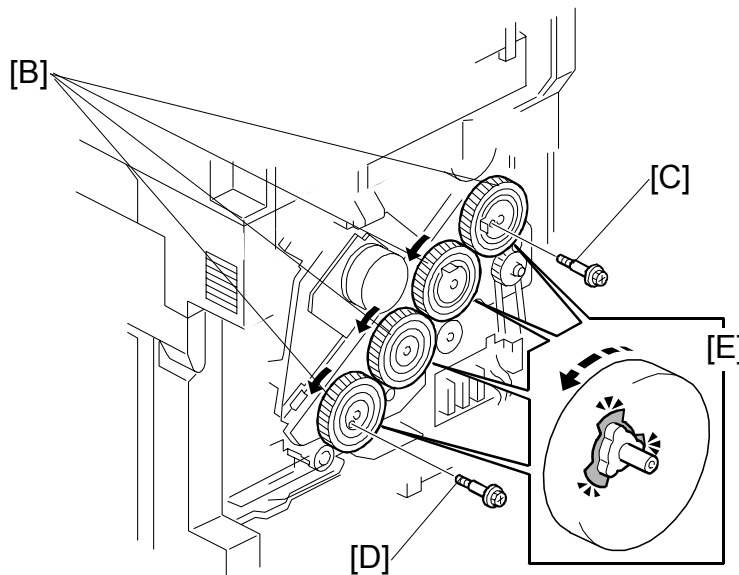

G130R630.WMFF

4. Turn the drum gears [B] counterclockwise. Make sure the shoulder screws [C][D] are in the three, seven, or eleven o'clock positions.

NOTE: You can align the three corners of each drum-gear shaft to the three openings on the development-clutch securing plate [E].

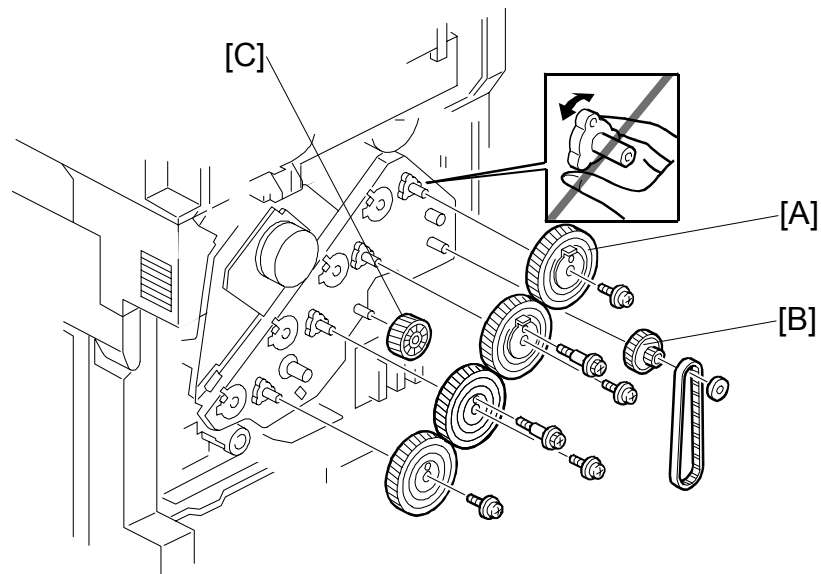

G130R631.WMFF

5. 4 drum gears [A] (⚙️ x 2 for each)

NOTE: 1) Do not move the drum-gear shafts after you remove the drum gears.
2) The print quality can be affected if the teeth on the drum gears are damaged. Check to make sure that they are not damaged.

6. Timing belt gear [B] (Timing belt x 1, Bushing x 1)
7. Idle gear [C]

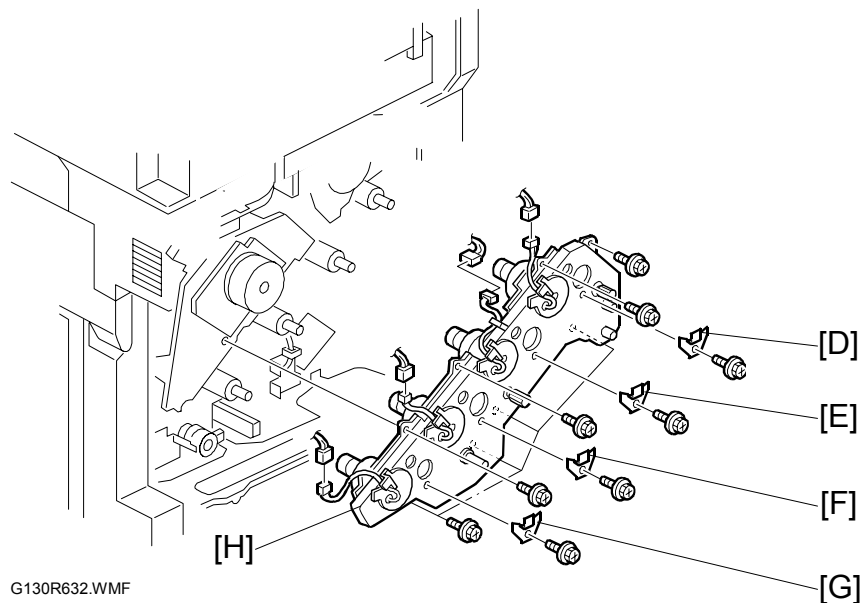

G130R632.WMF

8. 4 gear drive holders [D]~[G] (⚙️ x 1 for each)
9. Development clutch securing plate [H] (⚙️ x 8, 📌 x 4)

NOTE: Two of the six connectors are on the rear side.

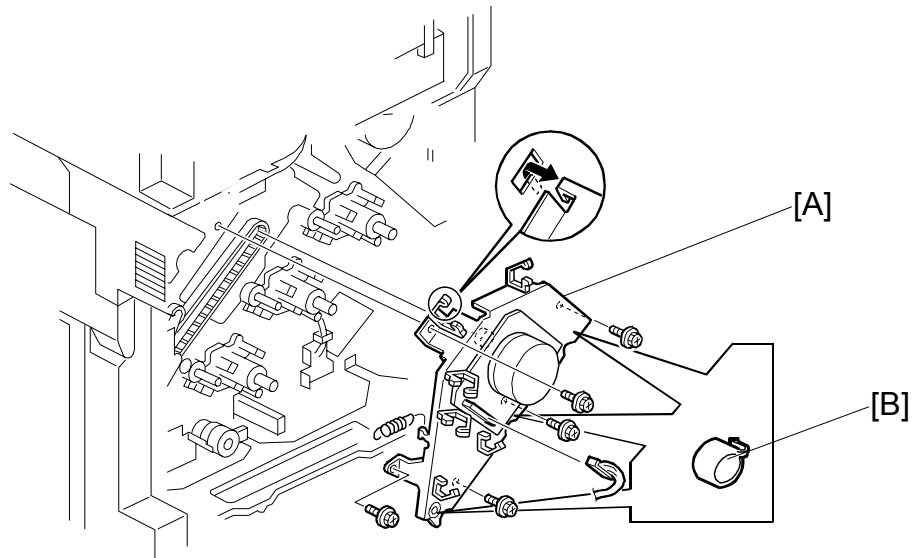

G130R633.WMFF

10. Development drive motor - CMY [A] (⚙ x 5, ⚙ x 1, Spring x 1)

NOTE: Remove the three bushings [B] and install the development drive motor first when you reassemble. Then install the bushings.

3.13.4 DRUM DRIVE MOTOR - CMY AND DRUM DRIVE MOTOR - K

1. Swing out the controller box (☛ 3.12.1)
2. Drum drive motor - CMY [A]
(⚙ x 6, ⚙ x 1)
3. Drum drive motor - K [B]
(⚙ x 6, ⚙ x 1)

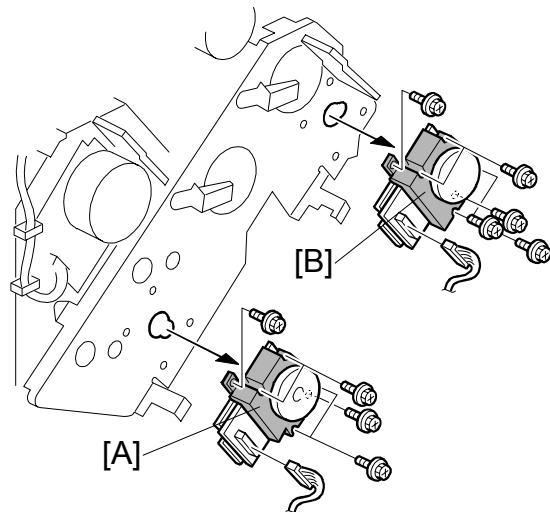

G130R646.WMFF

3.13.5 DEVELOPMENT DRIVE MOTOR - K

1. Fusing fan duct (☞ 3.11.13)
2. Development clutch securing plate (☞ 3.13.3)
3. Solenoid cover [A] (🔩 x 2)

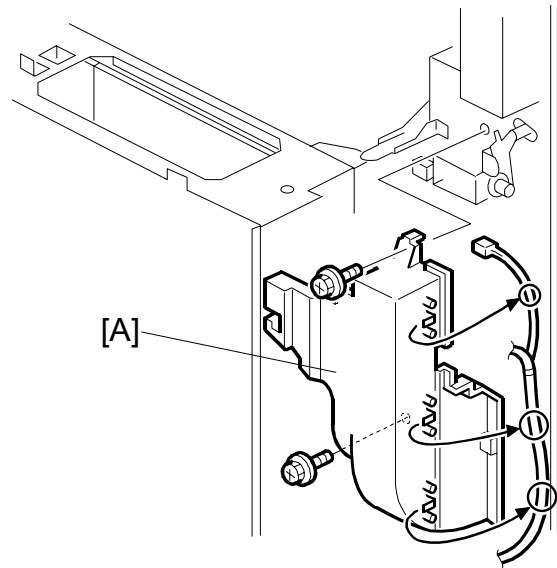

G130R635.WMFF

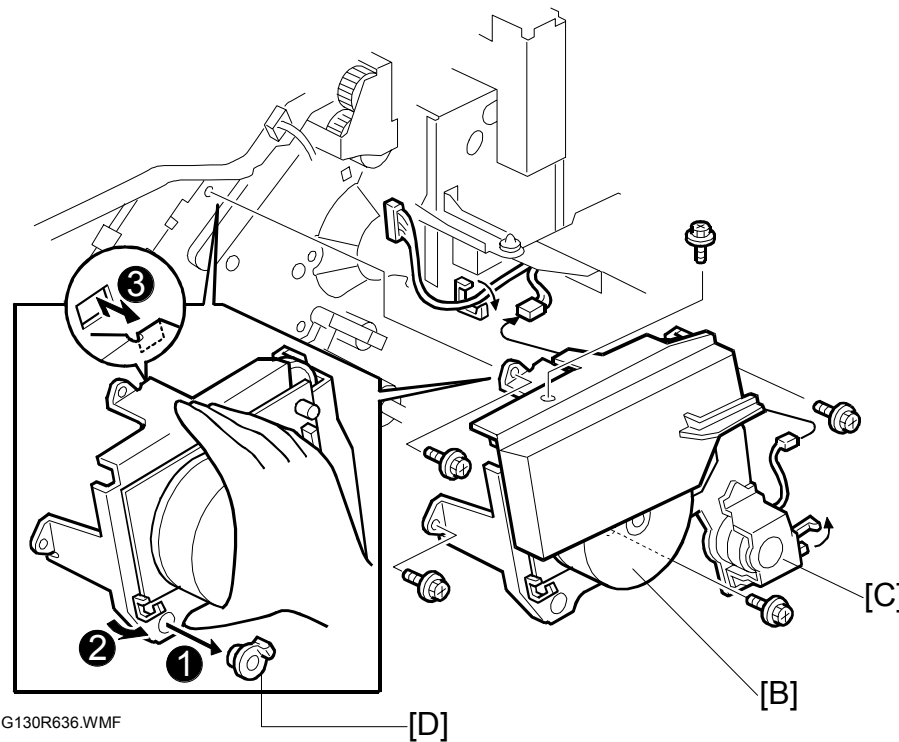

G130R636.WMFF

4. Development drive motor – K [B] (with the fusing clutch [C]) (🔩 x 4, 🛠 x 2)

NOTE: Remove the bushing [D] and install the development drive motor–K (with the fusing clutch) first when you reassemble. Then install the bushing.

3.14 TONER SUPPLY UNIT

- NOTE:** 1) Do not touch the PCU drum. Do not let metal objects touch the development sleeve.
2) Cover the PCUs with paper or cloth after you remove them. Keep them in a dark place.

M Toner Supply Unit

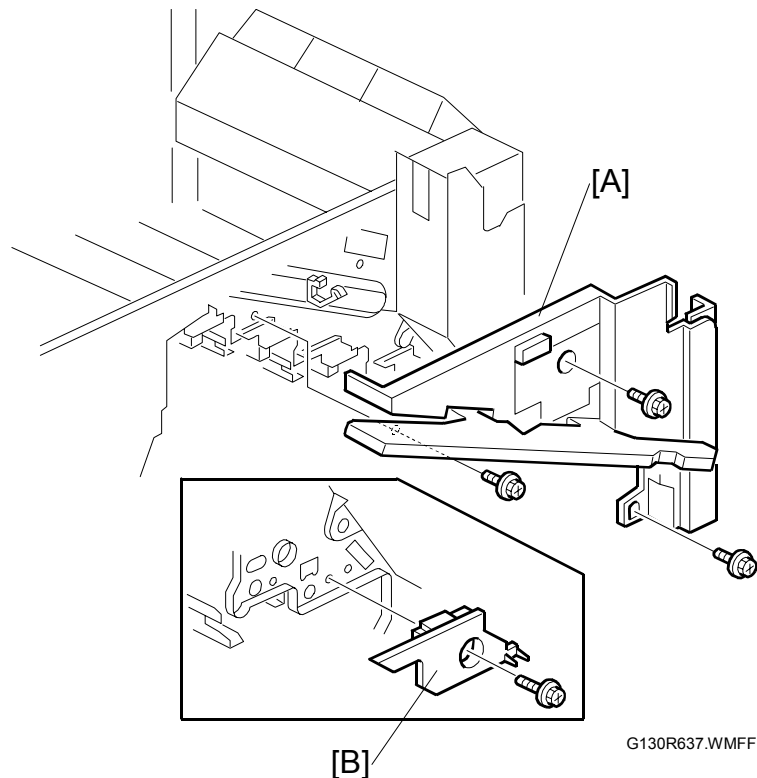

1. Laser optics housing unit (☛ 3.6.2)
2. All development units and PCUs (☛ 3.7)
3. Transfer unit (☛ 3.9.1)
4. Development clutch securing plate (☛ 3.13.3)
5. Right inner cover with the drum positioning plate [A] (🔩 x 3)
6. M development unit plate [B] (🔩 x 1)

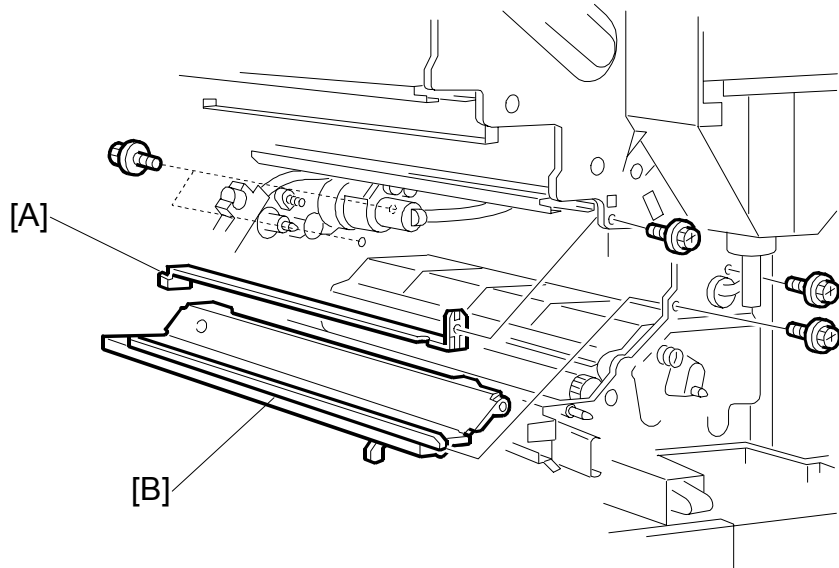

G130R638.WMFF

7. Development unit left guide [A] (🔩 x 1)
8. Open the right door.
9. Registration upper stay [B] (🔩 x 4)

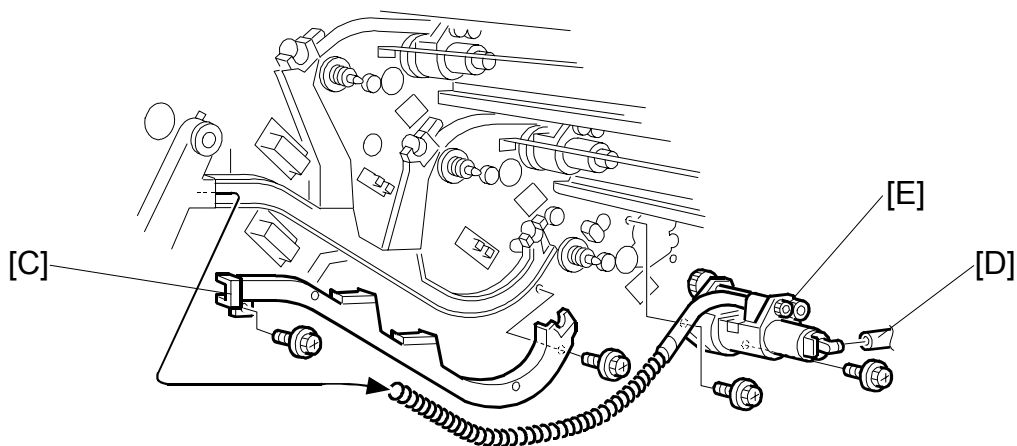

G130R639.WMFF

- CAUTION:** 1) Toner spills out when you remove the toner path cover and toner supply pipe. Put some paper or cloth under the toner supply unit and waste toner collection path before you remove them.
2) Use a paper clip or tape to close the pipe after you remove it.

10. Toner path cover [C] (🔩 x 2)
11. Toner supply pipe [D]
12. Toner supply unit [E] (🔩 x 2, 📎 x 1)

Reinstalling the M Toner Supply Unit

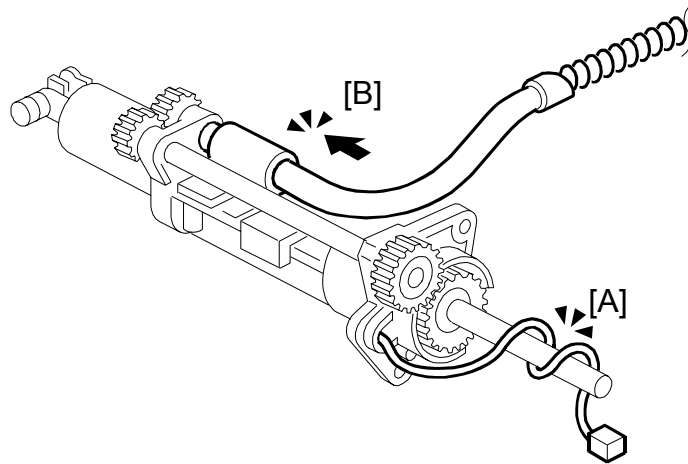

G130R640.WMFF

1. Wind the harness [A] on the shaft.
2. Insert the toner collection pipe [B].

NOTE: Make sure that the pipe does not come off the unit.

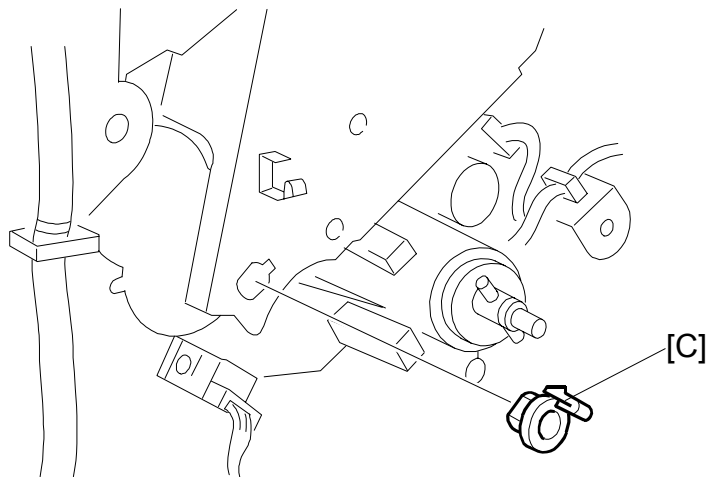

G130R641.WMFF

3. Remove the toner supply unit bushing [C].

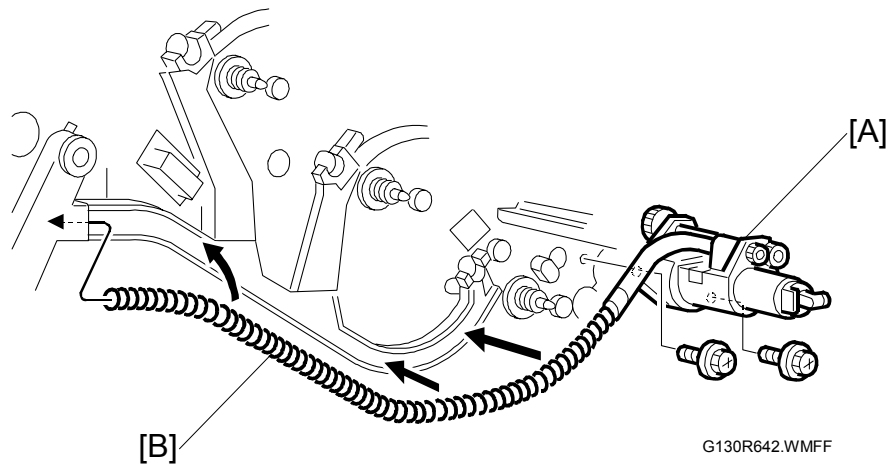

Replacement
Adjustment

4. Install the unit [A] and secure it with the screws.
5. Unwind the harness and connect it.
6. Install the bushing.
7. Connect the toner supply pipe and the waste toner collection pipe [B].
8. Check that the pipes [C] do not come off the unit.
9. Attach the toner path cover and secure it with screws.
10. Reassemble the machine.

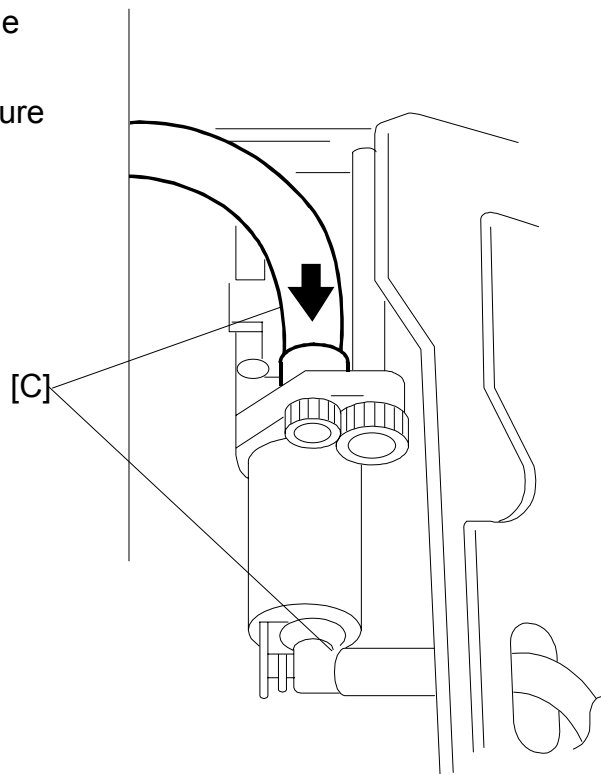

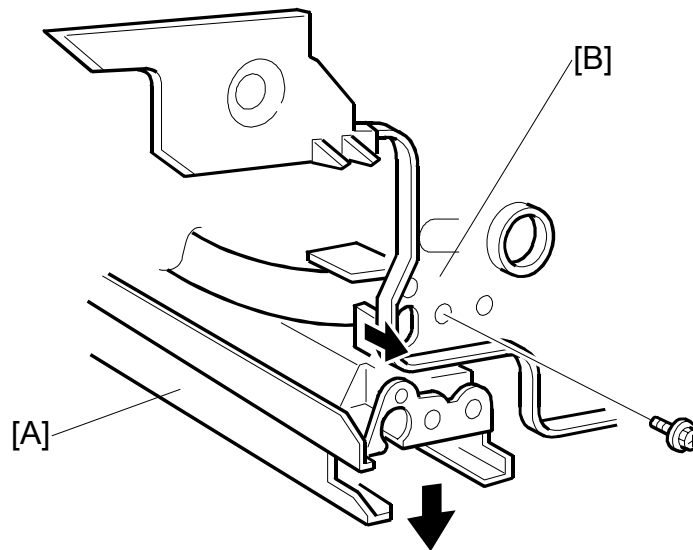
C and Y Toner Supply Units

G130R644.WMFF

1. Development drive motor - CMY (☛ 3.13.3)
2. Development unit plates (☛ M Toner Supply Unit)
3. Development unit left guide (☛ M Toner Supply Unit)
4. PCU 3C guide rail [A] (☛ x 2)

NOTE: 1) To replace the C toner supply unit, remove the M PCU guide. To replace the Y toner supply unit, remove the C PCU guide.
 2) Pull the front plate [B] slightly to the front side.

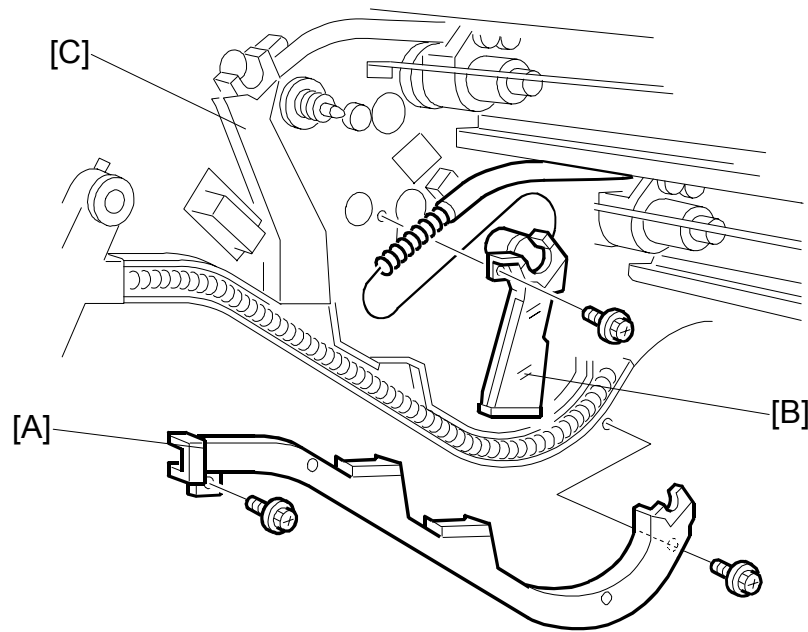

G130R645.WMFF

5. Toner path cover [A] (🔩 x 2)
6. Branch toner path covers [B][C] (🔩 x 1)

NOTE: To replace the C toner supply unit, remove the cover on the right-hand side [B]. To replace the Y toner supply unit, remove the cover on the left-hand side [C].

7. Toner supply pipe and toner supply unit (🔩 M Toner Supply Unit)

K Toner Supply Unit

1. K and Y development unit plates (🔩 M Toner Supply Unit)
2. Development unit left guide (🔩 M Toner Supply Unit)
3. PCU 3C guide rail (🔩 C and Y Toner Supply Units)
NOTE: Remove the Y PCU guide.
4. Toner supply unit (🔩 M Toner Supply Unit)

4. TROUBLESHOOTING

4.1 PROCESS CONTROL ERROR CONDITIONS

4.1.1 DEVELOPER INITIALIZATION RESULT

SP-3-005-006 (Developer Initialization Result)

No.	Result	Description	Possible Causes	Action
0	Not performed	Developer initialization is not performed.	When initializing only the black developer, the initialization result becomes "1000".	When done in SP mode, do the developer initialization again. Reinstall the engine main firmware if the result is the same. Do the following when done at unit replacement: <ul style="list-style-type: none"> • Check if a new unit is installed • Check if the unit detection system works correctly • Check if SP2-223-001 (auto initialization at unit replacement) is enabled.
1	Successfully completed	Developer initialization is successfully completed.		-
2	Forced termination	Developer initialization was forcibly terminated.	A cover was opened or the main switch was turned off during the initialization.	When done in SP mode, do the developer initialization again. Reinstall the engine main firmware if the result is the same. Turn the main switch off and on when done at unit replacement.
3	Vt error	Vt is less than 0.5V and "Reset development unit" is displayed.	1. Check if the drum stay is correctly set and secured. 2. Check if the development unit is correctly set. 3. Check the following if the problem stays: <ul style="list-style-type: none"> • Poor connection of connectors • TD sensor defective • Harness damage • BCU board failure • Firmware problem (engine main or MUSIC) 	

Trouble-shooting

No.	Result	Description	Possible Causes	Action
8	Toner supply error	During toner fill-up mode, Vt does not reach the target value.	<ol style="list-style-type: none"> 1. Check if the toner cartridge correctly set. 2. Check if the amount of toner left in the toner cartridge is sufficient. 3. Check if toner is coagulated. (Shake the toner cartridge well if it is.) 4. Check if the connectors of the following parts are correctly set, and/or replace the parts. Toner attraction pump / Air Pump / Valves 5. Check if the toner supply tube is bent, caught, or damaged. 	
9	Failure	Vt cannot be adjusted within $3.0 \pm 0.1V$. SC370 - 373 will be displayed. Turning the main switch off and on clears this SC code.	<ol style="list-style-type: none"> 1. Shielding tape is not removed. 2. Development unit is not firmly installed, causing poor connection of the TD sensor connector. 3. TD sensor defective. 	<ol style="list-style-type: none"> 1. Remove the shielding tape to supply developer to the unit. 2. Reinstall the development unit. 3. Replace the development unit.

NOTE: When the machine detects new development units, it automatically starts developer initialization. If an error other than Error 8 occurs, developer initialization is automatically resumed by opening and closing the front door or turning the main switch off and on.

4.1.2 PROCESS CONTROL SELF-CHECK RESULT

SP3-975-001 (Process Control Self-check Result)

No.	Result	Description	Possible Causes	Action
0	Not performed	Process control self-check is not done.	-	Do the process control self-check again.
1	Successfully completed	Process control self-check successfully completed.	-	-
2	ID sensor adjustment error	Vsg cannot be adjusted within $4.0 \pm 0.5V$.	<ol style="list-style-type: none"> 1. Dirty ID sensor (toner, dust, or foreign material) 2. Dirty transfer belt 3. Scratched or damaged transfer belt 4. Defective ID sensor 	<ol style="list-style-type: none"> 1. Clean the ID sensor. 2. Check the belt cleaning. Clean or replace the transfer belt. 3. Replace the transfer belt. 4. Replace the ID sensor.
3	Vmin error	Vmin is not within the specified range.	<p>Vmin is calculated during the self-check. Even when the calculated Vmin value is out of the specified range, an optimum value is automatically used instead. Therefore, this error code does not usually occur.</p> <p>If no problem is observed with image density and/or development gamma, nothing needs to be done.</p> <p>If an image problem such as low image density is observed, check the following points: Transfer belt / Belt guide plate / ID sensor</p>	
4	Sampling data error	Not enough data can be sampled.	<ol style="list-style-type: none"> 1. ID sensor pattern density is too high or low. 2. Residual image on transfer belt 3. Toner dropped from development unit 4. Scratched or damaged transfer belt 	<ol style="list-style-type: none"> 1. Check the image development process and correct toner density if necessary. 2. Check the transfer belt-cleaning unit. 3. Clean the development unit and correct toner density. 4. Replace the transfer belt.
5	Gamma error	Gamma is out of range. $0.3 > \text{Gamma}$, or $6.0 < \text{Gamma}$		
6	Vk error	Vk is out of range. $-150 > \text{Vk}$ or $150 < \text{Vk}$		
7	Vt error	Vt is out of range. $0.5 > \text{Vt}$ or $4.8 < \text{Vt}$	<ol style="list-style-type: none"> 1. Development unit not correctly installed. 2. Toner density is too low or high. 3. TD sensor defective. 	<ol style="list-style-type: none"> 1. Check. 2. Check and/or correct toner density. 3. Replace development unit.
8	Sampling data error during LD power correction	Not enough data can be sampled during the LD power correction (if "LD Power" is set in SP3-125-002).	See the possible causes and action for error codes 4, 5, and 6.	
9	Forced termination	Process control self-check was forcibly terminated.	A cover was opened or the main switch was turned off during the self-check.	Do the process control self-check again.

4.1.3 LINE POSITION ADJUSTMENT RESULT

SP5-993-007 (Line Position Adjustment Result)

This SP shows the six digits number as a line position adjustment result on the LCD. It shows which parts of the transfer belt has an error (front, center or rear).

- The first and second digits from left-hand indicate the result detected by the front ID sensor.
- The third and fourth digits indicate the result detected by the center ID sensor.
- The fifth and sixth digits indicate the result detected by the rear ID sensor.

No.	Result	Description	Note
01	Successfully completed	Data sampling was correctly done and line position adjustment was successfully completed.	
02	Out of adjustment range (over ± 2 mm)	The calculated result for line position correction is greater than ± 2.0 mm.	
03	Calculation Error	Distance between the lines is greater than ± 1.4 mm.	
04	Sampling Error	Data sampling cannot be done correctly.	
05	Descending slope error	The ascending or descending slope of the ID sensor signal wave is out of specification.	(See Note 1)
06	Ascending slope error		(See Note 1)
07	Pattern lines mismatch (less than 64 lines)	The detected number of pattern lines is less than 64 lines.	(See Note 1)
08	Sampling time-out	Data sampling cannot be done within the allocated time.	
09	Sampling start error	The start mark cannot be detected within the allocated time.	
10	Pattern length mismatch	The pattern length is shorter or longer than specified.	(See Note 1)
11	Pattern lines mismatch (over 64 lines)	The detected number of pattern lines is over 64 lines.	
12	Magnification mismatch	The calculated magnification value does not match any data in the laser power frequency adjustment data table.	
13	Toner condition	The machine is in the toner near-end or toner end condition.	
17	Not executed	The machine is not ready to do the line position adjustment manually from the user menu.	
18	Potential control error	Line position adjustment cannot be done due to failed potential control.	
19	Cyan line error	The necessary mirror angle correction is outside the adjustment range (cyan only).	
26	Yellow magnification error	The detected magnification value is out of the adjustment range (yellow only).	
27	Yellow sub scan registration error	The detected sub scan registration is out of the adjustment range (yellow only).	
28	Yellow main scan registration error	The detected main scan registration is out of the adjustment range (yellow only).	

No.	Result	Description	Note
29	Yellow skew correction error	The detected skew correction value is out of the adjustment range (yellow only).	
36	Cyan magnification error	The detected magnification value is out of the adjustment range (cyan only).	
37	Cyan sub scan registration error	The detected sub scan registration is out of the adjustment range (cyan only).	
38	Cyan main scan registration error	The detected main scan registration is out of the adjustment range (cyan only).	
39	Cyan skew correction error	The detected skew correction value is out of the adjustment range (cyan only).	
46	Yellow & cyan magnification error	The detected magnification value is out of the adjustment range (yellow + cyan).	
47	Yellow & cyan sub scan registration error	The detected sub scan registration is out of the adjustment range (yellow + cyan).	
48	Yellow & cyan main scan registration error	The detected main scan registration is out of the adjustment range (yellow + cyan).	
49	Yellow & cyan skew correction error	The detected skew correction value is out of the adjustment range (yellow + cyan).	
56	Magenta magnification error	The detected magnification value is out of the adjustment range (magenta only).	
57	Magenta sub scan registration error	The detected sub scan registration is out of the adjustment range (magenta only).	
58	Magenta main scan registration error	The detected main scan registration is out of the adjustment range (magenta only).	
59	Magenta skew correction error	The detected skew correction value is out of the adjustment range (magenta only).	
66	Yellow & magenta magnification error	The detected magnification value is out of the adjustment range (yellow + magenta).	
67	Yellow & magenta sub scan registration error	The detected sub scan registration is out of the adjustment range (yellow + magenta).	
68	Yellow & magenta main scan registration error	The detected main scan registration is out of the adjustment range (yellow + magenta).	
69	Yellow & magenta skew correction error	The detected skew correction value is out of the adjustment range (yellow + magenta).	
76	Cyan & magenta magnification error	The detected magnification value is out of the adjustment range (cyan + magenta).	
77	Cyan & magenta sub scan registration error	The detected sub scan registration is out of the adjustment range (cyan + magenta).	
78	Cyan & magenta main scan registration error	The detected main scan registration is out of the adjustment range (cyan + magenta).	
79	Cyan & magenta skew correction error	The detected skew correction value is out of the adjustment range (cyan + magenta).	

No.	Result	Description	Note
86	Yellow & cyan & magenta magnification error	The detected magnification value is out of the adjustment range (yellow + cyan + magenta).	
87	Yellow & cyan & magenta sub scan registration error	The detected sub scan registration is out of the adjustment range (yellow + cyan + magenta).	
88	Yellow & cyan & magenta main scan registration error	The detected main scan registration is out of the adjustment range (yellow + cyan + magenta).	
89	Yellow & cyan & magenta skew correction error	The detected skew correction value is out of the adjustment range (yellow + cyan + magenta).	

Note 1: Error codes (05, 06, 07 or 10) stop sampling data at following times: The front, center, or, rear ID sensor detect an error. The machine can show the error codes for all ID sensors in some cases.

Possible causes of errors in the line position adjustment

	Possible Cause	Possible Error Code	Action
1	The pattern does not reach the proper density.		
	1. Dirty ID sensor (toner, dust, or foreign material)	04, 05, 06, 07, 08, 09, 10	1. Clean the ID sensors.
	2. Incorrect toner density Low: ID sensor cannot detect the pattern lines. High: Lines may be partially blank due to incorrect toner density and/or paper transfer current.		2. Correct the toner density.
	3. Incorrect transfer current		3. Correct the transfer current.
The ID sensors are affected by electrical noise or dirt/damage on the transfer belt.			
2	1. Scratched or damaged OPC drum	02, 03, 04, 05, 06, 10, 11, 12	1. Replace PCU
	2. Scratched or damaged transfer belt		2. Replace transfer belt
	3. Dirty transfer belt		3. Clean or replace transfer belt
	4. High voltage leak in transfer unit		4. Fix the high voltage leak
	5. Residual image on transfer belt		5. Check transfer belt cleaning and clean the belt
	6. Toner dropped from development unit		6. Clean the development unit and adjust the toner density
	7. Carrier dropped from development unit		7. Clean the development unit and adjust the toner density
3	The transfer belt is covered with toner.		
	Development does not work correctly.	All error codes	Check all units and high voltage cable connectors.
4	None of the patterns is developed.		
	Development does not work correctly.	09, 04	Check all units and high voltage cable connectors.
5	Some of the patterns are not developed;		
	Development does not work correctly.	07, 08	Check all units and high voltage cable connectors.

	Possible Cause	Possible Error Code	Action
6	<p>The machine is not in the condition to execute the line position adjustment;</p> <p>The machine is in the toner near end or end condition.</p> <p>The machine is not ready to do the line position adjustment manually from the user menu.</p> <p>Line position adjustment cannot be done due to failed potential control.</p>	<p>13</p> <p>17</p> <p>18</p>	<p>Replenish toner.</p> <p>Wait until machine goes to the ready condition from the energy saver or auto off mode.</p> <p>Fix the problem causing the potential control error.</p>
7	<p>The MUSIC CPU is abnormal (1)</p> <p>No error code shows. However, the machine continues to show "execution" on the screen. In addition, the green LED on the BICU stays on or off under the following condition.</p> <p>1. The MUSIC CPU resets due to electrical noise generated by a high voltage leak on a damaged OPC drum.</p>		<p>1. Fix the bias leak and/or replace PCU</p>
8	<p>The MUSIC CPU is abnormal (2)</p> <p>No error code shows. However, the machine continues to show "execution" on the screen. The green LED on the BICU keeps blinking faintly (this is normal) even under the following conditions:</p> <p>1. Poor connection between the toner cartridge detection board and the memory chip on the toner cartridge</p> <p>2. The memory chip on the toner cartridge fails.</p>		<p>1. Check the connection between the detection board and memory chip.</p> <p>2. Replace the toner cartridge.</p>

Trouble-shooting

4.2 SERVICE CALL CONDITIONS

4.2.1 SUMMARY

Section 4.3 shows the SC codes for controller errors and other errors. The latter (not controller errors) are put into four types. The type is determined by their reset procedures. The table shows the classification of the SC codes.

	Key	Definition	Reset Procedure
Controller errors	CTL	The error has occurred in the controller.	See "Troubleshooting Procedure" in the table.
Other errors	A	The error involves the fusing unit. The machine operation is disabled. The user cannot reset the error.	Turn the main switch off and on. Reset the SC (set SP5-810-1). Turn the main switch off and on.
	B	The error involves one or some specific units. The machine operates as usual, excluding the related units.	Turn the operation switch off and on.
	C	The error is logged. The SC-code history is updated. The machine operates as usual.	The SC will not show. Only the SC history is updated.
	D	The machine operation is disabled. You can reset the machine by turning the operation switch or main switch off and on. If the error occurs again, the same SC code is displayed.	Turn the operation switch or main power switch off and on.

All SCs are logged. The print log data (SP5-990-004) in SP mode can check the latest 10 SC codes detected and total counters when the SC code is detected.

- NOTE:**
- 1) If the problem concerns electrical circuit boards, first disconnect then reconnect the connectors before you replace the PCBs.
 - 2) If the problem concerns a motor lock, first check the mechanical load before you replace motors or sensors.

SC Code Classification

The table shows the classification of the SC codes:

Class 1	Section	SC Code	Detailed section
1XX	Scanning	100 -	Scanner
		190 -	Unique for a specific model
2XX	Laser exposure	200 -	Polygon motor
		220 -	Synchronization control
		230 -	FGATE signal related
		240 -	LD control
		260 -	Magnification
		280 -	Unique for a specific model
		300 -	Charge
3XX	Image development 1	330 -	Drum potential
		350 -	Development
		380 -	Unique for a specific model
		400 -	Image transfer
4XX	Image development 2	420 -	Paper separation
		430 -	Cleaning
		440 -	Around drum
		460 -	Unit
		480 -	Others
		500 -	Paper feed
5XX	Paper feed / Fusing	515 -	Duplex
		520 -	Paper transport
		530 -	Fan motor
5XX	Paper feed / Fusing	540 -	Fusing
		560 -	Others
		570 -	Unique for a specific model
		600 -	Electrical counters
6XX	Communication	620 -	Mechanical counters
		630 -	Account control
		640 -	CSS
		650 -	Network
		670 -	Internal data processing
		680 -	Unique for a specific model
7XX	Peripherals	700 -	Original handling
		720 -	Two-tray finisher
		740 -	Booklet finisher
8XX	Controller	800 -	Error after ready condition
		820 -	Diagnostics error
		860 -	Hard disk
		880 -	Unique for a specific model
9XX	Others	900 -	Counter
		920 -	Memory
		990 -	Others

Trouble-
shooting

4.3 SC TABLE

SC No.	Item	Definition	Possible Cause	Related SCs	Troubleshooting Procedure	Type
SC 195	Serial Number Mismatch	Serial number stored in the memory does not have the correct code.	<ul style="list-style-type: none"> • NVRAM defective • BCU replaced without original NVRAM • Incorrect DIP-switch setting 		<p>Open the front cover and turn on the main switch. Check the serial number with SP5-811-002.</p> <p>If the stored serial number is incorrect, contact your supervisor.</p> <p>For DIP-switch settings, see section 5.8.</p>	D
SC 201	Polygon motor error	<ul style="list-style-type: none"> • The polygon mirror motor does not reach the targeted operating speed within 10 seconds after turning on. • The lock signal does not become high within 3 seconds after turning off the polygon motor. • The lock signal become high 0.2 second or more while the polygon motor reaches the targeted operating speed. 	<ul style="list-style-type: none"> • Polygon mirror motor error • Abnormal GAVD behavior • Cable disconnection 	SC 221-1 to 4	<ol style="list-style-type: none"> 1. Turn the main switch off and on. 2. Check the cables. 3. Replace the polygon motor. 	D

SC No.	Item	Definition	Possible Cause	Related SCs	Troubleshooting Procedure	Type
SC 220	Synch. detection signal error 1 220-001: Y 220-002: M 220-003: C 220-004: K0 220-005: K1	The front (for K&Y) or rear (for C&M) laser synchronizing detector board, (used to determine the start timing of laser writing), does not send a signal while the polygon motor operates normally and the LD is on.	<ul style="list-style-type: none"> • Disconnection of the cable between front (K&Y) or rear (C&M) synchronizing detector board and the LD unit • Incorrect installation of front (K&Y) or rear (C&M) synchronizing detector board (the beam does not target the photo detector.) • Defective LD unit • Defective BCU • Defective +5VLD circuit 	SC221-1 to 4	<ol style="list-style-type: none"> 1. Turn the main switch off and on. 2. Check the cable connection between front (for K&Y) or rear (for C&M) synchronizing detector board and the LD unit. 3. Check or reinstall the front (for K&Y) or rear (for C&M) synchronizing detector board. 4. Replace the front (for K&Y) or rear (for C&M) synchronizing detector board. 5. Replace the laser optics-housing unit. 6. Replace the BCU. 7. Replace the PSU. 	D

SC No.	Item	Definition	Possible Cause	Related SCs	Troubleshooting Procedure	Type
SC 221	Synch. detection signal error 2 221-001: Y 221-002: M 221-003: C 221-004: K	Main scan length detection is not correctly completed ten consecutive times. The front (for C&M) or rear (for K&Y) laser synchronizing detector boards are used for the main scan length detection, which automatically corrects the main-scan magnification.	<ul style="list-style-type: none"> • Damaged or disconnected cable between front (C&M) or rear (K&Y) laser synchronizing detector board and the LD unit • Incorrect installation of front (C&M) or rear (K&Y) synchronizing detector board (the beam does not target the photo detector.) • Defective front (C&M) or rear (K&Y) synchronizing detector board • Defective LD unit 	SC220-1 to 4	After doing one of the following, print ten jobs or more to see if the same SC code shows: <ol style="list-style-type: none"> 1. Turn the main switch off and on. 2. Check or replace the cable-connecting front (for C&M) or rear (for K&Y) synchronizing detector board and the LD unit. 3. Check or reinstall the front (for C&M) or rear (for K&Y) synchronizing detector board. 4. Replace the front (for C&M) or rear (for K&Y) synchronizing detector board. 5. Replace the laser optics-housing unit. 6. Replace the BCU. Do the following as a temporary measure if you cannot replace the synch. detector board: <ul style="list-style-type: none"> • Disable main scan length detection (SP 2-919-001) 	D

SC No.	Item	Definition	Possible Cause	Related SCs	Troubleshooting Procedure	Type
SC 230	FGATE error 230-001: Y 230-002: M 230-003: C 230-004: K	<ul style="list-style-type: none"> • The BCU generates the FGATE signal based on the registration sensor ON timing. Then it sends the signal to the LD units. The LD units send a feedback signal to the BCU. When the LD units start emitting laser beams, the feedback signal changes from High to Low. • The SC code generates when the BCU receives no feedback signal (stays High) from the LD unit 1 second after paper reaches the position where the laser should start writing. 	<ul style="list-style-type: none"> • Poor connection between BCU and LD units • Defective BCU • Defective LD unit 		<ol style="list-style-type: none"> 1. Turn the main switch off and on. 2. Check the cables between the LD units and the BCU. 3. Replace the laser optics-housing unit. 4. Replace the BCU. 	D
SC 231	FGATE timeout 231-001: Y 231-002: M 231-003: C 231-004: K	<p>When LD units emit laser beams to print a job, the feedback signal stays Low. The signal becomes High after laser exposure for a page is completed. The SC code is detected in the following cases:</p> <ul style="list-style-type: none"> • When the feedback signal stays Low 7 seconds after completing the laser exposure, or • When the feedback signal stays Low until the laser exposure timing for the next page in multi-page print mode. 	<ul style="list-style-type: none"> • Poor connection between BCU and LD units • Defective BCU • Defective LD unit 		<ol style="list-style-type: none"> 1. Turn the main switch off and on. 2. Check the cables between the LD units and the BCU. 3. Replace the laser optics-housing unit. 4. Replace the BCU. 	D

SC No.	Item	Definition	Possible Cause	Related SCs	Troubleshooting Procedure	Type
SC 240	LD over 240-001: Y 240-002: M 240-003: C 240-004: K	The power supply for the LD unit exceeds 110 mA.	<ul style="list-style-type: none"> LD worn out (current/light output characteristics have changed.) LD broken (short circuit) 		1. Replace the laser optics-housing unit.	C
SC 285	Line position adjustment (MUSIC) error	Line position adjustment fails four consecutive times.	<ul style="list-style-type: none"> Pattern sampling error due to insufficient image density of patterns used for the adjustment Inconsistency in the sampling line position adjustment pattern due to dust on the pattern, damage to the OPC drum, damage or toner dropped on the transfer belt, or a dirty or defective ID sensor 		<ol style="list-style-type: none"> Check and fix the problem that causes low image density. . Clean or replace the transfer belt and/or the ID sensor. Replace the PCU or clean the development unit that causes toner to drop on the transfer belt. 	C
SC 370	TD sensor [K]: Adjustment error	During the developer initialization, the output value of the TD sensor is out of the adjustment range ($X \pm 0.2V$). NOTE: "X" is adjusted with SP3-006-005 to -008.	<ul style="list-style-type: none"> Poor connection (TD sensor outputs is less than 0.5V.) Defective TD sensor 		<ol style="list-style-type: none"> Turn the main switch off and on. Reset the related color development unit. Replace the related color development unit. 	D
SC 371	TD sensor [Y]: Adjustment error					
SC 372	TD sensor [C]: Adjustment error					
SC 373	TD sensor [M] : Adjustment error					

SC No.	Item	Definition	Possible Cause	Related SCs	Troubleshooting Procedure	Type
SC 374	Vt error [K]	During the image development, Vt value is less than 0.78V.	<ul style="list-style-type: none"> Poor connection (TD sensor outputs is less than 0.5V.) Defective TD sensor 		<ol style="list-style-type: none"> Turn the main switch off and on. Reset the related color development unit. Replace the related color development unit. 	D
SC 375	Vt error [Y]					
SC 376	Vt error [C]					
SC 377	Vt error [M]					
SC 380	Black development motor error	When the motor speed is within the target level, the motor sends a lock signal (High to Low at CN608-5 [Black]/CN609-5 [Color]) to the DRB. SC380 is detected under the following conditions: <ul style="list-style-type: none"> The Lock signal stays High 2 seconds after the motor turns on. The Lock signal stays Low 2 seconds after the motor turns off. The Lock signal stays High for more than 2 seconds while the motor is on. 	<ul style="list-style-type: none"> Defective motor Defective BCU 		<ol style="list-style-type: none"> Turn the main switch off and on. Replace the motor. Replace the BCU. 	D
SC 381	Color development motor error					
SC 385	ID sensor VSG adjustment error	Vsg is the out of adjustment range during a process control self-check. Adjustment range: $\pm 0.5V$	<ul style="list-style-type: none"> Defective ID sensor Dirty ID sensor ID sensor disconnected Dirty drum (cleaning incomplete) 		<ol style="list-style-type: none"> Turn the main switch off and on. Clean the ID sensor and adjacent parts. Check the drum cleaning condition. Check the ID sensor connector. Replace the ID sensor. 	D



SC No.	Item	Definition	Possible Cause	Related SCs	Troubleshooting Procedure	Type
SC 386	Development gamma error K	If the following conditions happen three consecutive times: <ul style="list-style-type: none"> When the development gamma is out of the following range: $0.3 \leq \gamma \leq 6.0$ When V_k is out of the following range: $-150V \leq V_k \leq 150V$ Development gamma calculation error 	<ul style="list-style-type: none"> Unsuitable toner density Toner supply mechanism problem Laser exposure problem Image transfer problem 		<ol style="list-style-type: none"> Turn the main switch off and on. Check the process control self-check result (SP3-975). If the result is not "1", fix the problem according to the table in section 4.1.2. Print a full color image by disabling SC detection (SP5-809-001) and check if the image quality is OK. If the image quality is not OK, fix the problem. Then enable the SC detection again. 	D
SC 387	Development gamma error Y					
SC 388	Development gamma error C					
SC 389	Development gamma error M					
SC 390	Development Bias output error	<ul style="list-style-type: none"> The high voltage supply board (C/B) checks the circuit and detects abnormal conditions such as a voltage leak or no output condition. If this happens, the high voltage supply board sends an error signal (High to Low at CN204-A18) to the BCU. The BCU checks this signal every 2 ms and generates this SC code when the error condition occurs 250 consecutive times. 	<ul style="list-style-type: none"> Loose connection Defective power pack C/B output Damaged cable Defective development unit Defective BCU 		<ol style="list-style-type: none"> Turn the main switch off and on. Check if the harness and cables are correctly connected. Disconnect the high voltage supply cables from the bias terminals on the high voltage supply board C/B. Measure the DC voltage with a multi-meter. <ul style="list-style-type: none"> Replace the high voltage supply board if no voltage is supplied. If the result is OK at step 2, check if the high voltage supply cable or development unit is grounded. <ul style="list-style-type: none"> Replace the high voltage supply cable if it is damaged. Replace the development unit if it is damaged. Check if the PWM signals are sent to the high voltage supplied board from the BCU. Replace the BCU or harness between the BCU and high voltage supply board if the voltage is 0. 	D

SC No.	Item	Definition	Possible Cause	Related SCs	Troubleshooting Procedure	Type
SC 391	Charge AC: output error 391-01: K 391-02: Y 391-03: M 391-04: C	The high voltage supply board sends the feedback signal (CN203-2 to 5; MCYK). The BCU checks these feedback signals every 8 ms. If the average of the sampled data is not within the control target 20 consecutive times, this SC code is generated.	<ul style="list-style-type: none"> Power pack disconnected Charge receptacle or terminal Defective PCU bias input terminal Incorrect power pack B/C output Damaged cable Defective BCU PCU not found 		<ol style="list-style-type: none"> Turn the main switch off and on. Check the connector. Check that the PCU is correctly installed. Check the PCU charge voltage input (the spring/conducting shaft) or replace the PCU. Replace the power pack B/C. Replace the cable. Replace the BCU. 	D
SC 392	Air pump motor error 392-001: MY 392-002: CK	Three consecutive errors are detected in motor-driver-signal samples. The samples are collected every 0.01 second.	<ul style="list-style-type: none"> Damaged cable Short circuit Defective motor 		<ol style="list-style-type: none"> Turn the main switch off and on. Replace the air pump. Check the circuit. 	D
SC 440	Drum motor error 440-001: Black 440-002: Color	No drum gear position sensor signal is detected within 0.8 second (G130: 125 mm/s, G131: 162 mm/s) or 2.0 seconds (81 mm/s).	<ul style="list-style-type: none"> Defective PCU Defective drum motor Defective drum gear position sensor 		<ol style="list-style-type: none"> Turn the main switch off and on. Check and/or replace the PCU. Check and/or replace the sensor. 	D
SC 460-001	Thermistor 1 error (open circuit)	When the temperature detected by thermistor 1, which is at the left (fusing unit) side of the laser optics unit, is less than -30°C for 10 seconds consecutively, the BCU determines that the circuit is open and shows this SC code.	<ul style="list-style-type: none"> Thermistor 1 defective Cable connection error BCU defect 		<ol style="list-style-type: none"> Check the cable connections. Replace the thermistor. Replace the BCU. 	C

SC No.	Item	Definition	Possible Cause	Related SCs	Troubleshooting Procedure	Type
SC 460-002	Thermistor 1 error (short circuit)	When the temperature detected by the thermistor 1, which is at the left (fusing unit) side of the laser optics unit, is higher than 70°C for 10 seconds consecutively, the BCU determines that the circuit is shorted and shows this SC code.	<ul style="list-style-type: none"> • Thermistor 1 defective • Cable connection error • BCU defect 		<ol style="list-style-type: none"> 1. Check the cable connections. 2. Replace the thermistor. 3. Replace the BCU. 	C
SC 461-001	Thermistor 2 error (open circuit)	When the temperature detected by the thermistor 2, which is at the right (paper feed section) side of the laser optics unit, is less than -30°C for 10 seconds consecutively, the BCU determines that the circuit is open and shows this SC code.	<ul style="list-style-type: none"> • Thermistor 2 defective • Cable connection error • BCU defect 		<ol style="list-style-type: none"> 1. Check the cable connections. 2. Replace the thermistor. 4. Replace the BCU. 	C
SC 461-002	Thermistor 2 error (short circuit)	When the temperature detected by the thermistor 2, which is at the right (paper feed section) side of the laser optics unit, is higher than 70°C for 10 seconds consecutively, the BCU determines that the circuit is shorted and shows this SC code	<ul style="list-style-type: none"> • Thermistor 2 defective • Cable connection error • BCU defect 		<ol style="list-style-type: none"> 1. Check the cable connections. 2. Replace the thermistor. 3. Replace the BCU. 	C

SC No.	Item	Definition	Possible Cause	Related SCs	Troubleshooting Procedure	Type
SC 471	Transfer belt H.P. error	The transfer belt HP sensor signal does not change from Low to High (home position) or vice-versa 1 second after the transfer belt contact motor turns on.	<ul style="list-style-type: none"> Transfer belt unit not set correctly Defective transfer belt H.P. sensor and/or transfer belt sensor Defective transfer belt contact motor Transfer belt unit problem 		<ol style="list-style-type: none"> Turn the main switch off and on. Reset the transfer belt unit. Clean or replace the transfer belt sensor. Replace the transfer belt contact motor. Check the contact and release mechanism of the transfer belt unit. 	D
SC 481	Waste toner vibrator error	The waste toner vibrator does not operate.	<ul style="list-style-type: none"> Loose connector Defective motor 		<ol style="list-style-type: none"> Turn the main switch off and on. Replace the motor. 	D
SC 490	Transfer bias / paper attraction roller bias leak error	<ul style="list-style-type: none"> The high voltage supply board transfer checks the circuit and detects current leaks. If this happens, the high voltage supply board sends a SC signal (High to Low at CN215-6) to the BCU. The BCU checks this signal every 2 ms and generates this SC code when the error condition occurs 250 consecutive times. 	<ul style="list-style-type: none"> Defective high voltage supply board - Transfer Damaged transfer belt Transfer unit Damaged high voltage supply cables Damaged cables between the BCU and high voltage supply board Defective BCU 		<ol style="list-style-type: none"> Turn the main switch off and on. Check the transfer unit and replace the belt and/or the transfer unit if it is damaged. Replace the high voltage supply board - Transfer. Check and/or replace the high voltage supply cables. Check and/or replace the dc cables between the BCU and high voltage supply board. Replace the BCU. 	D
SC 501	Paper Tray 1 error	When the tray lift motor is turned on, (if the upper limit is not detected within 10 seconds), the machine asks the user to reset the tray. If this condition occurs three consecutive times, the SC is generated.	<ul style="list-style-type: none"> Defective paper lift sensor Defective tray lift motor Defective bottom plate lift mechanism 		<ol style="list-style-type: none"> Turn the main switch off and on. Check if the bottom plate smoothly moves up and down manually. Check and/or replace the paper lift sensor. Check and/or replace the tray lift motor. 	B
SC 502	Paper Tray 2 error					

SC No.	Item	Definition	Possible Cause	Related SCs	Troubleshooting Procedure	Type
SC 503-01	Tray 3 error (Paper Feed Unit or LCT)	<p>For the paper feed unit:</p> <ul style="list-style-type: none"> When the tray lift motor is turned on, (if the upper limit is not detected within 18 seconds), the machine asks the user to reset the tray. If this condition occurs three consecutive times, the SC is generated. <p>For the LCT:</p> <ul style="list-style-type: none"> This SC is generated under the following conditions: If the upper or lower limit is not detected within 15 seconds when the tray lift motor is turned on to lift up or lower the tray If the paper stack is not transported within a specific number of pulses after the tray motor and stack transport clutch turn on to transport the paper stack If the end fence home position sensor stays ON for a specific number of pulses after the tray motor and stack transport clutch turn on to transport the paper stack. 	<p>For the paper feed unit:</p> <ul style="list-style-type: none"> Defective tray lift motor or connector disconnection Defective lift sensor or connector disconnection <p>For the LCT:</p> <ul style="list-style-type: none"> Defective stack transport clutch or connector disconnection Defective tray motor or connector disconnection Defective end fence home position sensor or connector disconnection Defective upper limit sensor or connector disconnection Defective tray lift motor or connector disconnection 		<ol style="list-style-type: none"> Turn the main switch off and on. Check the cable connections. Check and/or replace the defective component. 	B

SC No.	Item	Definition	Possible Cause	Related SCs	Troubleshooting Procedure	Type
SC 503-02	Tray 3 error (Paper Feed Unit or LCT)	<p>This SC is generated if the following condition occurs 3 consecutive times.</p> <p>For the paper feed unit:</p> <ul style="list-style-type: none"> • When the main switch is turned or when the tray is set and if the upper limit is already detected, the lift motor turns on to lower the bottom plate until the lift sensor goes off. • If the motor turns on for 7 seconds or more, the machine asks the user to reset the tray. <p>For the LCT:</p> <ul style="list-style-type: none"> • When the main switch is turned on or when the LCT is set, if the end fence is not in the home position (home position sensor ON), the tray lift motor stops. 	<p>For the paper feed unit:</p> <ul style="list-style-type: none"> • Defective tray lift motor or connector disconnection • Defective lift sensor or connector disconnection • <p>For the LCT:</p> <ul style="list-style-type: none"> • Defective stack transport clutch or connector disconnection • Defective tray motor or connector disconnection • Defective end fence home position sensor or connector disconnection 		<ol style="list-style-type: none"> 1. Turn the main switch off and on. 2. Check the cable connections. 3. Check and/or replace the defective component. 	B
SC 504-01	Tray 4 error (3 Tray Paper Feed Unit)	<p>When the tray lift motor is turned on, (if the upper limit is not detected within 18 seconds), the machine asks the user to reset the tray. If this condition occurs three consecutive times, the SC is generated.</p>	<ul style="list-style-type: none"> • Defective tray lift motor or connector disconnection • Defective lift sensor or connector disconnection 		<ol style="list-style-type: none"> 1. Turn the main switch off and on. 2. Check the cable connections. 3. Check and/or replace the defective component. 	B

SC No.	Item	Definition	Possible Cause	Related SCs	Troubleshooting Procedure	Type
SC 504-02	Tray 4 error (3 Tray Paper Feed Unit)	When the main switch is turned on or when the tray is set and if the upper limit is already detected, the lift motor turns on to lower the bottom plate until the lift sensor goes off. If the motor turns on for 7 seconds or more, the machine asks the user to reset the tray. If this condition occurs 3 consecutive times, this SC is generated.	<ul style="list-style-type: none"> Defective tray lift motor or connector disconnection Defective lift sensor or connector disconnection 		<ol style="list-style-type: none"> Turn the main switch off and on. Check the cable connections. Check and/or replace the defective component. 	B
SC 530	Fusing fan motor error	The BCU does not receive the lock signal (CN212-B8) 5 seconds after turning on the fusing fan.	<ul style="list-style-type: none"> Defective fusing fan motor or connector disconnection Defective BCU 		<ol style="list-style-type: none"> Turn the main switch off and on. Check the connector and/or replace the fusing fan motor. Replace the BCU. 	D
SC 541	Heating roller thermistor error	The temperature measured by the heating roller thermistor does not reach 7 °C for ten seconds.	<ul style="list-style-type: none"> Loose connection of the heating roller thermistor Defective heating roller thermistor Defective BCU 		<ol style="list-style-type: none"> Check if the heating roller thermistor is firmly connected. Replace the fusing unit. Replace the BCU. 	A
SC 542	Heating roller warm-up error	The heating roller temperature does not reach 120°C for 30 (G131) / 60 (G130) seconds after the heating lamp has been turned on.	<ul style="list-style-type: none"> Heating roller fusing lamp broken Defective heating roller thermistor 	SC 552	<ol style="list-style-type: none"> Check if the heating roller thermistor is firmly connected. Replace the fusing unit. Replace the BCU. 	A
SC 543	Heating roller fusing lamp overheat	The detected fusing temperature stays at 250°C or more for 2 seconds.	<ul style="list-style-type: none"> Defective PSU Defective BCU 	SC 553	<ol style="list-style-type: none"> Replace the PSU. Replace the BCU. 	A

SC No.	Item	Definition	Possible Cause	Related SCs	Troubleshooting Procedure	Type
SC 544	Heating roller fusing lamp high temperature error	During stand-by mode or a print job, the detected heating roller temperature stays at 230 °C or more for 0.2 second.	<ul style="list-style-type: none"> Defective heating roller thermistor Defective PSU Defective BCU 	SC 543	<ol style="list-style-type: none"> Replace the fusing unit. Replace the PSU. Replace the BCU. 	A
SC 545	Heating roller fusing lamp consecutive full power	When the fusing unit is not running in the Ready condition, the heating roller fusing lamp keeps on with full power for 35 consecutive seconds.	<ul style="list-style-type: none"> Heating roller thermistor out of position 	SC 555	<ol style="list-style-type: none"> Replace the fusing unit. 	A
SC 551	Pressure roller thermistor error	The measured pressure roller temperature does not reach 7°C for 60 seconds.	<ul style="list-style-type: none"> Loose connection of pressure roller thermistor Defective pressure roller thermistor Defective BCU 	SC 541	<ol style="list-style-type: none"> Check that the pressure roller thermistor is firmly connected. Replace the fusing unit. Replace the BCU. 	A
SC 552	Pressure roller warm-up error	After the main switch is turned on or the door is closed, the pressure roller temperature does not reach the ready temperature within 210 seconds during fusing unit warm-up.	<ul style="list-style-type: none"> Pressure roller fusing lamp broken Defective pressure roller thermistor Defective BCU 	SC 542	<ol style="list-style-type: none"> Check if the pressure roller thermistor is firmly connected. Replace the fusing unit. Replace the BCU. 	A
SC 553	Pressure roller fusing lamp overheat	The detected pressure roller temperature stays at 210°C or more for five seconds.	<ul style="list-style-type: none"> Defective PSU Defective BCU 	SC 543	<ol style="list-style-type: none"> Replace the fusing unit. Replace the PSU. Replace the BCU. 	A
SC 555	Pressure roller fusing lamp consecutive full power	When the fusing unit is not running in the Ready condition, the pressure roller-fusing lamp keeps ON with full power for 300 consecutive seconds.	<ul style="list-style-type: none"> Pressure roller thermistor out of position 	SC 545	<ol style="list-style-type: none"> Replace the fusing unit. 	A

SC No.	Item	Definition	Possible Cause	Related SCs	Troubleshooting Procedure	Type
SC 560	Zero cross error	When the main switch is turned on, the machine checks how many zero-cross signals are generated during 500 ms. If the number of zero-cross signal generated is either more than 66 or less than 45 and when this condition is detected 10 consecutive times, this code is displayed.	<ul style="list-style-type: none"> Electrical noise in the supply from the power cord 		<ul style="list-style-type: none"> 1. Replace the PSU. 	A
SC 621	Two-tray finisher/booklet finisher communication error	While the BCU communicates with an optional unit, an SC code is displayed if one of following conditions occurs. 1. The BCU receives the break signal which is generated by the peripherals only just after the main switch is turned on. 2. When the BCU does not receive an OK signal from a peripheral 100ms after sending a command to it. The BCU resends the command. The BCU does not receive an OK signal after sending the command 3 times.	<ul style="list-style-type: none"> Cable problems BCU problems PSU problems in the machine Main board problems in the peripherals 		<ol style="list-style-type: none"> Turn the main switch off and on. Check if the cables of peripherals are correctly connected. Replace the PSU if no power is supplied to peripherals. Replace the BCU or main board of peripherals. 	D
SC 622	Bank communication error					D
SC 623	Duplex unit communication error					D

SC No.	Item	Definition	Possible Cause	Related SCs	Troubleshooting Procedure	Type
SC 670	No response from BCU at power on	When the main power is turned on or the machine starts warming up from energy-saving mode, the controller does not receive a command signal from the BCU.	<ul style="list-style-type: none"> Loose connection Defective controller Defective BCU 		<ol style="list-style-type: none"> Turn the main switch off and on. Check the connection between the BCU and controller. Replace the controller. Replace the BCU. 	CTL
SC 680	BCU/ MUSIC communication error	After the engine CPU sends a message, the Music CPU does not respond within five seconds three consecutive times.	<ul style="list-style-type: none"> Toner cartridge memory chip loose connection Memory chip problem Memory chip cable wiring problem 		<ol style="list-style-type: none"> Turn the main switch off and on. Check if the toner cartridge is installed correctly. Replace the toner cartridge. Check if the harnesses are not damaged. Replace the BCU. 	D
SC 687	Memory address command error	The BCU does not receive a memory address command from the controller 120 seconds after paper is in the position for registration.	<ul style="list-style-type: none"> Loose connection Defective controller Defective BCU 		<ol style="list-style-type: none"> Turn the main switch off and on. Check if the controller is firmly connected to the BCU. Replace the controller. Replace the BCU. 	D
SC 690	GAVD communication error 690-001: Y 690-002: M 690-003: C 690-004: K	The register test of the GAVD fails.	<ul style="list-style-type: none"> Loose connection Defective BCU Defective LD controller board 		<ol style="list-style-type: none"> Turn the main switch off and on. Check the cable connection. Replace the laser optics-housing unit. Replace the BCU board. 	D
SC 692	GAPCI2C communication error	<ul style="list-style-type: none"> The I2C bus device ID is not identified during initialization. A device-status error occurs during I2C bus communication. The I2C bus communication is not established due to an error other than a buffer shortage. 	<ul style="list-style-type: none"> Loose connection Defective BCU Defective LD controller board 		<ol style="list-style-type: none"> Turn the main switch off and on. Check the cable connection. Replace the BCU. 	D

SC No.	Item	Definition	Possible Cause	Related SCs	Troubleshooting Procedure	Type
SC 722	Two-tray finisher jogger motor error	<ul style="list-style-type: none"> The jogger fences of the two-tray finisher donot return to home position within a specific time. The two-tray finisher jogger motor does not leave home position within a given time. 	<ul style="list-style-type: none"> Defective jogger H.P. sensor Loose connection Defective jogger motor 		<ol style="list-style-type: none"> Turn the main switch off and on. Check the connection of jogger H.P. sensor and jogger motor connectors Replace the jogger H.P. sensor. Replace the jogger motor. 	B
SC 724	Two-tray finisher staple hammer motor error	Stapling does not finish within 150 ms after the staple hammer motor turns on.	<ul style="list-style-type: none"> Staple jam Loose connection Overload caused by stapling too many pages Defective staple hammer motor 		<ol style="list-style-type: none"> Turn the main switch off and on. Check if the staple hammer motor connector is correctly connected. Check if the staple jam occurs. Replace the staple hammer motor. 	B
SC 725	Two-tray finisher stack feed-out motor error	The stack feed-out belt H.P. sensor does not activate within a specified time after the stack feed-out motor turns on.	<ul style="list-style-type: none"> Defective stack feed-out H.P. sensor Loose connection Stack feed-out motor overload Defective stack feed-out motor 		<ol style="list-style-type: none"> Turn the main switch off and on. Check if the connectors of the stack feed-out H.P. sensor and motor are correctly connected. Replace the stack feed-out H.P. sensor. Replace the stack feed-out motor. 	B

SC No.	Item	Definition	Possible Cause	Related SCs	Troubleshooting Procedure	Type
SC 726	Two-tray finisher shift tray 1 lift motor error	<ul style="list-style-type: none"> The upper stack height 1 sensor is activated consecutively (detecting paper) for 15 seconds after the shift tray starts moving up. The upper stack height sensor 1 is deactivated consecutively (not detecting paper) for 15 seconds after the shift tray starts moving down. When the upper tray moves from lower paper exit to the upper paper exit, the upper stack height 1 sensor is activated. 	<ul style="list-style-type: none"> Loose connection Defective upper stack height 1 sensor Defective shift tray 1 lift motor Motor overload 		<ol style="list-style-type: none"> Turn the main switch off and on. Check if the connectors of the sensor and motor are correctly connected. Replace the upper stack height 1 sensor. Replace the shift tray 1 lift motor. 	B
SC 727	Two-tray finisher stapler rotation motor error	The stapler cannot return to its home position within a specified time after the stapler rotation motor starts rotating.	<ul style="list-style-type: none"> Loose connection Defective stapler rotation motor Motor overload 		<ol style="list-style-type: none"> Turn the main switch off and on. Check if the stapler rotation motor connector is correctly connected. Replace the stapler rotation motor. 	B
SC 729	Two-tray finisher punch motor error	The punch home position is not detected within 250 ms after the punch clutch turns on.	<ul style="list-style-type: none"> Loose connection Defective punch H.P. sensor Defective punch clutch Defective punch hole motor 		<ol style="list-style-type: none"> Turn the main switch off and on. Check if the connectors of sensor, clutch and/or motor are correctly connected. Replace the punch H.P. sensor. Replace the punch clutch. Replace the punch hole motor. 	B
SC 730	Two-tray finisher stapler motor error	The stapler home position is not detected within a specified time after the staple motor turns on.	<ul style="list-style-type: none"> Loose connection Defective stapler H.P. sensor Defective stapler motor 		<ol style="list-style-type: none"> Turn the main switch off and on. Check if the connectors of the sensor and motor are correctly connected. Replace the stapler H.P. sensor. Replace the stapler motor. 	B

SC No.	Item	Definition	Possible Cause	Related SCs	Troubleshooting Procedure	Type
SC 731	Two-tray finisher exit guide plate motor error	The exit guide plate open sensor is not activated within a specified time after the exit guide plate motor turns on.	<ul style="list-style-type: none"> Loose connection Defective exit guide plate open sensor Defective exit guide plate motor 		<ol style="list-style-type: none"> Turn the main switch off and on. Check if the connectors of the sensor and motor are correctly connected. Replace the exit guide plate open sensor. Replace the exit guide plate motor. 	B
SC 732	Two-tray finisher tray 1 shift motor error	Tray 1 home position is not detected within a specified time after the tray 1 shift motor turns on.	<ul style="list-style-type: none"> Loose connection Defective tray shift 1 sensor Defective tray 1 shift motor 		<ol style="list-style-type: none"> Turn the main switch off and on. Check if the connectors of the sensor and motor are correctly connected. Replace the tray shift 1 sensor. Replace the tray 1 shift motor. 	B
SC 733	Two-tray finisher tray 2 lift motor error	<ul style="list-style-type: none"> The lower stack height 1 sensor is activated consecutively (detecting paper) for 15 seconds after the shift tray starts moving up. The lower stack height sensor 1 is deactivated consecutively (not detecting paper) for 15 seconds after the shift tray starts moving down. 	<ul style="list-style-type: none"> Loose connection Defective lower stack height 1 sensor Defective tray 2 lift motor Motor overload 		<ol style="list-style-type: none"> Turn the main switch off and on. Check if the connectors of the sensor and motor are correctly connected. Replace the lower stack height 1 sensor. Replace the tray 2 lift motor. 	B
SC 734	Two-tray finisher tray 2 shift motor error	Tray 2 home position is not detected within a specified time after the tray 2 shift motor turns on.	<ul style="list-style-type: none"> Loose connection Defective tray shift 2 sensor Defective tray 2 shift motor 		<ol style="list-style-type: none"> Turn the main switch off and on. Check if the connectors of the sensor and motor are correctly connected. Replace the tray shift 2 sensor. Replace the tray 2 shift motor. 	B

SC No.	Item	Definition	Possible Cause	Related SCs	Troubleshooting Procedure	Type
SC 740	Booklet finisher transport motor error	<ul style="list-style-type: none"> The folder home position sensor does not turn off within 2 seconds after the folder rollers start to move. The folder home position sensor does not turn on within 2 seconds after the folder rollers start transporting the paper to the booklet tray. 	<ul style="list-style-type: none"> Defective transport motor Loose connection of the transport motor Defective folder home position sensor Loose connection of the holder home position sensor 		<ol style="list-style-type: none"> Turn the main switch off and on. Check the connection of the transport motor. Check the connection of the folder home position sensor. Replace the transport motor. 	B
SC 741	Booklet finisher paddle motor error	<ul style="list-style-type: none"> The paddle home position sensor does not turn off within 2 seconds after the paddles start to move. The paddle home position sensor does not turn on within 2 seconds after the paddles start to operate. The stack-tray upper roller home position sensor does not turn off within 2 seconds after the paddle motor starts to lower the roller. The stack-tray upper-roller home-position sensor does not turn on with in 2 seconds after the paddle motor starts to lower the roller. 	<ul style="list-style-type: none"> Defective paddle motor Loose connection of the paddle motor Defective paddle home position sensor Loose connection of the paddle home position sensor Defective stack-tray upper-roller home-position sensor Loose connection of the stack-tray upper-roller home-position sensor 		<ol style="list-style-type: none"> Turn the main switch off and on. Check that the connection of the paddle motor. Check the connection of the paddle home position sensor. Check the connection of the stack-tray upper-roller home-position sensor. Replace the paddle motor. 	B

SC No.	Item	Definition	Possible Cause	Related SCs	Troubleshooting Procedure	Type
SC 742	Booklet finisher stapler slide motor error	<ul style="list-style-type: none"> The stapler home position sensor does not turn off within 1 second after this same sensor turns on. The stapler home position sensor does not turn on within 1 second when the stapler is coming back to its home position. 	<ul style="list-style-type: none"> Defective stapler slide motor Loose connection of the stapler slide motor Defective stapler home position sensor Loose connection of the stapler home position sensor 		<ol style="list-style-type: none"> Turn the main switch off and on. Check the connection of the stapler slide motor. Check the connection of the stapler home position sensor. Replace the stapler home position sensor. Replace the stapler slide motor. 	B
SC 743	Booklet finisher front jogger fence motor error	<ul style="list-style-type: none"> The front-jogger-fence home-position sensor does not turn off within 3 seconds after the front-jogger-fence motor starts. The front-jogger-fence home-position sensor does not turn on within 3 seconds when the front-jogger-fence motor is driving the fence to its home position. 	<ul style="list-style-type: none"> Incorrect assembling of the front jogger fence Loose connection of the front jogger fence motor Defective front-jogger-fence home-position sensor Loose connection of the front-jogger-fence home-position sensor 		<ol style="list-style-type: none"> Turn the main switch off and on. Check the connection of the front jogger fence motor. Check the connection of the front-jogger-fence home-position sensor. Replace the front-jogger-fence home-position sensor. Replace the front jogger fence motor. 	B
SC 744	Booklet finisher rear jogger fence motor error	<ul style="list-style-type: none"> The rear-jogger-fence home-position sensor does not turn off within 3 seconds after the rear-jogger-fence motor starts. The rear-jogger-fence home-position sensor does not turn on within 3 seconds when the rear-jogger-fence motor is driving the fence to its home position. 	<ul style="list-style-type: none"> Incorrect assembling of the rear jogger fence Loose connection of the rear jogger fence motor Defective rear-jogger-fence home-position sensor Loose connection of the rear-jogger-fence home-position sensor 		<ol style="list-style-type: none"> Turn the main switch off and on. Check the connection of the rear jogger fence motor. Check the connection of the rear-jogger-fence home-position sensor. Replace the rear-jogger-fence home-position sensor. Replace the rear jogger fence motor. 	B

SC No.	Item	Definition	Possible Cause	Related SCs	Troubleshooting Procedure	Type
SC 745	Booklet finisher stack-tray exit motor error	<ul style="list-style-type: none"> • The stack-tray-belt home-position sensor does not turn off within 394 milliseconds after the stack-tray exit roller starts to drive the belts. → The stack-tray exit motor retries to drive the belts, but the stack-tray-belt home-position sensor still does not turn off within another 394 milliseconds. • The stack-tray-belt home-position sensor does not turn on within 1,084 milliseconds after the same home-position sensor turns off. → The stack-tray exit motor retries to drive the belts, but the stack-tray belt home-position sensor still does not turn on within another 1,084 milliseconds. 	<ul style="list-style-type: none"> • Defective stack-tray exit motor • Loose connection of the stack-tray exit motor • Defective stack-tray-belt home-position sensor • Loose connection of the stack-tray-belt home-position sensor 		<ol style="list-style-type: none"> 1. Turn the main switch off and on. 2. Check the connection of the stack-tray exit motor. 3. Check the connection of the stack-tray-belt home-position sensor. 4. Replace the stack-tray-belt home-position sensor. 5. Replace the stack-tray exit motor. 	B

SC No.	Item	Definition	Possible Cause	Related SCs	Troubleshooting Procedure	Type
SC 746	Booklet finisher stapler/folder motor error	<ul style="list-style-type: none"> • The stapler/folder motor starts. However, the controller does not receive the signal from the encoder sensor within 0.1 second. • The stapler/folder motor starts to drive the stapler unit, and the stapler switch is on. However, the controller does not receive the signal from the home position sensor for 0.5 second. • The stapler starts to staple the paper. However, the controller does not receive any signal from the home position sensor, and the stapler switch is off. • The stapler/folder motor starts to drive the folder rollers. However, the home position sensor does not turn off within 9.247 seconds. • The home position sensor does not turn on within 9.247 seconds after this same sensor turns off. 	<ul style="list-style-type: none"> • Malfunction of the stapler/folder motor • Loose connection of the stapler/folder motor • Loose connection of the encoder sensor • Defective encoder sensor • Loose connection of the stapler switch • Defective stapler switch • Loose connection of the stapler home position sensor • Defective stapler home position sensor • Loose connection of the folder-roller home-position sensor • Defective folder-roller home-position sensor 		<ol style="list-style-type: none"> 1. Turn the main switch off and on. 2. Check the connection of the stapler/folder motor. 3. Check the connection of the encoder sensor. 4. Check the connection of the stapler switch. 5. Check the connection of the stapler home position sensor. 6. Check the connection of the folder-roller home-position sensor. 7. Replace the stapler/folder motor. 8. Replace the encoder sensor. 9. Replace the stapler switch. 10. Replace the stapler home position sensor. 11. Replace the folder-roller home-position sensor. 	B

SC No.	Item	Definition	Possible Cause	Related SCs	Troubleshooting Procedure	Type
SC 747	Booklet finisher lift motor error	<ul style="list-style-type: none"> The upper limit sensor detects the regular tray while the lift motor is lifting the regular tray. The paper height sensor does not turn off within 10 seconds after the lift motor starts to lower the regular tray. The upper limit sensor does not turn off within 10 seconds after the lift motor starts to lower the regular tray. The paper height sensor does not turn on within 10 seconds after the lift motor starts to lift the regular tray. The controller does not receive the signal from the lift motor encoder sensor within 50 milliseconds after the lift motor starts. 	<ul style="list-style-type: none"> Defective paper height sensor Loose connection of the paper height sensor Defective upper limit sensor Loose connection of the upper limit sensor Defective lift motor Loose connection of the lift motor Incorrect assembling of the lift motor Defective lift motor encoder sensor Loose connection of the lift motor encoder sensor 		<ol style="list-style-type: none"> Turn the main switch off and on. Check the connection of the paper height sensor. Check the connection of the upper limit sensor. Check the connection of the lift motor encoder sensor. Check the connection of the lift motor. Replace the paper height sensor. Replace the upper limit sensor. Replace the lift motor encoder sensor. Replace the lift motor. 	B
SC 748	Booklet finisher backup data error	The CPU tries to write data in the EEPROM three times, but fails to write data.	<ul style="list-style-type: none"> Defective EEPROM EEPROM not installed 		<ol style="list-style-type: none"> Turn the main switch off and on. Check that the EEPROM is installed. Replace the EEPROM. 	B
SC 749	Booklet finisher punch-unit communication error	A communication-error alarm is not cleared for 3 seconds.	<ul style="list-style-type: none"> The finisher controller cannot communicate with the punch-unit controller. 		<ol style="list-style-type: none"> Turn the main switch off and on. Check the connection between the finisher controller and the punch-unit controller. 	B
SC 750	Booklet finisher punch-unit controller error	The checksum in the backup data is inconsistent.	<ul style="list-style-type: none"> Defective EEPROM (on the punch-unit controller) EEPROM not installed 		<ol style="list-style-type: none"> Turn the main switch off and on. Check that the EEPROM is installed. Replace the EEPROM. 	B

SC No.	Item	Definition	Possible Cause	Related SCs	Troubleshooting Procedure	Type
SC 751	Booklet finisher punch-unit sensor error 1	The paper edge and size sensors receive the 2.5-volt light or weaker light even when the source emits 4.4-volt light.	<ul style="list-style-type: none"> Defective sensors Dirty sensors 		<ol style="list-style-type: none"> Turn the main switch off and on. Clean the sensors. Replace the sensors. 	B
SC 752	Booklet finisher punch-unit registration motor error	<ul style="list-style-type: none"> The registration motor drives the slide unit to the rear side for 1 second. However, the home position sensor does not turn on. The registration motor drives the slide unit to the front side for 1 second. However, the home position sensor does not turn off. 	<ul style="list-style-type: none"> Incorrect assembly of the registration motor Loose connection of the registration motor Defective home position sensor Loose connection of the home position sensor 		<ol style="list-style-type: none"> Turn the main switch off and on. Check the connection of the registration motor. Check the connection of the home position sensor. Replace the home position sensor. Replace the registration motor. 	B
SC 753	Booklet finisher punch-unit punch motor error	<ul style="list-style-type: none"> The punch motor starts to drive the punch cams. However, the controller does not receive the encoder-lock signal for 60 milliseconds. The punch motor start to drive the punch cams. However, the home positions sensor does not turn on for 250 milliseconds. 	<ul style="list-style-type: none"> Malfunction of the punch motor Loose connection of the punch motor Defective home position sensor Loose connection of the home position sensor Loose connection of the encoder sensor Defective encoder sensor 		<ol style="list-style-type: none"> Turn the main switch off and on. Check that the connection of the punch motor. Check the connection of the home position sensor. Check the connection of the encoder sensor. Replace the home position sensor. Replace the encoder sensor. Replace the punch motor. 	B
SC 754	Booklet finisher punch-unit sensor error 2	The A/D inputs of the sensor are not corrected by varying the D/A outputs.	<ul style="list-style-type: none"> Defective sensor Dirty sensor 		<ol style="list-style-type: none"> Turn the main switch off and on. Clean the sensors. Replace the sensors. 	B

SC No.	Item	Definition	Possible Cause	Related SCs	Troubleshooting Procedure	Type
SC 817	Monitor error	<ul style="list-style-type: none"> When the boot loader cannot read the diagnostic module, kernel or route file system. When the boot loader fails to check the signature for the diagnostic module, kernel or route file system. 	<ul style="list-style-type: none"> Defective file of the diagnostic module, kernel or route file system The file of the diagnostic module, kernel or route file system does not exist. The file of the diagnostic module, kernel or route file system in the SD card is falsified. 		<ol style="list-style-type: none"> Update the controller system ROM. Use the authorized SD card for booting. 	C
SC 818	Watch-dog error	While the system program is running, other processes do not operate at all.	<ul style="list-style-type: none"> Defective controller Software error 		<ol style="list-style-type: none"> Turn the main switch off and on. Replace the controller. See NOTE 1 at the end of the SC table 	CTL
SC 819	Fatal error					
[696E]	Process error	System completely down	<ul style="list-style-type: none"> Defective RAM DIMM Defective Flash ROM Defective controller Software error 		<ol style="list-style-type: none"> Turn the main switch off and on. Check and/or replace the RAM DIMM. Replace the controller. See NOTE at the end of the SC table. 	CTL
[766D]	Memory error	Unexpected system memory size				
[4361]	Kernel stop error	The cache error trap occurs in the CPU.	<ul style="list-style-type: none"> CPU cache error 		<ol style="list-style-type: none"> Replace the controller. 	CTL
	Kernel stop error	Any error in the operation system (An error message is output.)	<ul style="list-style-type: none"> Defective CPU Defective memory Defective flash memory Incorrect software 		<ol style="list-style-type: none"> Replace the memory. Replace the controller. 	CTL



SC No.	Item	Definition	Possible Cause	Related SCs	Troubleshooting Procedure	Type
SC 821	Self-diagnostics error: ASIC [XXXX]: Detailed error code					
[0B00]	ASIC error	The write-&-verify check error has occurred in the ASIC.	<ul style="list-style-type: none"> Defective ASIC device 		1. Replace the controller.	CTL
[0B06]	ASIC not detected	The ASIC is not detected.	<ul style="list-style-type: none"> Defective ASIC Poor connection between North Bridge and PCI I/F 		1. Replace the controller.	CTL
[0B10]	SHM register check error	<ul style="list-style-type: none"> The register test error of the connection bus occurs. Data in SHM register is incorrect. 	<ul style="list-style-type: none"> Defective connection bus Abnormal SHM 		1. Replace the controller.	CTL
SC 822	Self-diagnostic error: HDD (Hard Disk Drive) [XXXX]: Detailed error code					
[3003]	Timeout error	When the main switch is turned on or starting the self-diagnostic, the HDD stays busy for the specified time or more.	<ul style="list-style-type: none"> Loose connection Defective HDD Defective controller device 		<ol style="list-style-type: none"> Turn the main switch off and on. Check that the HDD is correctly connected to the controller. Replace the HDD. Replace the controller. 	CTL
[3004]	Command error					
[3013]	Timeout error 2	<ul style="list-style-type: none"> Mandolin does not respond. The HDD device remains BUSY for more than 31 s. The BUSY signal does not drop within 6 s after the diagnostic command is issued to the HDDs. 				
[3014]	Command error 2	<ul style="list-style-type: none"> Error returned from HDD in response to the self-diagnostic command. Mandolin could not be located due to a read/write error at the HDD register. 				

SC No.	Item	Definition	Possible Cause	Related SCs	Troubleshooting Procedure	Type
SC 823	Self-diagnostic error: NIB [XXXX]: Detailed error code					
[6101]	MAC address check sum error	The result of the MAC address check sum does not match the check sum stored in ROM.	<ul style="list-style-type: none"> Defective controller 		<ol style="list-style-type: none"> Turn the main switch off and on. Replace the controller. 	CTL
[6104]	PHY IC error	The PHY IC on the controller cannot be correctly recognized.				
[6105]	PHY IC loop-back error	An error occurred during the loop-back test for the PHY IC on the controller.				
SC 824 [1401]	Self-diagnosis error: Standard NVRAM	The controller cannot recognize the standard NVRAM installed or detects that the NVRAM is defective.	<ul style="list-style-type: none"> Loose connection Defective standard NVRAM Defective controller 		<ol style="list-style-type: none"> Turn the main switch off and on. Check the standard NVRAM is firmly inserted into the socket. Replace the NVRAM. Replace the controller. 	CTL
SC 826	Self-diagnostic error: RTC [XXXX]: Detailed error code					
[15FE]	RTC backup battery error	The RTC Battery voltage is exhausted or not within rated specification.	<ul style="list-style-type: none"> Backup battery discharged 		<ol style="list-style-type: none"> Turn the main switch off and on. Replace the RTC backup battery. 	CTL
SC 828	Self-diagnostic error: Flash ROM [XXXX]: Detailed error code					
[0101]	Check sum error 1	The boot monitor and OS program stored in the Flash ROM is checked. If the check sum of the program is incorrect, this SC code is displayed.	<ul style="list-style-type: none"> Defective Flash ROM Defective controller 		<ol style="list-style-type: none"> Turn the main switch on and off. Replace the controller. 	CTL

SC No.	Item	Definition	Possible Cause	Related SCs	Troubleshooting Procedure	Type
SC 833	Self-diagnosis error: Engine I/F ASIC [XXXX]: Detailed error code					
[0F30]	ASIC detection error	The ASIC for the system control is not detected. After the PCI configuration, the device ID for the ASIC could not be checked.	<ul style="list-style-type: none"> Defective ASIC for system control Defective North Bridge and AGPI/F 		<ol style="list-style-type: none"> Turn the main switch off and on. Replace the motherboard. 	CTL
[0F31]	ASIC register error	The register test error of the engine control ASIC occurs.				
[0F41]	Resident memory verification error	The resident RAM test error is detected.				
[50B1]	Clock generator detection error	The initialization and read for the connection bus fail.	<ul style="list-style-type: none"> Defective connection bus Abnormal SSCG 		<ol style="list-style-type: none"> Turn the main switch off and on. Replace the motherboard. 	CTL
[50B2]	Clock generator verification error	SSCG register value does not match the default value.				
SC 834	Self-diagnostic error: Optional Memory error	The optional RAM test error is detected.	<ul style="list-style-type: none"> Defective memory device 		<ol style="list-style-type: none"> Turn the main switch off and on. Replace the motherboard. 	
SC 850	Network interface error	The network is unusable.	<ul style="list-style-type: none"> Defective controller 		<ol style="list-style-type: none"> Turn the main switch off and on. Replace the controller. 	CTL
SC 851	IEEE1394 interface error	The 1394 interface is unusable.	<ul style="list-style-type: none"> Defective IEEE1394 Defective controller 		<ol style="list-style-type: none"> Turn the main switch off and on. Replace the IEEE1394 interface board. Replace the controller. 	CTL
SC 853	Wireless LAN card not detected	The wireless LAN card is not detected before communication is established, though the wireless LAN board is detected.	<ul style="list-style-type: none"> Loose connection 	SC 854	<ol style="list-style-type: none"> Check the connection. 	CTL

SC No.	Item	Definition	Possible Cause	Related SCs	Troubleshooting Procedure	Type
SC 854	Wireless LAN card not detected	The wireless LAN card is not detected after communication is established, though the wireless LAN board is detected.	<ul style="list-style-type: none"> Loose connection 	SC 853	1. Check the connection.	CTL
SC 855	Wireless LAN card error	An error is detected in the wireless LAN card.	<ul style="list-style-type: none"> Loose connection Defective wireless LAN card 		1. Check the connection. 2. Replace the wireless LAN card.	CTL
SC 856	Wireless LAN card error	An error is detected in the wireless LAN board.	<ul style="list-style-type: none"> Defective wireless LAN board Loose connection 		1. Check the connection. 2. Replace the wireless LAN board.	CTL
SC 857	USB interface error	The USB interface cannot be used due to a driver error.	<ul style="list-style-type: none"> Defective USB driver Loose connection 		1. Check the connection. 2. Replace the USB board.	CTL
SC 860	HDD: Initialization error	The controller detects that the hard disk fails.	<ul style="list-style-type: none"> HDD not initialized Defective HDD 		1. Turn the main switch off and on. 2. Reformat the HDD. 3. Replace the HDD.	CTL
SC 861	HDD: Reboot error	The HDD does not become ready within 30 seconds after the power is supplied to the HDD.	<ul style="list-style-type: none"> Loose connection Defective cables Defective HDD Defective controller 		1. Turn the main switch off and on. 2. Check the connection between the HDD and controller. 3. Check and replace the cables. 4. Replace the HDD. 5. Replace the controller.	CTL
SC 863	HDD: Read error	The data stored in the HDD cannot be read correctly.	<ul style="list-style-type: none"> Defective HDD Defective controller 		1. Turn the main switch off and on. 2. Replace the HDD. 3. Replace the controller.	CTL
SC 864	HDD: CRC error	While reading data from the HDD or storing data in the HDD, data transmission fails.	<ul style="list-style-type: none"> Defective HDD 		1. Turn the main switch off and on. 2. Replace the HDD.	CTL
SC 865	HDD: Access error	An error is detected while operating the HDD.	<ul style="list-style-type: none"> Defective HDD 		1. Turn the main switch off and on. 2. Replace the HDD.	CTL
SC 866	SD card authentication error	A correct license is not found in the SD card.	<ul style="list-style-type: none"> SD-card data has corrupted. 		1. Store correct data in the SD card.	CTL

SC No.	Item	Definition	Possible Cause	Related SCs	Troubleshooting Procedure	Type
SC 867	SD card error	The SD card is ejected from the slot.	<ul style="list-style-type: none"> The SD card is ejected from the slot. 		<ol style="list-style-type: none"> 1. Install the SD card. 2. Turn the main switch off and on. 	CTL
SC 868	SD card access error 243-252: File system error 253: Device error	An error report is sent from the SD card reader.	<ul style="list-style-type: none"> An error is detected in the SD card. 		<ol style="list-style-type: none"> 1. For a file system error, format the SD card on your PC. 2. For a device error, turn the mains switch off and on. 3. Replace the SD card. 4. Replace the controller. 	CTL
SC 870	Address book error	An error is detected in the data copied to the address book over a network.	<ul style="list-style-type: none"> Defective software program Defective HDD Incorrect path to the server 		<ol style="list-style-type: none"> 1. Turn the main switch off and on. 2. Initialize the address book data (SP5-846-050). 3. Replace the HDD. 	CTL
SC 872	HDD mail data error	An error is detected in the HDD at machine initialization.	<ul style="list-style-type: none"> Defective HDD Power failure during an access to the HDD 		<ol style="list-style-type: none"> 1. Turn the main switch off and on. 2. Replace the HDD. 	CTL
SC 873	HDD mail transfer error	An error is detected in the HDD at machine initialization.	<ul style="list-style-type: none"> Defective HDD Power failure during an access to the HDD 		<ol style="list-style-type: none"> 1. Turn the main switch off and on. 2. Replace the HDD. 	CTL
SC 874	Delete All error 1: HDD	An error of the deleting all data for the HDD/NVRAM is detected after the data overwriting function has been executed.	<ul style="list-style-type: none"> Defective HDD No SD card 		<ol style="list-style-type: none"> 1. Turn the main switch off/on and try the operation again. 2. Replace the HDD. 	CTL
SC 875	Delete All error 2: Data area	An error occurs while the machine deletes data from the HDD.	<ul style="list-style-type: none"> Deleting data failure 		<ol style="list-style-type: none"> 1. Turn the main switch off/on and try the operation again. 	CTL
SC 876	Log Data Error	The log data error is detected when obtaining or referring the log data while the machine is activated, turning on the main power or logging data.	<ul style="list-style-type: none"> Log data corrupt Defective or Not installed SD card Defective software Incorrect HDD or NVRAM 		<ol style="list-style-type: none"> 1. Turn the main switch off/on and try the operation again. 2. Initialize the HDD. 3. Replace the HDD. 4. Replace the NVRAM. 5. Replace the SD card. 	CTL

SC No.	Item	Definition	Possible Cause	Related SCs	Troubleshooting Procedure	Type
SC 900	Electric counter error	Abnormal data is stored in the counters.	<ul style="list-style-type: none"> Defective NVRAM Power failure during an access to the HDD 		<ol style="list-style-type: none"> Turn the main switch off and on. Check the connection between the NVRAM and controller. Replace the NVRAM. Replace the controller. 	CTL
SC 920	Printer application error	An error is detected in the printer application program.	<ul style="list-style-type: none"> Defective software Unexpected hardware resource (e.g., memory shortage) 		<ol style="list-style-type: none"> Turn the main switch off and on. 	CTL
SC 921	Printer font error	A necessary font is not found in the SD card.	<ul style="list-style-type: none"> A necessary font is not found in the SD card. The SD card data is corrupted. 		<ol style="list-style-type: none"> Check that the SD card stores correct data. 	CTL
SC 990	Software performance error	The software makes an unexpected operation.	<ul style="list-style-type: none"> Defective software Defective controller Software error 		<ol style="list-style-type: none"> Turn the main switch off and on. Reinstall the controller and/or engine main firmware. See NOTE 1 at the end of the SC table. 	CTL
SC 991	Software continuity error	The software has attempted to perform an unexpected operation. However, unlike SC 990, the object of the error is continuity of the software.	<ul style="list-style-type: none"> Software program error Internal parameter incorrect, insufficient working memory. 		This SC is not displayed on the LCD (logging only).	CTL
SC 992	Undefined error	An undefined error has occurred.	<ul style="list-style-type: none"> Defective software program 			CTL
SC 995	BCU error	The DIP switch on the BCU is incorrectly set.	<ul style="list-style-type: none"> The DIP switch on the BCU is incorrectly set. 		<ol style="list-style-type: none"> Set the DIP switch correctly. Turn the main switch off and on. 	D

SC No.	Item	Definition	Possible Cause	Related SCs	Troubleshooting Procedure	Type
SC 998	Application start error	No applications start within 60 seconds after the power is turned on.	<ul style="list-style-type: none"> Loose connection of RAM-DIMM, ROM-DIMM Defective controller Software problem 		<ol style="list-style-type: none"> Turn the main switch off and on. Check if the RAM-DIMM and ROM-DIMM are correctly connected. Reinstall the controller system firmware. Replace the controller. 	CTL

NOTE 1: If a problem always occurs in a specific condition (for example, printer driver setting, image file), the problem may be caused by a software error. In this case, the following data and information needs to be sent back to your product specialist.

- Symptom / Possible Causes / Action taken
- Summary sheet (SP mode "Service SP", SP1-004 [Print Summary])
- SMC - All (SP5-990-001)
- SMC - Logging (SP5-990-004)
- Printer driver settings used when the problem occurs
- All data displayed on the screen (SC code, error code, and program address where the problem is logged.)
- Image file which causes the problem, if possible

4.4 TROUBLESHOOTING GUIDE 1

4.4.1 IMAGE QUALITY

Work-flow

The following work-flow shows the basic troubleshooting steps for the considerable image quality problems on this product.

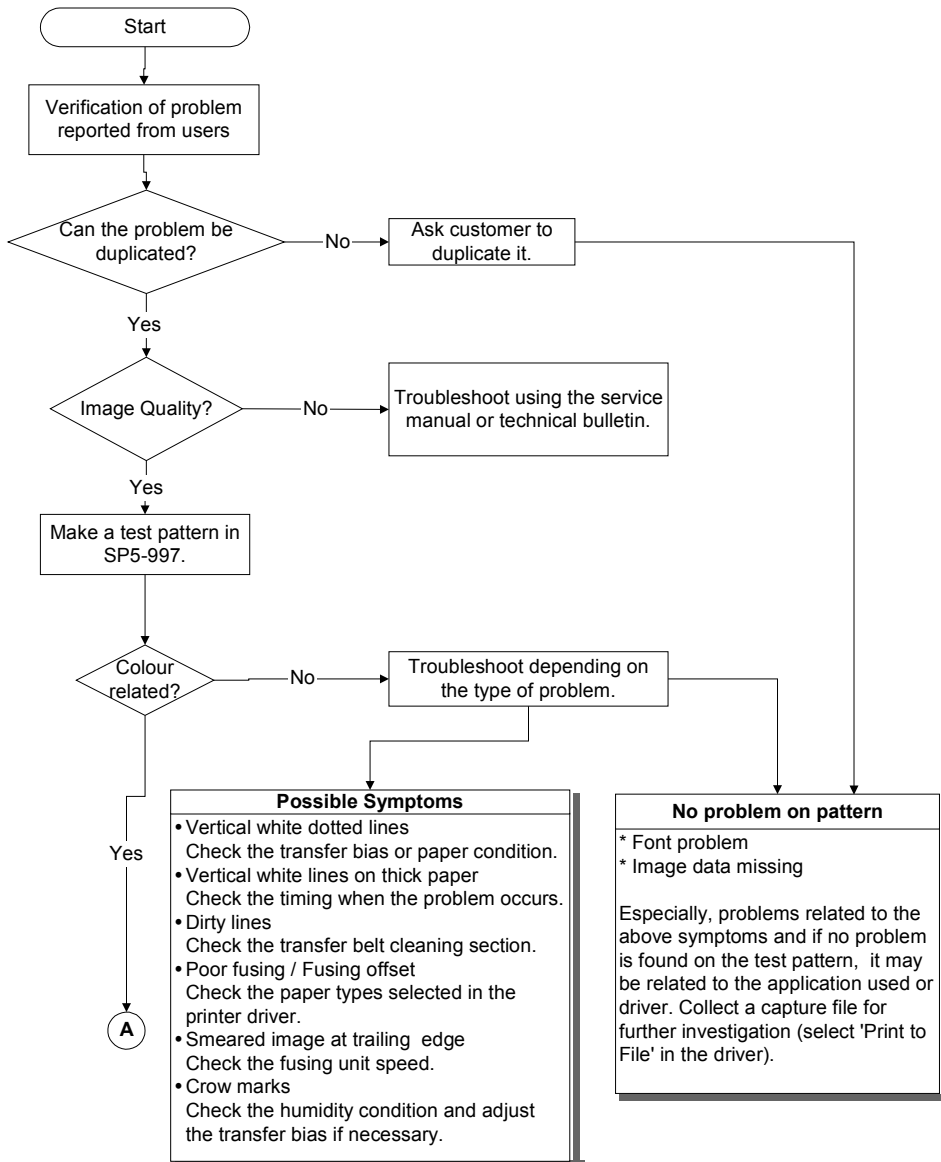

Trouble-shooting

G130T501.WMF

(From previous page)

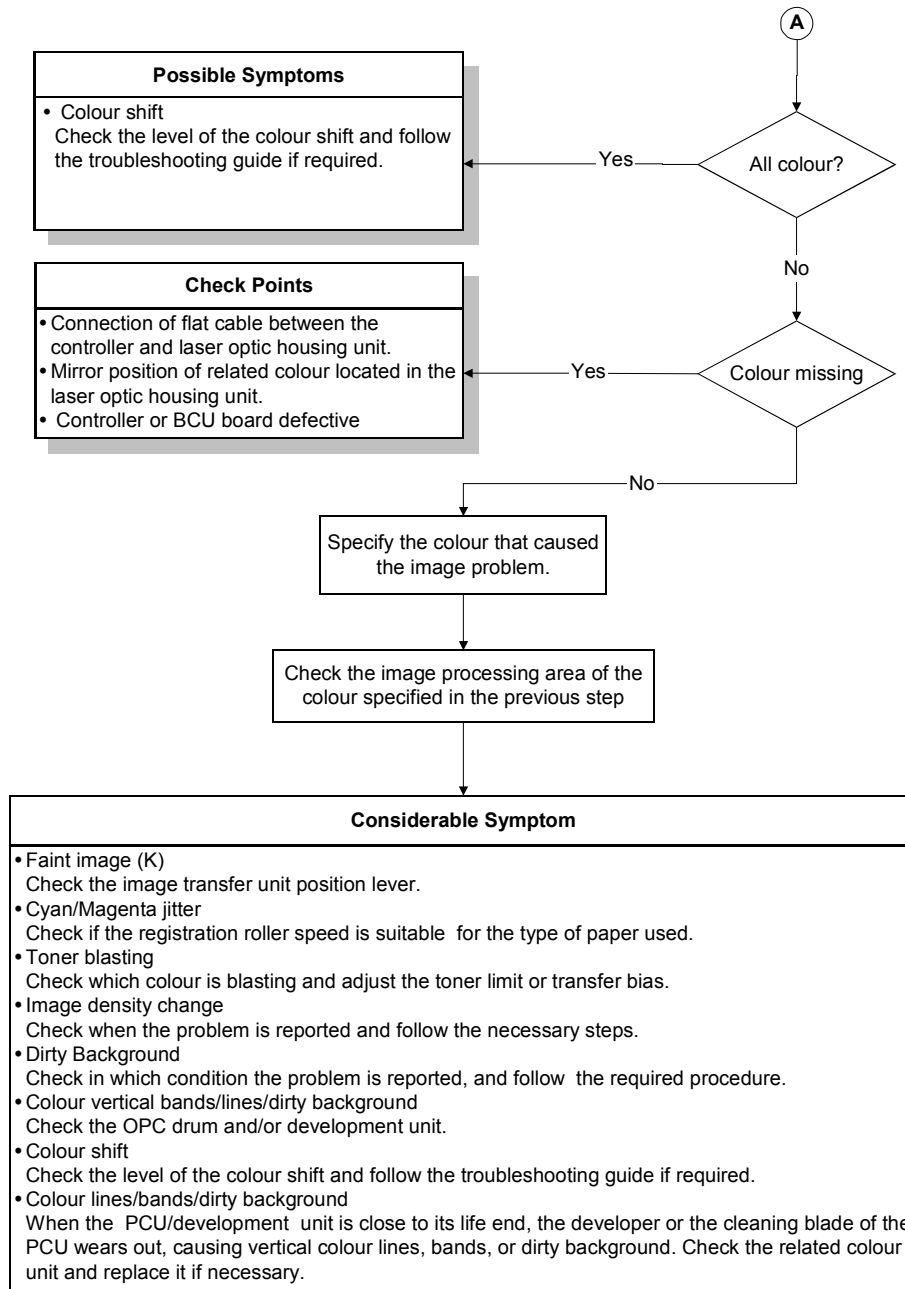

G130T502.WMFF

4.5 TROUBLESHOOTING GUIDE 2

4.5.1 IMAGE QUALITY

Detailed Explanation

The table below shows the troubleshooting procedure for the considerable image problems.

Subject	Symptom	Cause	Action
Symptoms not related to color			
Vertical white dotted lines	If the paper transfer bias is excessive for the paper type used in the low humidity condition, vertical white dotted lines may appear.	In the low humidity condition, the electrical resistance of paper tends to increase. Excessive paper transfer bias may cause electrical leak, causing vertical white lines.	<ul style="list-style-type: none"> • Check if the optional heater has been installed in the paper tray and it is activated. • Customize (decrease) the paper transfer current for the related mode (SP2-301).
Vertical white lines	In high temperature and humidity conditions, vertical white lines may appear in halftone areas on thick paper after multiple prints of the same image.	In this condition, the drum sensitivity tends to drop. Since the image transfer efficiency differs between plain and thick paper, sensitivity drop may cause changes in image transfer efficiency on thick paper, causing vertical white lines.	The drum sensitivity recovers, and this symptom disappears after waiting for about 5 minutes after this symptom has been observed.
Dirty lines/bands or background on 2nd side		The cleaning blade of the transfer belt cleaning may be worn away or damaged when the transfer belt cleaning unit becomes close to its life (500KP).	Check and replace the transfer belt-cleaning unit.
Poor fusing / Fusing offset		The type of paper selected in the printer driver does not match the paper type used for printing, causing the fusing temperature not to be controlled for the paper used.	Please instruct users to select the correct paper type in the printer driver.

Subject	Symptom	Cause	Action
Smearred image	When making prints of an original with a solid image near the trailing, a smearred image may appear.	The paper's trailing edge tends to flip up and come very close to the fusing belt after it passes the paper transfer unit. The static electricity built up on the fusing belt may cause toner to move, resulting in the smearred image. This is most noticeeable with 600x600dpi printing.	Please instruct users to select 1800x600 or 1200x1200dpi.
Crow marks	When making duplex prints in low temperature and humidity conditions, crow marks may appear on black images, especially in halftone areas on the 2nd side.	A charge is applied to the paper at each color station in order to attract each toner onto the paper. Therefore, the initial toner colors will receive multiple charging as they pass each station, which increases the attractive force between the toner and paper. Since black is the last toner to be applied, the attractive force between it and the paper is lowest. Black toner moves on the paper during transport to the fusing section, due to discharge from the toner to the surrounding guide plates.	Using SP2-301 (Transfer Current), increase the paper transfer current for black in the mode in which the problem occurs. NOTE: White dotted lines may appear on outputs if the transfer current is increased too much. Therefore, after adjusting the transfer current, it is necessary to check the results by making a solid or halftone image in duplex mode.

Subject	Symptom	Cause	Action
Symptoms related to color			
Faint image (black)	Only black becomes lighter.	The transfer belt position is not in the correct position.	Check the transfer belt unit position and/or the transfer belt unit release lever.
Magenta and/or cyan jitter	Magenta jitter may appear at 81 mm and/or cyan jitter at 162/ 125 mm from the trailing edge.	<p>If the registration roller speed is too fast for the paper types used, the shock when the trailing edge has just passed the registration roller generates vibration, causing the jitter.</p> <p>This may appear especially when using thick paper because of its stiffness.</p>	<p>Adjust the registration roller speed depending on the paper types and/or mode selected.</p> <p>SP1-004-4: Normal paper (1200 dpi) SP1-004-5: Normal paper (600 dpi) SP1-005-3: Thick paper (1200 dpi)</p> <p>If SP1-005-3 cannot improve the level even when setting it to "-1.0", follow the procedure below.</p> <ol style="list-style-type: none"> 1. Set SP1-005-3 to "-1.0". 2. Print the samples by adjusting SP1-004-4 from 100% (-0.2% to -0.8%). After adjusting SP1-004-4, check the image quality also with normal paper in the 1200 dpi mode. Readjust it so that the image quality level is acceptable for both thick and normal paper if necessary.
Toner blasting (1)	Toner may blast, causing smeared text characters and/or lines in 2C or process black mode (depending on the PDL setting or type of paper used.)	An excessive amount of toner is used for development.	<p>Change the toner limit setting in SP mode.</p> <ul style="list-style-type: none"> • If toner blasted images appear for text or lines in 2C, decrease the setting for Text from 190% to 150 - 170%. • If toner blasted images for text and lines recognized as pure image data (i.e. not processed as text/line data), decrease the setting for Photo from 260% to 170 - 190%. <p>NOTE: If the toner limit is lowered too much, it may cause the density of shadow areas to be not smooth.</p>

Subject	Symptom	Cause	Action
Toner blasting (2)-1	Black toner may blast on the 1st side of paper under the low temperature at B&W print mode.	Black toner moves on the paper during transport to the fusing section, due to discharge from the toner to the surrounding guide plates.	Decrease the image density for Black with UP mode. Change the "0" to "-1" with UP mode (Maintenance > Image > Black)
Toner blasting (2)-2	Black toner may blast on the 1st side of paper under the low temperature at color print mode.	Black toner moves on the paper during transport to the fusing section, due to discharge from the toner to the surrounding guide plates.	Decrease the paper transfer current in SP data from the default setting to a recommended value depending on the mode selected as shown below. SP2-301-013, -015, -017 ([FC Y/M/C] Low speed): "10" to "8" SP2-301-014, -016, -018 ([FC Y/M/C] Middle speed): "16" to "13" (G130) "21" to "17" (G131) (If you want to improve this only at 600 dpi print mode, change the values with only SP2-301-014, -016 and -018.) NOTE: If the toner limit is lowered too much, it may cause the density of shadow areas to be not smooth.
Toner blasting (2)-3	Black toner may blast on the 2nd side of paper under the low temperature at B&W print mode.	Black toner moves on the paper during transport to the fusing section, due to discharge from the toner to the surrounding guide plates.	Increase the paper transfer current in SP data from the default setting to a recommended value depending on the mode selected as shown below. SP2-301-004 ([K] Low speed): "10" to "14" SP2-301-005 ([K] Middle speed): "21" to "27" (G131) SP2-301-006 ([K] High speed): "21" to "27" (G130) (If you want to improve this only at 600 dpi print mode, change the only values with SP2-301-005 and -006.) NOTE: If the toner limit is heightened too much, it may cause image offset.

Subject	Symptom	Cause	Action
Toner blasting (2)-4	Black toner may blast on the 2nd side of paper under the low temperature at color print mode.	Black toner moves on the paper during transport to the fusing section, due to discharge from the toner to the surrounding guide plates.	<p>Decrease the paper transfer current and paper attraction roller current in SP data from the default setting to a recommended value depending on the mode selected as shown below.</p> <p>SP2-301-021, -023, -025 ([FC Y/M/C] Low speed): "9" to "6 ~ 7"</p> <p>SP2-301-022, -024, -026 ([FC Y/M/C] Middle speed): "12" to "9 ~ 10" (G130) "16" to "12 ~ 13" (G131)</p> <p>SP2-801-010 ([FC] Low speed): "5" to "8" SP2-801-011 ([FC] Middle speed): "8" to "12" (G130) "10" to "15" (G131)</p> <p>(If you want to improve this only at 600 dpi print mode, change the only values with SP2-301-022, -024, -026 and SP2-801-011.)</p> <p>NOTE: If the toner limit is lowered too much, it may cause the density of shadow areas to be not smooth.</p>
Symptoms related to color			
Color Shift	Color shift level is out of the adjustment standard.	The adjustment standard on this product is "maximum 150 μm". The color shift level may change depending on a type of paper used.	Check the level of the color shifts reported from user and follow the troubleshooting procedure described in section 4- if necessary.
Color missing	Color(s) is missing on the outputs.	The position of 3rd mirror moves due to the rough transportation of service part; and then, becomes out of position. Flat cable(s) is not correctly connected to the BCU board.	<ul style="list-style-type: none"> • When replacing the laser optic housing unit due to any reason, make a color demo page in the UP mode. If color(s) is missing, open the unit and reposition the mirror(s). • Reconnect the flat cable(s) firmly.

Subject	Symptom	Cause	Action
Symptoms related to color			
Image density change (1)	When the machine is tuned on in the morning (having been unused for a while), the ID of the initial outputs may be relatively low or high, in which case the machine needs to compensate by raising or lowering the ID during machine operation.	When the machine is off, the environmental conditions can begin to affect the machine's development capability. When the main switch is tuned on, the machine starts a process control self-check and adjusts the development parameters to achieve the proper development potential gap without adjusting the toner concentration. Over the course of the print operation, the ID will then get closer and closer to the target level.	If this is often pointed out by users who are very particular about image density, turn on Auto TD Adjustment (SP3-125-003) as a solution. NOTE: It takes about 5 minutes to complete the self-check.
Image density change (2)	Image density is too low or high.	If the machine has never been turned off and Energy Saver 2 (Auto Off mode) is disabled, the machine has never performed the initial process control self-check, causing the image density to become low or high.	Change the settings of the following SP modes: SP3-906-003 Non-use Time 1 0 (Default) to 999 SP3-906-004 Non-use Time 2 0 to 2550 (Default: 480) <ul style="list-style-type: none">• If Energy Saver 1 is activated (Default: Off), the non-use time process control self-check will not function. Therefore, make sure that Energy Saver 1 is Off (UP mode).• With the above setting, the self-check automatically starts after 500 prints and after no prints have been made for 480 minutes (8 hours). Based on the average daily printing volume of 500 prints, self-check would be performed first thing every morning. These settings are suitable for machines, which are used during the day and then kept On in Ready status throughout the night. Therefore, this SP mode should be set based on the particular way the customer uses the printer.

4.5.2 COLOR SHIFT

The following briefly explain the factors causing color shifts and what to do on the machine to correct it:

- Temperature change causes the optical components in the laser optics housing unit to contract, causing the main scan magnification to change. To correct the line position, the machine automatically does the line position adjustment when the temperature changes by 5°C since the last position adjustment. If the line position adjustment functions correctly, no color shift occurs. If the line position adjustment fails (result: SP5-993-007), color lines may shift anywhere on the outputs.
- The process speed at each stage (registration roller, transfer belt, and fusing belt/roller) affects the paper transport speed. If the paper transport speed changes during image transfer of a color, the color line being transferred shifts with respect to the color line already transferred to the paper. The registration roller speed (adjusted by color development motor speed) and fusing belt/roller speed (adjusted by black development motor speed) are adjusted by the manufacturer. Paper speed may slightly change due to the type of paper used or after replacing the parts related to the drive sections of the registration section, transport unit, and fusing unit. (After replacing the fusing unit, the speed adjustment should be done in the User Program mode.) Also, the position where color shift occurs depends on which section starts moving at the incorrect speed.
- Paper skew directly affects the color shift between the front and rear sides. There are several factors. One of them is the position of the side fences.

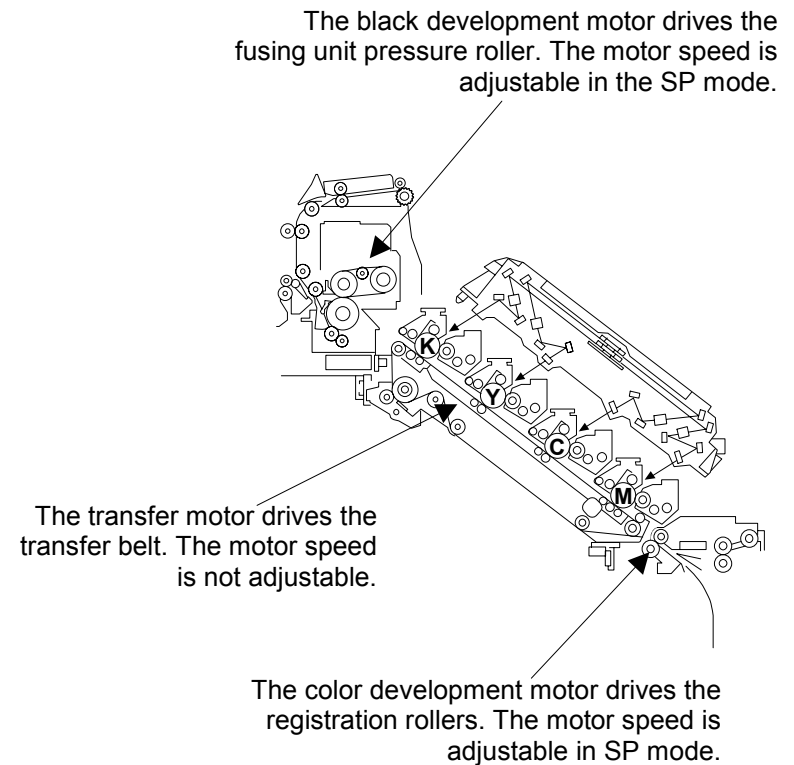

G130T505.WMFF

As explained on the previous page, there are several types of color shift problem. The following table shows the symptoms, factors, action required, and the page to see for details.

	Symptom	Factors	Action Required	Refer to #
1	Color shift on entire image in main-scan and/or sub-scan directions	<ul style="list-style-type: none"> • Line position adjustment does not function correctly. • Transfer belt unit has just been replaced. 	<ul style="list-style-type: none"> • Check the result of the line position adjustment (SP5-993-007) and solve the problem if an error was detected. • Check which color lines are shifted from black line and adjust the SP modes for registration and magnification. 	
2	Color shifts only at the leading edge area (sometimes causing shock jitter, magenta or cyan lines)	Registration roller speed is not appropriate.	Adjust the color development motor speed (SP1-004-4, 5, and SP1-005-003) depending on the process speed.	
3	Color shifts only at the trailing edge area	Fusing belt/roller speed is not appropriate.	Adjust the black development motor speed (SP1-004-001, 002, and 007, or "Fuser Adjust" in the User Program mode) depending on the process speed.	
4	Color shifts between the front and rear sides	Paper skew on transfer belt <ul style="list-style-type: none"> • Side fences are not correctly set. • Pressure between the paper attraction roller and transfer belt is not even at the front and rear sides. 	Reposition the side fences. Reposition the paper attraction roller unit.	

Adjustment Standard: Max. 150 μm

The flowchart illustrates the procedure to adjust line positions.

NOTE: The allowance of color shift is 150μm. Keep the color shift in the range of 0 to 150μm.

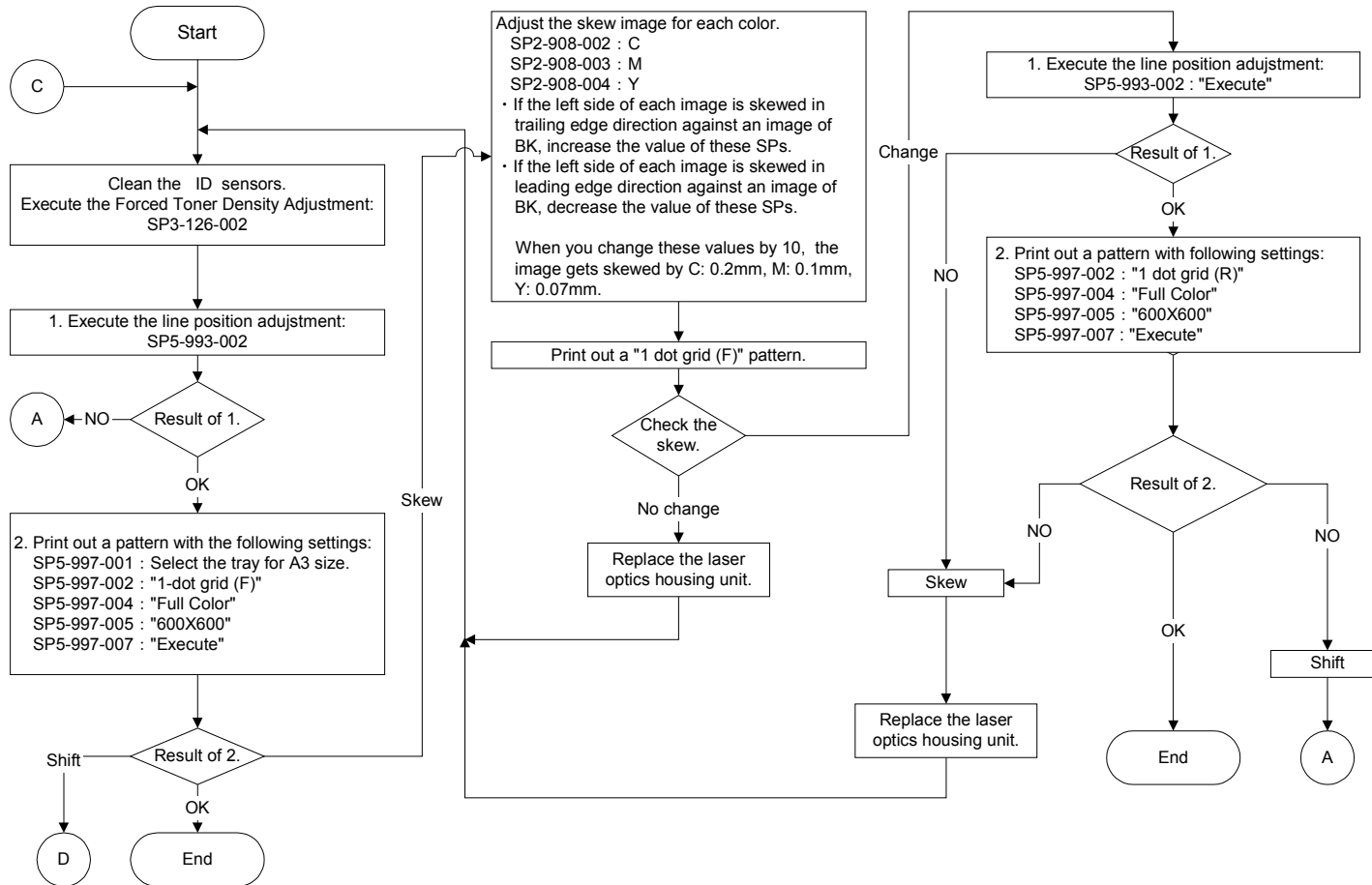

G130T506.WMFF

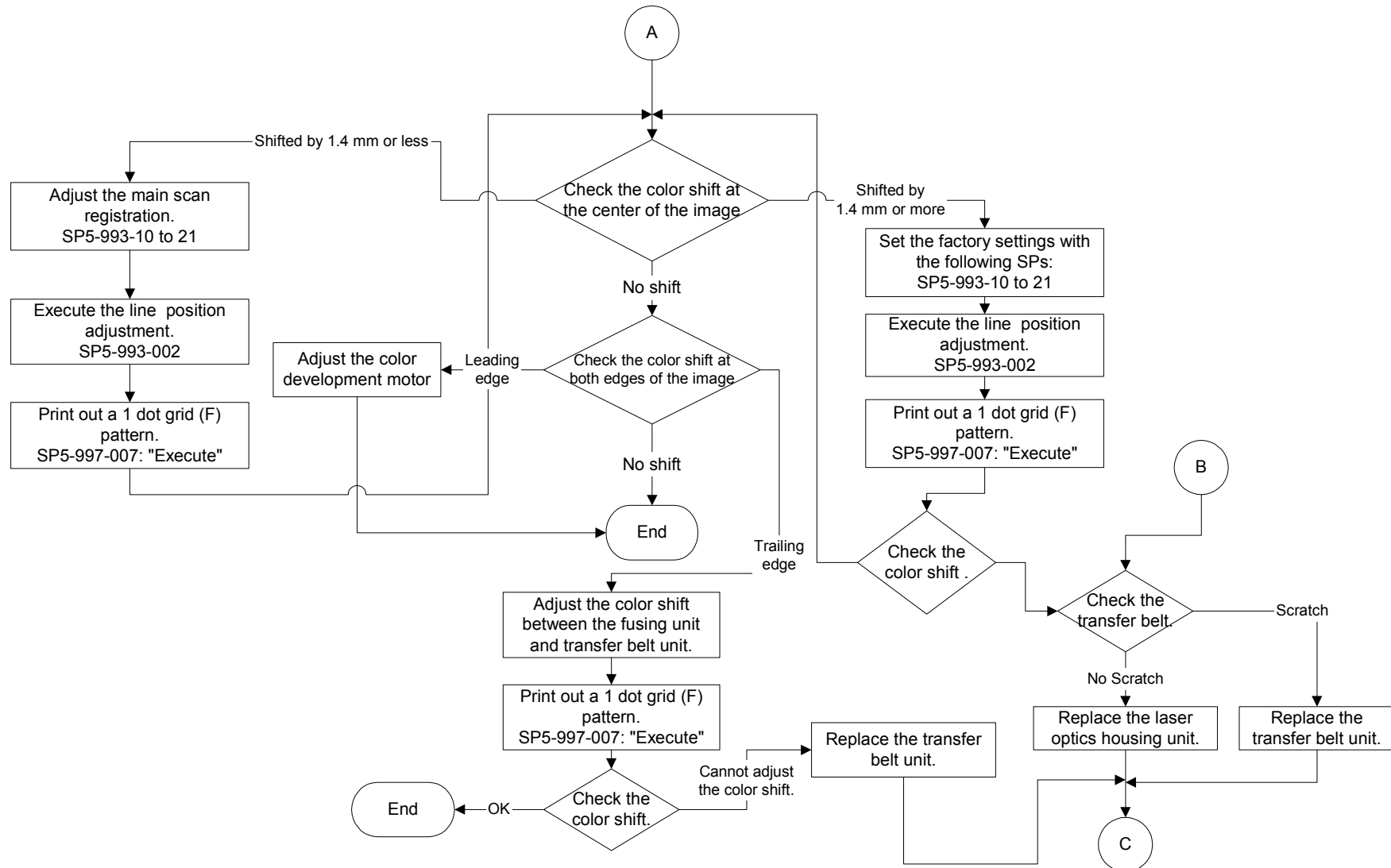

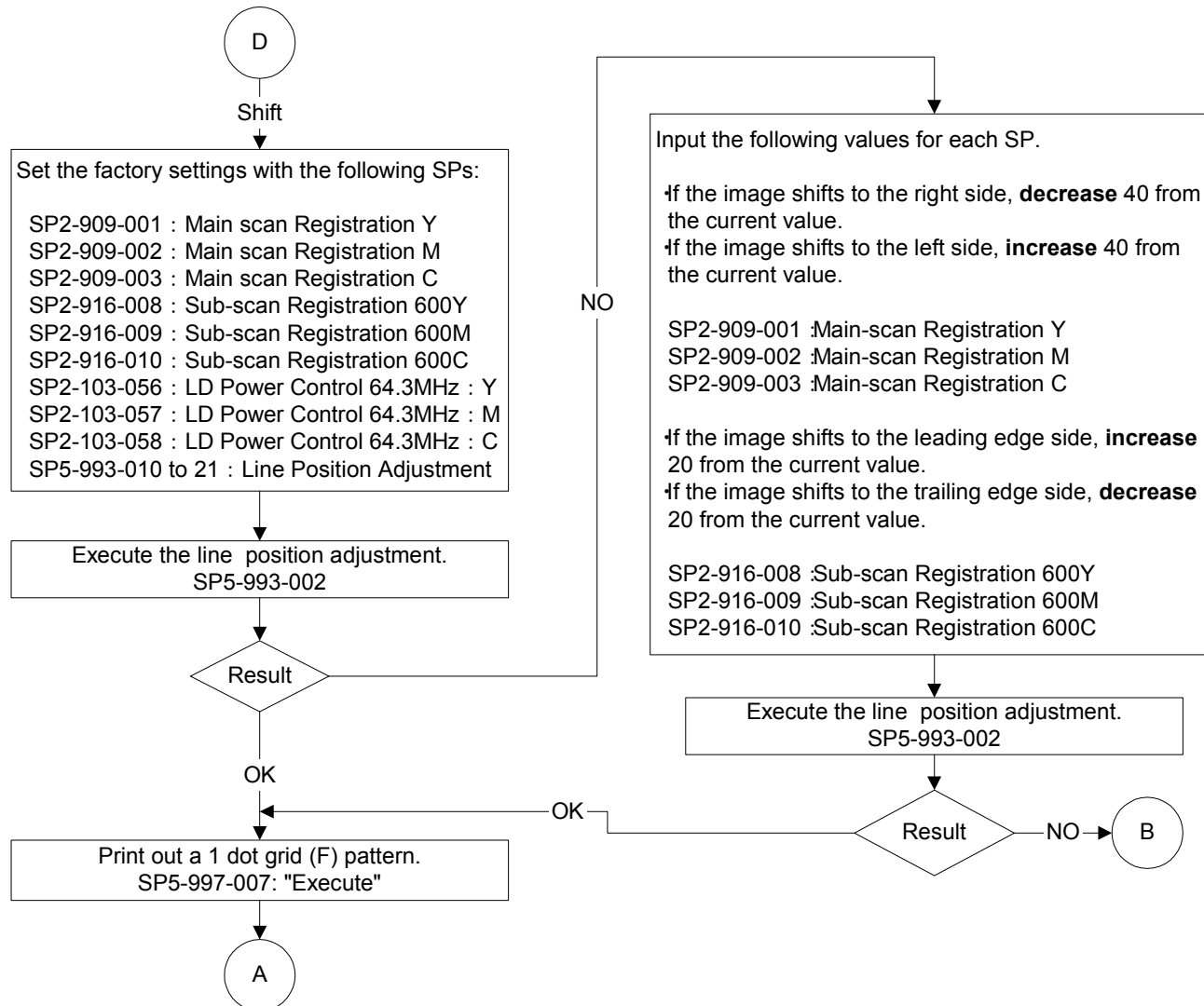

G130T518.WMF

Direction	Area	Symptom	Possible Cause	Action Required		Procedure / Remarks
				Output Mode	SP Mode	
Sub-scan	Leading edge	Color shift, especially 100 mm from the leading edge. (Refer to pattern 1 in the "How to measure the gap between color lines" described after this table.)	Registration roller speed is not suitable for the paper used.	Normal Paper 1200 dpi	SP1-004-004	Check the magenta line position against the black line. If the registration roller is too fast or slow, the magenta line appears above or below the black line. Above: Speed is too fast: Decrease speed Below: Speed is too slow: Increase Speed When adjusting the speed, change the setting in 0.05 steps, and check the result by printing the grid pattern. Then, repeat this until the shift between magenta and black is minimized. NOTE: If the registration roller is too fast, magenta jitter may appear at 67 mm and/or cyan jitter at 165 mm from the trailing edge. This is caused by the mechanical shock when the trailing edge of the paper passes the registration rollers.
				Normal Paper 600 dpi	SP1-004-005	
				Thick Paper 1200 dpi (by-pass feed)	SP1-005-003	
	Trailing edge	Color shift, especially 100 mm from the trailing edge. (Refer to pattern 2 in the "How to measure the gap between color lines" described after this table..)	Fusing roller speed is not suitable for the paper used.	Normal Paper 1200 dpi	SP1-004-001	
				Normal Paper 600 dpi	SP1-004-002	
				Thick Paper 1200 dpi (by-pass feed)	SP1-004-007	

Direction	Area	Symptom	Possible Cause	Action Required		Procedure / Remarks
				Output Mode	SP Mode	
Sub-scan	Entire image	Color shift on the entire image, and the amount of shift from leading to trailing edge is almost the same.	SP mode setting is not suitable for the paper used.	Normal Paper 600 dpi	SP5-993-016 (Y) SP5-993-017 (M) SP5-993-018 (C)	Measure the gap between the black line and other colors (YMC) using a magnification scope. Convert the measured value from [μm] to [dots] with the following formula. Then, add or subtract the calculated dot value in the SP mode. Correction [dots] = Measured value [μm] / 21.2 or 42.4 600 dpi mode: 1 dot = 42.4 μm 1200 dpi mode: 1 dot = 21.2 μm If color (YMC) has shifted up in relation to black, add the above value to the current value. If color (YMC) has shifted down in relation to black, subtract the above value from the current value. Examples <ul style="list-style-type: none"> • If the magenta line has shifted up in relation to black by 40μm in 600dpi mode, add 1 to the current setting of SP5-993-017. Correction [dots] = +(40/42.4) = Approx. +1 • If the magenta line has shifted down in relation to black by 70μm in 600dpi mode, subtract 2 from the current setting of SP5-993-17. Correction [dots] = -(70/42.4) = Approx. -2
				Normal Paper 1200 dpi	SP5-993-019 (Y) SP5-993-020 (M) SP5-993-021 (C)	

Direction	Area	Symptom	Possible Cause	Action Required		Procedure / Remarks
				Output Mode	SP Mode	
Main-scan	Entire image	Color shifts on the entire image, and the amount of shift differs at front, center, and rear. (Refer to pattern 3 in the How to measure the gap between color lines described after this table.)	Main-scan magnification is not correctly adjusted.	-	SP5-993-013 (Y) SP5-993-014 (M) SP5-993-015 (C)	<p>Measure the gap between the black line and other colors (YMC) using a magnification scope. Convert the measured value [mm] to [%] with the following formula. Then, add or subtract the calculated value in the SP mode</p> <p>Correction [%] = Measured value [mm] / 287 x 10000</p> <p>If the color line is enlarged in relation to black, add the correction value to the current setting.</p> <p>If the color line is reduced in relation to black, subtract the correction value from the current setting.</p> <p>NOTE: Line position adjustment (SP5-993-002 or "Auto Adjust" in User Program mode) should be done to check the result after changing the main-scan magnification data. This is because the changes will affect the line position adjustment.</p> <p>Examples</p> <ul style="list-style-type: none"> • If the magenta line is enlarged by 0.1mm in relation to the black line, add "4" to the current setting of SP5-993-014. Correction [%] = (0.1/287) x 10000 = Approx. +4 • If the magenta line is reduced by 0.05 mm in relation to the black line, subtract "2" from the current setting of SP5-993-014. Correction [%] = -(0.05/287) x 10000 = Approx. -2

Direction	Area	Symptom	Possible Cause	Action Required		Procedure / Remarks
				Output Mode	SP Mode	
Main-scan	Entire image	<p>Color shifts on the entire image and amount of shifts is almost the same at front, center, and rear sides.</p> <p>(Refer to pattern 4 in the How to measure the gap between color lines described after this table.)</p>	Main-scan registration is not correctly adjusted.	-	SP5-993-010 (Y) SP5-993-011 (M) SP5-993-012 (C)	<p>Measure the gap between the black line and other colors (YMC) using a magnification scope. Convert the measured value [μm] to [dots] with the following formula. Then, add or subtract the calculated dot value in the SP mode.</p> <p>Correction [dots] = Measured value [μm] / 21.2</p> <p>If color (YMC) has shifted to the left in relation to black, add the above value to the current setting.</p> <p>If color (YMC) has shifted to the right in relation to black, subtract the above value from the current setting.</p> <p>Examples</p> <ul style="list-style-type: none"> • If the magenta line has shifted to the left by $40\mu\text{m}$, add 4 to the current setting of SP5-993-011 Correction [dots] = $+(40/21.2)$ = Approx. +2 • If the magenta line has shifted to the right by $70\mu\text{m}$, subtract 3 from the current setting of SP5-993-011. Correction [dots] = $-(70/21.2)$ = Approx. -3
	Front or rear	The amount of color shift at the front and rear sides becomes gradually bigger toward the trailing edge.	<ul style="list-style-type: none"> • Side fence position • Transfer belt position 	-	-	<ul style="list-style-type: none"> • Check if the side fences of the paper trays are correctly positioned. If there is clearance between the paper and the side fences, this causes paper to skew during paper transport. • Check if the transfer belt is in correct position, if the tension springs are correctly set, or if the paper attraction roller is correctly installed. (☛ 3.7.4 Transfer Belt)

4. DUMMY

4.1 DUMMY

4.2 DUMMY

4.3 DUMMY

4.4 DUMMY

4.5 TROUBLESHOOTING GUIDE 2

4.5.1 DUMMY

4.5.2 DUMMY

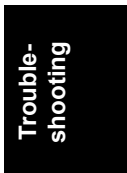

HOW TO MEASURE THE GAP BETWEEN COLOR LINES

Use a magnification scope to measure the gap [A] between the two lines. Measure the distance between the same sides of the two lines. For example (see the illustration), measure between the left edges of the lines.

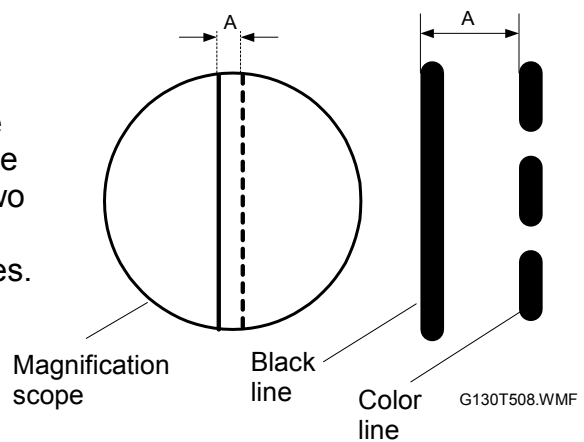

Pattern 1

Color shift in the sub-scan direction at the leading edge

This illustration shows that the colored (dotted) line is above the black line. This means that the registration roller speed is too high for the paper used. Therefore, the registration roller speed needs to be reduced. To do this, decrease the setting (percentage) of SP1-004-004, 005, and SP1-005-003. This depends on the mode selected.

- SP1-004-004 Normal paper, Color mode, 1200 dpi (81 mm/s)
- SP1-004-005 Normal Paper, Color mode, 600 dpi (G130: 125 mm/s, G131: 162 mm/s)
- SP1-005-003 Thick Paper (81 mm/s)

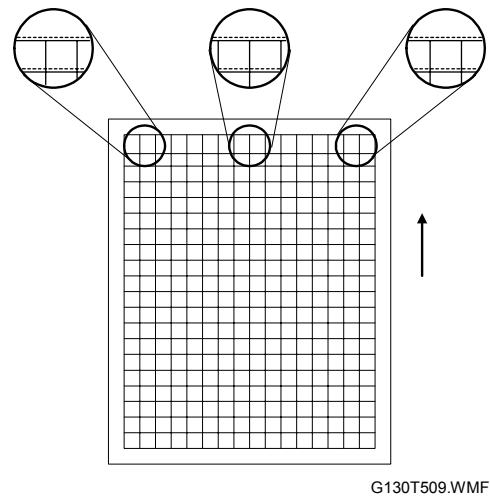

Pattern 2

Color shift in the sub-scan direction at the trailing edge

This illustration shows that the colored (dotted) line is above the black line. This means that the fusing roller speed is too high for the paper used. Therefore, the fusing roller speed needs to be slower. To do this, decrease the setting (percentage) of SP1-004-001, 002, or 007. This depends on the mode selected.

- SP1-004-001 Normal paper, Color mode, 1200 dpi (81 mm/s)
- SP1-004-002 Normal Paper, Color mode, 600 dpi (G130: 125 mm/s, G131: 162 mm/s)
- SP1-004-007 Thick Paper (81 mm/s)

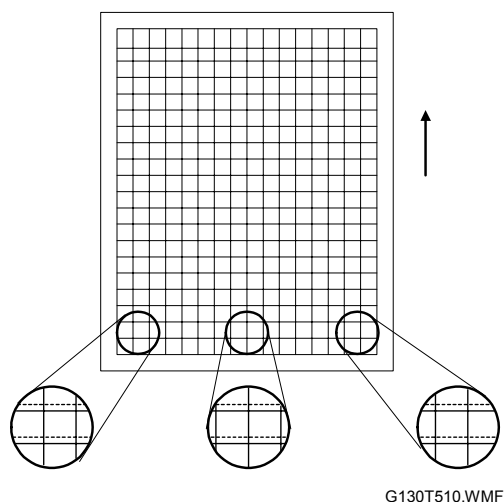

Pattern 3

Color shift (magnification change) in the main-scan direction

Fig. 1 and 2 shows that the colored (dotted) line has shifted away from the black line. The amount of shift is not the same as at the front, center, and rear. Both Fig. 1 and Fig. 2 show that the color grid is larger than the black grid. Yellow becomes larger from left to right in Fig. 1. Cyan and magenta become larger from right to left. This is because the laser writing direction for B&Y is different from C&M.

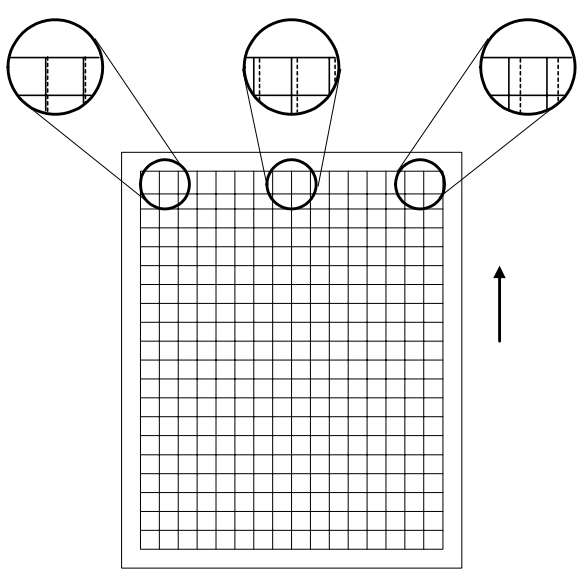

G130T512.WMF

Fig. 1 (Yellow)

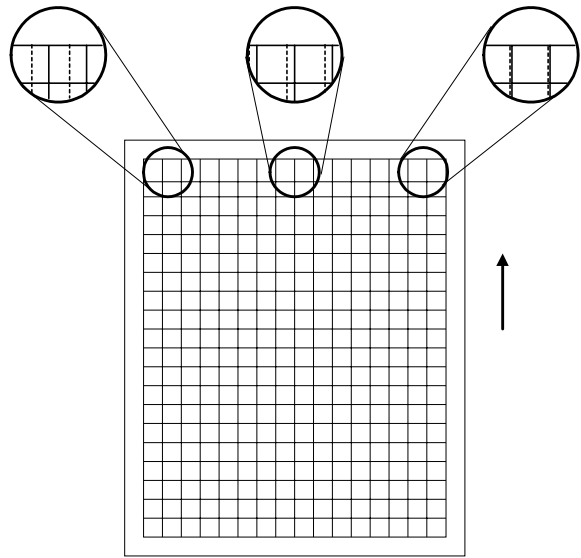

G130T511.WMF

Fig. 2 (Cyan & Magenta)

Trouble-
shooting

Pattern 4

Color shift (registration) in the main-scan direction

Colored line shifts in the main-scan direction. This keeps the amount of shift the same at the left, center, and right.

This is caused by incorrect color registration.

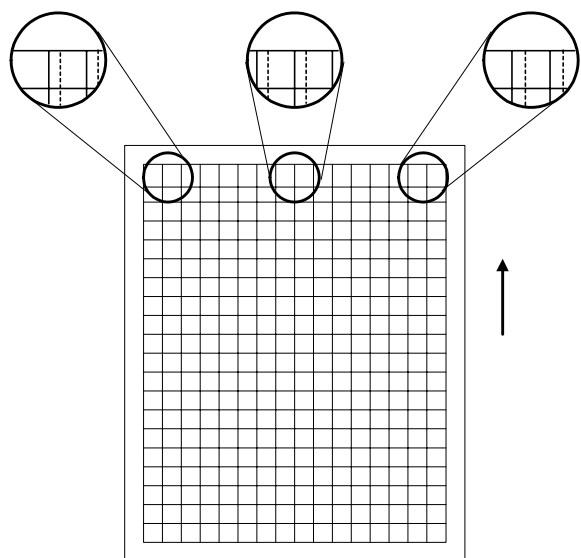

G130T513.WMF

4.5.3 COLOR SHIFT AFTER TRANSFER UNIT REPLACEMENT

Do the following procedure below if the color shift level is not within the target range (max 150 μ m) after you replace the transfer unit and do the forced line position adjustment (SP5-993-002 or Auto Color Registration):

Check the color shift level

1. Make sure that OPC Refresh (SP3-920-005) has been done.
2. Print out the SMC sheets (SP5-990-002).
3. Print a 1-dot grid pattern with A3/11" x 17" paper. Refer to the following table for detailed SP mode settings:

Mode	SP5-997 (Test Pattern) Setting				
	Tray selection	Pattern	Color mode	Resolution	Paper size (By-pass)
Normal, color, 600 dpi	2	05	Full Color	600x600	—
Normal, color, 1200 dpi	2	05	Full Color	1200x1200	—

NOTE: You need to do each adjustment with the paper type normally used by the customer.

4. Check the tendency of color shift in the grid pattern printed in step 3. At times, a magnification scope must be used to measure the amount of color shift between colors.
5. Go to the next step (fusing/registration roller speed adjustment) if the result is not within the target.

Fusing/ Registration Roller Speed Adjustment

SP mode (sub-scan registration) reset

1. Make sure that the SMC sheets (SP5-990-002) have been printed out.
2. Reset the setting of SP5-993-016 to 021 to "0."

Transfer belt aging

1. Remove all PCUs. Place them on clean sheets of paper. Cover the drums with a few sheets of paper to keep the drums away from light. Then secure the drum positioning plate (2 screws). Then return the transfer unit release lever to the original position.
2. Perform the transfer belt idling with SP5-804-066 (Drum M M CW) for about 3 minutes. (This stabilizes the transfer belt side-to-side movement.)
3. Reinstall the PCUs.
4. Perform adjustments (☛ 3.9.1).
5. Print a 1-dot grid pattern with A3/11" x 17" paper in 600 dpi mode.
6. Follow the troubleshooting guide if the color shift in the main-scan direction is not within the adjustment standard.

Fusing roller speed adjustment

1. Do the line position adjustment (SP5-993-002 or "Auto Adjust" in User Program mode).
2. Print a 1-dot grid pattern for each of the following modes with A3/11" x 17" paper.
 - (1) Normal, 600 dpi
 - (2) Normal, 1200 dpi
 - (3) Thick, 1200 dpi
3. Do the troubleshooting procedure (Sub-scan/Trailing edge) if the color has shifted within 100 mm from the trailing edge.

Registration roller speed adjustment (for color mode)

1. Do the line position adjustment (SP5-993-002 or "Auto Adjust" in User Program mode).
2. Print a 1-dot grid pattern for each of the following modes with A3/11" x 17" paper.
 - (1) Normal, 600 dpi
 - (2) Normal, 1200 dpi
3. Do the troubleshooting procedure (Sub-scan/Leading edge) if the color has shifted within 100 mm from the leading edge.

NOTE: The registration roller speed for by-pass paper feed is the same as for normal 1200 dpi mode.

Line position fine adjustment for sub-scan

1. Print a 1-dot grid pattern each for each of the following modes with A3/11" x 17" paper.

Mode	SP5-997 (Test Pattern) Setting				
	Tray selection	Pattern	Color mode	Resolution	Paper size (By-pass)
Normal, color, 600 dpi	2	05	Full Color	600x600	-
Normal, color, 1200 dpi	2	05	Full Color	1200x1200	-
Thick paper	0	05	Full Color	1200x1200	A3 / 11x17

2. Check if there is any color shift from the black line by the same amount all the way down the page from leading to trailing edge. Follow the troubleshooting procedure (Sub-scan/Whole image) if there is.



Registration roller speed adjustment (For B&W mode)

1. Input the following values in the SP modes:
 SP1-004-006 = (Value of SP1-004-005)
 SP1-007-002 = (Value of SP1-004-005)
 SP1-005-002 = (Value of SP1-004-005) – 0.2%
2. Print a 2-dot pattern (pattern 12) with A3/11" x 17" paper.

Mode	SP5-997 (Test Pattern) Setting				
	Tray selection	Pattern	Single Color	Color Mode	Resolution
Normal color 600 dpi	2	12	6 (Black)	Single Color	600x600

3. A horizontal band may show at 60 mm (2.76") from the leading edge on A3 (11" x 17") paper. This depends on the paper used. Decrease the setting of SP1-004-006 in 0.05% steps until the problem is solved if the horizontal band shows on the 2-dot pattern.

4.5.4 BLACK OVER PRINT

Black over print does not let unexpected white lines show when black letters or lines are printed with color background. You can enable or disable this feature from the printer driver (default: disabled).

Black over print has the following bad effects when it is enabled:

- Crispness may deteriorate because the black toner spreads out.
- More toner is consumed.
- The background color may be seen through black letters or lines.

Black Over Print Disabled

Black lines and color background are printed as follows:

1. The color toner (for example, magenta [B] and yellow [A] toner) is transferred on the paper [C]. Some space [D] is left blank for the black toner.
2. The black toner [E] is transferred in the blank space.

An unexpected white line [F] shows if the line position of the black toner is not correct.

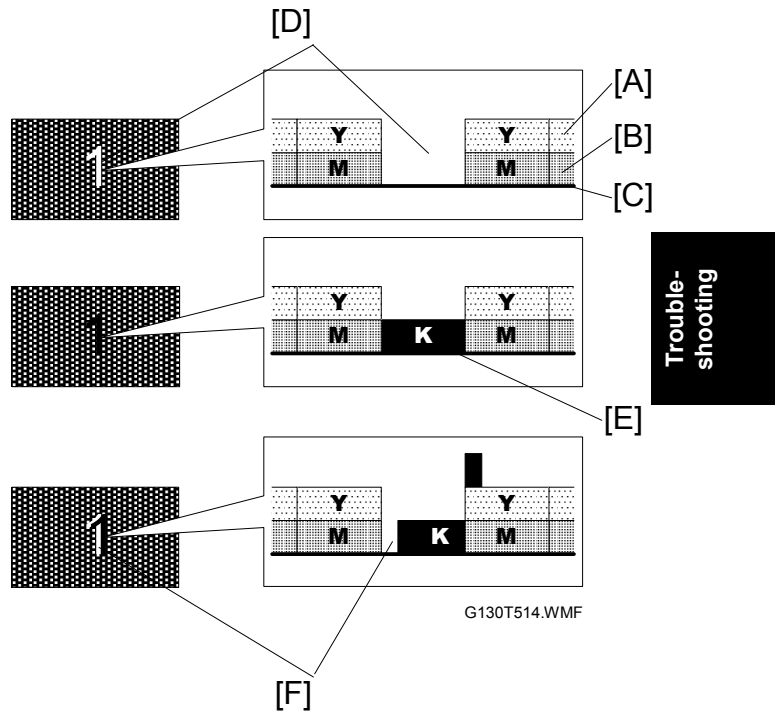

Black Over Print Enabled

Black lines and color background are printed as follows:

1. The color toner (for example, magenta [B] and yellow [A] toner) is transferred on the paper [C].
2. The black toner [D] is transferred on the color toner.

An unexpected white line does not show even if the line position of the black toner is not correct.

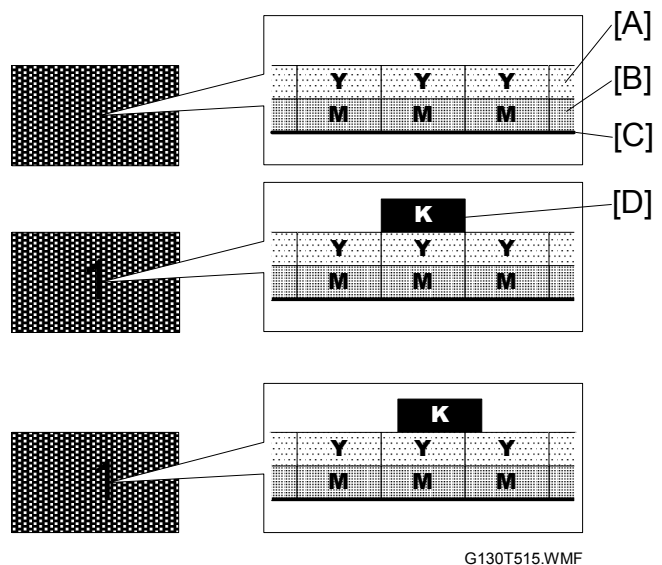

4.6 ELECTRICAL COMPONENT DEFECTS

4.6.1 SENSORS

Component	CN	Condition	Symptom
TD sensor	K: 210-A3 C: 210-B9 M: 209-A19 Y: 210-A9	Open	SC370/371/372/373
		Shorted	SC370/371/372/373 or SC374/375/376/377
Transfer belt sensor	210-A12	Open	SC471
		Shorted	
ID sensor	Rear: 228-3 Center: 228-4, 7 Front: 228-8	Open	SC385
		Shorted	
Paper end sensor	Tray1: 205-A5 Tray2: 205-B9 By-pass: 209-A15	Open	The Paper End indicator lights even if paper is placed in the paper tray.
		Shorted	The Paper End indicator does not light even if there is no paper in the paper tray.
Paper lift sensor	Tray1: 205-A2 Tray2: 205-B6	Open	The bottom plate of the paper feed unit is not lifted up.
		Shorted	SC501/502
Relay sensor	205-A8	Open	Paper Jam is detected whenever a print is made.
		Shorted	Paper Jam is detected even if there is no paper.
Vertical transport sensor	208-B11	Open	Paper Jam is detected whenever a print is made.
		Shorted	Paper Jam is detected even if there is no paper.
Registration sensor	209-B2	Open	Paper Jam is detected whenever a print is made.
		Shorted	Paper Jam is detected even if there is no paper.
Fusing exit sensor	212-A7	Open	Paper Jam is detected whenever a print is made.
		Shorted	Paper Jam is detected even if there is no paper.
Paper exit sensor	212-B5	Open	Paper Jam is detected whenever a print is made.
		Shorted	Paper Jam is detected even if there is no paper.
Paper overflow sensor	212-A2	Open	The paper overflow message is not shown even when a paper overflow condition exists. This causes a paper jam.
		Shorted	The paper overflow message shows.

Component	CN	Condition	Symptom
Toner end sensor	K: 209-A2 Y: 206-A7 C: 206-A4 M: 206-A1	Open	Toner near end may not be detected even when the toner near end condition is satisfied.
		Shorted	Toner near end may be detected even when the toner near end condition is not satisfied.
Drum gear position sensor	K: 213-13 CMY: 210-B12	Open	SC440
		Shorted	
Belt mark sensor	215-3	Open	Dancing control does not function.
		Shorted	
Waste toner sensor	213-4	Open	Waste toner near full message shows, even when a waste toner near full condition does not exist.
		Shorted	Waste toner near full message is not shown even when a waste toner near full condition exists. This causes a waste toner leak.

NOTE: The CN numbers are the connector numbers on the BCU.

4.7 BLOWN FUSE CONDITIONS

Main PSU

The table lists the fuses on the main power supply unit.

Fuse	Rating		Symptom when turning on the main switch
	115 V	220 - 240 V	
FU1	15A/125V	—	No response (No power is supplied to the electrical components.)
CB1	—	8A/250V	
FU2	10A/125V	5 A/250V	No response (No DC power is supplied to the electrical components.)
FU91	10 A/125V	10 A/125V	The 24V DC power is not supplied. The message, "Close Front Cover," shows.
FU92	6.3 A/125V	6.3 A/125V	"SC 471 Power Off On" shows on the operation panel.
FU93	2A/250V	—	No response (No DC power is supplied to the electrical components.)

Sub PSU

The table lists the fuses on the sub power supply unit.

Fuse	Rating		Symptom when turning on the main switch
	115V	220–240V	
F1	4A/250V	3.15A/250V	The two-tray finisher or booklet finisher is not detected. "Close Duplex Unit Cover" shows.
F2	8A/250V	8A/250V	The two-tray finisher or booklet finisher is not detected. "Close Duplex Unit Cover" shows.

4.8 LEDS (BCU)

LED	Status	
	Blinking	Stays OFF or ON
LED 3 (Red)	The Main CPU functions correctly.	The Main CPU does not function correctly.
LED 2 (Green)	The MUSIC CPU functions correctly.	The MUSIC CPU does not function correctly.
LED 1 (Yellow)	The DSP functions correctly.	The DSP does not function correctly.

5. SERVICE TABLES

5.1 SERVICE PROGRAM MODE

⚠ CAUTION

Before you start the service program mode, make sure that the printer is not processing data. The Data In LED lights or blinks when the printer is processing data.

5.1.1 HANDLING SERVICE PROGRAM MODE

⚠ IMPORTANT

Do not let the user get access to the service program mode. If a person other than service representatives gets access to the service program mode, the machine quality is not guaranteed.

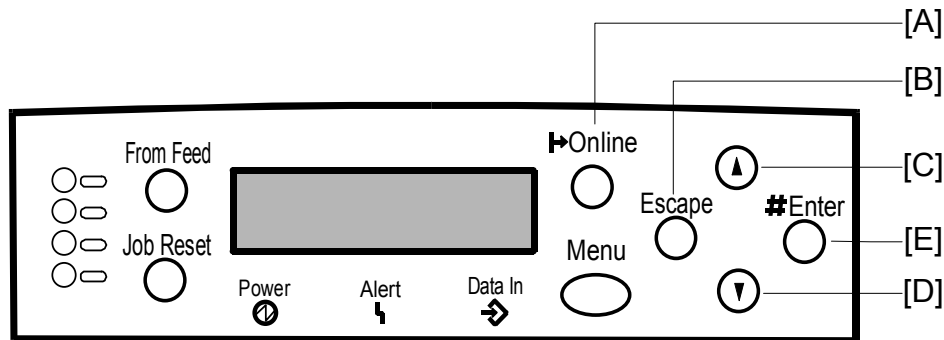

G130S501.WMF

Starting SP Mode

Start the service program mode as shown in procedure A or B.

NOTE: The printer goes offline status while the service program mode is used.

A: When the main power switch is off

1. Push the on-line key [A] and the escape key [B] and hold them down.
2. Turn on the main power switch.
3. Hold the keys until the message "SYSTEM ver X.XX" is shown (where X.XX is the firmware version).

B: When the main power switch is on

1. Push the up arrow key [C] and down key [D] together for 5 seconds or more.
2. Push the enter key. The message "SYSTEM ver X.XX" is shown (where X.XX is the firmware version).

Selecting a Service Program

1. Use the up arrow key or the down arrow key to use one of these:
 - 1. Service: Gets access to the Controller Service Mode
 - 2. Engine: Gets access to the Engine Service Mode
 - 3: End: Goes out of the SP Mode
2. Push the enter key [E].
3. Use the up arrow key or the down arrow key to find the necessary service program.
4. Push the enter key.
5. To go back to step 1, push the escape key one or more times.

Changing a Setting

1. Start a service program (☛Selecting a Service Program). The current setting is shown.
2. Push the up arrow key or the down arrow key to input a value.
3. Push the enter key. The setting is changed.

NOTE: The setting does not change if you do not push the enter key.

To enable some settings, you must turn the main power switch off and on (☛Enabling Settings).

Quitting SP Mode

1. Push the escape key one or more times until one of these is shown
 - 1. Service
 - 2. Engine
2. Push the up arrow key or the down arrow key until this is shown:
 - 3: End
3. Push the enter key.

Enabling Settings

To enable the settings shown in this table, you must turn the main power switch off and on after you go out of SP Mode.

SP Modes Related to the Engine	SP Modes Related to the Controller
SP2-208-009	SP5-009-001
SP2-213-001	SP5-961-001
SP2-224-001 to 004	SP5-824-001
SP5-905-007	SP5-825-001
SP5-930-001 to 005	SP5-869
SP5-994-001 and 002	

Line Position Adjustment

If you change the settings of SP5-993-013 to 015, the new settings have an effect on the next line position adjustment.

5.1.2 REMARKS

Abbreviations and Symbols

These are the symbols and abbreviations in the service mode tables.
(☛ 5.2.1/5.3.1).

Paper Type

N	Normal paper
TH	Thick paper
MT	Middle Thick paper
SP	Special Paper

Color Mode

[Color]	Full-color mode
[K]	Black in B&W mode
[Y]	Yellow in full-color mode
[M]	Magenta in full-color mode
[C]	Cyan in the full-color mode
[YMC]	Yellow, magenta, and cyan
[FC]	Full-color mode
[FC, K]	Black in the full-color mode
[FC, Y]	Same as [Y]
[FC, M]	Same as [M]
[FC, C]	Same as [C]

Paper Feed Station

P	Paper tray
B	By-pass tray

Fusing Section

H	Heating roller
P	Pressure roller

Print Mode

S	Simplex
D	Duplex

Special Setting

FA	Factory setting (The setting could be adjusted before transportation. See the SMC Report behind the front cover.)
DFU	Design/Factory Use only (Do not change the setting.)

Line Speed

H	162 mm/s (only for G130)
M	162 mm/s (G131)/ 125 mm/s (G130)
L	81 mm/s

Storage

*	The setting is stored in the NVRAM (engine) or NVRAM (printer controller). If you clear the RAM, the setting returns to the default.
BCU	The setting is stored in the NVRAM on the BCU board.
CTL	The setting is stored in the NVRAM on the controller board.

Other

#	You must turn the main power switch off and on to enable the setting.
---	---

Service Tables

Possible Values

The service mode tables (☛ 5.2.1/5.3.1) show the possible values as follows:

[Adjustable range / Default setting / Step] Alphanumeric

where “Alphanumeric” shows that the setting is displayed by numbers and letters. In this type of example, the letters are not shown in the service mode tables.

Process Speed

Some service programs are related to the line speed and the print speed. The line speed and the print speed change with the print mode (black & white/color), the resolution, and the paper type as shown in the table.

Mode	Resolution (dpi)	Line speed (mm/s)	Print speed (ppm)
B/W	600 x 600	162	G130: 32
	1,200 x 600		G131: 35
	1,200 x 1,200	81	17
Color	600 x 600	G130: 125	G130: 28
	1,200 x 600	G131: 162	G131: 35
	1,200 x 1,200	81	17
OHP/Thick	600 x 600	81	14
	1,200 x 600		
	1,200 x 1,200		

5.2 CONTROLLER SERVICE MODE

5.2.1 SERVICE MODE TABLE

1001		[Bit Switch]	
1001 001	Bit Switch 1	*CTL	Adjusts bit switch settings. DFU
1001 002	Bit Switch 2	*CTL	
1001 003	Bit Switch 3	*CTL	
1001 004	Bit Switch 4	*CTL	
1001 005	Bit Switch 5	*CTL	
1001 006	Bit Switch 6	*CTL	
1001 007	Bit Switch 7	*CTL	
1001 008	Bit Switch 8	*CTL	

1003		[Clear Setting]	
1003 001	Init. System		Initializes settings in the System menu of the user mode.
1003 003	Delete Program		DFU

1004		[Print Summary]	
Prints the service summary sheet (a summary of all the controller settings).			

1005		[Disp. Version]	
Displays the version of the controller firmware.			

1101		[ToneCtlSet]	
1101 001	Tone (Factory)	*CTL	Recalls a set of gamma settings. This can be either a) the factory setting, b) the previous setting, or c) the current setting.
1101 002	Tone (Prev.)	*CTL	
1101 003	Tone (Current)	*CTL	

1102		[ToneCtlSet]		*CTL	
Sets the printing mode (resolution) for the printer gamma adjustment. The asterisk (*) shows which mode is set.					
		• *1200x1200Photo	• 600x600Text	• 1200x600Text	
		• 1200x1200Text	• 600x600Photo	• 1200x600Photo	

1103		[PrnColorSheet]	
1103 001	ToneCtlSheet		Prints the test page to check the color balance before and after the gamma adjustment.
1103 002	ColorChart		

1104		[ToneCtlValue]	
Adjusts the printer gamma for the mode selected in the Mode Selection menu.			
1104 001	Set Black 1	*CTL	[0 to 255 / <u>16</u> / 1/step]
1104 021	Set Cyan 1	*CTL	
1104 041	Set Magenta 1	*CTL	
1104 061	Set Yellow 1	*CTL	
1104 002	Set Black 2	*CTL	[0 to 255 / <u>32</u> / 1/step]
1104 022	Set Cyan 2	*CTL	
1104 042	Set Magenta 2	*CTL	

1104	[ToneCtlValue]		
	Adjusts the printer gamma for the mode selected in the Mode Selection menu.		
1104 062	Set Yellow 2	*CTL	[0 to 255 / <u>32</u> / 1/step]
1104 003	Set Black 3	*CTL	[0 to 255 / <u>48</u> / 1/step]
1104 023	Set Cyan 3	*CTL	
1104 043	Set Magenta 3	*CTL	
1104 063	Set Yellow 3	*CTL	
1104 004	Set Black 4	*CTL	[0 to 255 / <u>64</u> / 1/step]
1104 024	Set Cyan 4	*CTL	
1104 044	Set Magenta 4	*CTL	
1104 064	Set Yellow 4	*CTL	
1104 005	Set Black 5	*CTL	[0 to 255 / <u>80</u> / 1/step]
1104 025	Set Cyan 5	*CTL	
1104 045	Set Magenta 5	*CTL	
1104 065	Set Yellow 5	*CTL	
1104 006	Set Black 6	*CTL	[0 to 255 / <u>96</u> / 1/step]
1104 026	Set Cyan 6	*CTL	
1104 046	Set Magenta 6	*CTL	
1104 066	Set Yellow 6	*CTL	
1104 007	Set Black 7	*CTL	[0 to 255 / <u>112</u> / 1/step]
1104 027	Set Cyan 7	*CTL	
1104 047	Set Magenta 7	*CTL	
1104 067	Set Yellow 7	*CTL	
1104 008	Set Black 8	*CTL	[0 to 255 / <u>128</u> / 1/step]
1104 028	Set Cyan 8	*CTL	
1104 048	Set Magenta 8	*CTL	
1104 068	Set Yellow 8	*CTL	
1104 009	Set Black 9	*CTL	[0 to 255 / <u>144</u> / 1/step]
1104 029	Set Cyan 9	*CTL	
1104 049	Set Magenta 9	*CTL	
1104 069	Set Yellow 9	*CTL	
1104 010	Set Black 10	*CTL	[0 to 255 / <u>160</u> / 1/step]
1104 030	Set Cyan 10	*CTL	
1104 050	Set Magenta 10	*CTL	
1104 070	Set Yellow 10	*CTL	
1104 011	Set Black 11	*CTL	[0 to 255 / <u>176</u> / 1/step]
1104 031	Set Cyan 11	*CTL	
1104 051	Set Magenta 11	*CTL	
1104 071	Set Yellow 11	*CTL	
1104 012	Set Black 12	*CTL	[0 to 255 / <u>192</u> / 1/step]
1104 032	Set Cyan 12	*CTL	
1104 052	Set Magenta 12	*CTL	
1104 072	Set Yellow 12	*CTL	
1104 013	Set Black 13	*CTL	[0 to 255 / <u>208</u> / 1/step]
1104 033	Set Cyan 13	*CTL	
1104 053	Set Magenta 13	*CTL	
1104 073	Set Yellow 13	*CTL	
1104 014	Set Black 14	*CTL	[0 to 255 / <u>224</u> / 1/step]
1104 034	Set Cyan 14	*CTL	
1104 054	Set Magenta 14	*CTL	
1104 074	Set Yellow 14	*CTL	
1104 015	Set Black 15	*CTL	[0 to 255 / <u>240</u> / 1/step]
1104 035	Set Cyan 15	*CTL	
1104 055	Set Magenta 15	*CTL	
1104 075	Set Yellow 15	*CTL	

1105	[ToneCtlSave]		
	Saves the print gamma (adjusted with the Gamma Adj.) as the new Current Setting. Before the machine stores the new “current setting”, it moves the data stored as the “current setting” to the “previous setting” memory-storage location.		

1106	[Toner Limit]		
	Adjusts the maximum toner amount for image development.		
1106 001	TonerLimitPhot	*CTL	[100 to 400 / <u>260</u> / 1 %/step]
1106 002	TonerLimitText	*CTL	[100 to 400 / <u>190</u> / 1 %/step]

1107	[FactoryTestPrt]		
	Prints the test page to check the color balance before transportation (600 x 600 2 bit). DFU		

5.2.2 BIT SWITCH PROGRAMMING

Do not change the bit switches unless you are told to do this by the manufacturer.

1. Start the SP mode. The “Service” menu is shown.
2. Press the enter key two times.
3. To select a bit switch, press the up arrow key or the down arrow key.
4. Push the enter key.
5. Set the value with these keys:
 - [▲] [▼]: Moves the cursor to one of the adjacent bits.
 - [Escape]: Goes out of the program without saving changes.
 - [Enter]: Goes out of the program and saves changes.

NOTE: The digit at the left [A] is bit 7 and the digit at the right [B] is bit 0.

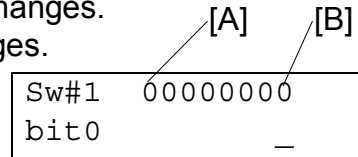

6. Push the escape key one or more times until the menu “Service” is shown.
7. Select “End” and push the enter key.

Service Tables

5.3 ENGINE SERVICE MODE

5.3.1 SERVICE MODE TABLE

SP1-XXX (Feed)

1001	[Lead Edge Reg.] Leading Edge Registration (Paper Type, [Color], Process Speed), Paper Type -> N: Normal, OHP, TH: Thick		
1001 001	N [K] L	*BCU	Adjusts the leading edge registration. This SP changes the registration clutch operation timing. [-10.0 to 10.0 / <u>0.0</u> / 0.1 mm/step] FA
1001 002	N [K] M	*BCU	
1001 003	N [K] H	*BCU	
1001 004	N [FC] L	*BCU	
1001 005	N [FC] M	*BCU	
1001 006	TH [K]	*BCU	
1001 007	TH [FC]	*BCU	
1001 008	OHP [K]	*BCU	
1001 009	OHP [FC]	*BCU	

1002	[S-to-S Reg.] Side-to-Side Registration		
1002 001	By-pass Table	*BCU	Adjusts the side-to-side registration. This SP changes the laser main scan start position. [-10.0 to 10.0 / <u>0.0</u> / 0.1 mm/step] FA
1002 002	Paper Tray 1	*BCU	
1002 003	Paper Tray 2	*BCU	
1002 004	Paper Tray 3	*BCU	
1002 005	Paper Tray 4	*BCU	
1002 006	Duplex	*BCU	

1003	[Paper Buckle] Paper Buckle (Paper Tray or By-pass, Paper Type, Process Speed), Paper Type: N: Normal, TH: Thick		
1003 001	P L	*BCU	Adjusts the amount of paper buckle at the registration roller. This SP changes the paper feed timing. [-10 to 10 / <u>0</u> / 1 mm/step]
1003 002	P M	*BCU	
1003 003	P H	*BCU	
1003 004	B N L	*BCU	
1003 005	B N M	*BCU	
1003 006	B N H	*BCU	
1003 007	B TH	*BCU	
1003 008	B OHP	*BCU	

1004	[Dev. Mt Speed] Development Drive Motor Speed ([Color], Process Speed, Paper Type), Paper Type -> N: Normal, TH: Thick		
	Adjusts the development drive motor speed for correcting color shifts at the leading edge or trailing edge area. Black Motor [K]: Adjusts fusing roller speed for the trailing edge area. Color Motor [YMC]: Adjusts registration roller speed for the leading edge area. NOTE:		
	<ul style="list-style-type: none"> • SP1-004-002 and 005 is for color mode. Fine adjustment for B&W mode can be done with SP1-005-001 and 002. • SP1-004-004 is for normal paper. Fine adjustment for thick paper can be done with SP1-005-003 . 		
	1004 001	[K] L N	*BCU [90.0 to 108.0 / <u>93.9</u> / 0.1 %/step]
	1004 002	[K] M	*BCU [90.0 to 108.0 / <u>93.6</u> / 0.1 %/step]
	1004 003	[K] H	*BCU [90.0 to 108.0 / <u>93.2</u> / 0.1 %/step]
	1004 004	[YMC] L	*BCU [96.00 to 104.00 / <u>100.0</u> / 0.05 %/step]
	1004 005	[YMC] M	*BCU
1004 006	[YMC] H	*BCU	
1004 007	[K] L TH	*BCU [90.0 to 108.0 / <u>93.9</u> / 0.1 %/step]	

1005	[Dev. Mt Speed2] Development Drive Motor Speed 2 ([Color], Process Speed, Paper Type), Paper Type -> TH: Thick		
	1005 001	[K]	*BCU [-0.2 to 1.0 / <u>0.2</u> / 0.1 %/step]
	Adjusts the black development drive motor speed for the B&W 162mm/s process speed. The value stored in this SP mode is different from SP1-004-002 (see the note for SP 1-004). Black development motor speed for B/W at 162 mm/s = Black development motor speed for color mode at 162 mm/s (1-004-002) + 1-005-001. At the 162mm/s process speed, the transfer unit position for B&W is different than for color mode. The transfer unit position affects the paper transport quality, causing the paper to flip up at the fusing section if the same speed as color mode is used for B&W mode. To minimize the occurrence of paper flipping up, which causes smeared images in the trailing area, this SP mode can change the motor speed in B&W mode.		
	1005 002	[YMC]	*BCU [-1.00 to 1.00 / <u>0</u> / 0.05 %/step] FA
Adjusts the color development drive motor speed for the B&W 162mm/s process speed. The value stored in this SP mode is different from SP1-004-005 (see the note for SP 1-004). YMC development motor speed for B/W at 162 mm/s = YMC development motor speed for color mode at 162 mm/s (1-004-005) + 1-005-002 At the 162mm/s process speed, the transfer unit position for B&W is different than for color mode. The transfer unit position affects the paper transport speed slightly. This SP mode can adjust the motor speed for B&W mode.			
1005 003	[YMC] TH	*BCU [-0.30 to 0.30 / <u>0</u> / 0.05 %/step]	
Adjust the color development drive motor speed for thick paper in by-pass mode. The value stored in this SP mode is different from SP1-004-004 (see the note for SP 1-004). Normal and thick paper are different types of paper, and this sometime causes color shift due to paper slippage. This SP mode can change the motor speed for thick paper.			

1005	[Dev. Mt Speed2] Development Drive Motor Speed 2 ([Color], Process Speed, Paper Type), Paper Type -> TH: Thick		
1005 004	Color: L: [K]	*BCU	[-0.40 to 0.40 / <u>0</u> / 0.05 %/step]
	Adjusts the color development drive motor speed for the B&W 81mm/s process speed. The value stored in this SP mode is different from SP1-004-004 (see the note for SP 1-004). YMC development motor speed for B/W at 81 mm/s = YMC development motor speed for color mode at 81 mm/s (1-004-004) + 1-005-004. At the 81 mm/s process speed, the transfer unit position for B&W is different than for color mode. The transfer unit position affects the paper transport speed slightly. This SP mode can adjust the motor speed for B&W mode.		

1006	[Dev. Mt Speed3] Development Drive Motor Speed 3 ([Color], Process Speed, Paper Type), Paper Type -> SP: Special		
	Adjusts the development motor speed for special paper.		
1006 001	[K] L SP	*BCU	[-4.0 to 4.0 / <u>0</u> / 0.1 %/step]
1006 002	[K] M SP	*BCU	
1006 003	[YMC] L SP	*BCU	[-0.4 to 0.4 / <u>-0.1</u> / 0.05 %/step]
1006 004	[YMC] M SP	*BCU	
1006 005	[K] L SP2	*BCU	[-0.4 to 0.4 / <u>0.0</u> / 0.05 %/step]
1006 006	[YMC] L SP2	*BCU	[-0.4 to 0.4 / <u>-0.1</u> / 0.05 %/step]
1006 007	[K] L SP3, 4	*BCU	[-0.4 to 0.4 / <u>0.0</u> / 0.05 %/step]
1006 008	[K] M SP3, 4	*BCU	
1006 009	[K] H SP3, 4	*BCU	[-0.4 to 0.4 / <u>0.0</u> / 0.05 %/step] This SP is only for G130.
1006 010	[YMC] L SP3, 4	*BCU	[-0.4 to 0.4 / <u>-0.1</u> / 0.05 %/step]
1006 011	[YMC] M SP3, 4	*BCU	
1006 012	[YMC] H SP3, 4	*BCU	

1007	[Dev. Mt Speed4] Development Drive Motor Speed 4		
1007 001	[CL] Mail TH	*BCU	[-1.00 to 0.00 / <u>-0.40</u> / 0.05%/step]
	Adjusts the development motor speed for postcards.		
1007 002	[YMC] L [K] TH	*BCU	[-0.40 to 0.40 / <u>0.00</u> / 0.05/step]
	Adjusts the registration line speed for the B&W mode for thick paper. The line speed is calculated as follows: Line speed = SP1-004-004 + SP1-005-003 + SP1-007-002		
1007 003	[K] L TH2, 3, 4	*BCU	[-0.40 to 0.40 / <u>0.00</u> / 0.05/step]
	Adjusts the fusing line speed for the color mode for thick paper 2, 3, 4. The line speed is calculated as follows: Line speed = SP1-004-001 + SP1-007-003		
1007 004	[YMC] L [CL] TH2, 3, 4	*BCU	[-0.40 to 0.40 / <u>-0.1</u> / 0.05/step]
	Adjusts the registration line speed for the color mode for thick paper. The line speed is calculated as follows: Line speed = SP1-004-004 + SP1-007-004		
1007 005	[YMC] L [Bk] TH2, 3, 4	*BCU	[-0.40 to 0.40 / <u>-0.1</u> / 0.05/step]
	Adjusts the registration line speed for the B&W mode for thick paper. The line speed is calculated as follows: Line speed = SP1-004-004+ SP1-007-005		

1008	[Drum MT Speed] Drum Motor Speed Adjustment		
Adjusts the drum speed. This SP does not change the transfer belt speed.			
1008 001	[CL] L	*BCU	[0 to 10 / <u>3</u> / 1 /step] DFU
1008 002	[CL] M	*BCU	
1008 003	[Bk] L	*BCU	
1008 004	[Bk] M	*BCU	
1008 005	OHP	*BCU	
1008 006	MUSIC	*BCU	
1008 008	[Bk] H	*BCU	
1008 009	[CL] L SP2	*BCU	[0 to 10 / <u>3</u> / 1 /step] DFU
1008 010	[Bk] L SP2	*BCU	
1008 011	[CL] L SP3, 4	*BCU	
1008 012	[CL] M SP3, 4	*BCU	
1008 013	[Bk] L SP3, 4	*BCU	
1008 014	[Bk] M SP3, 4	*BCU	
1008 015	[Bk] H SP3, 4	*BCU	
1008 016	[CL] L TH2, 3, 4	*BCU	[0 to 10 / <u>3</u> / 1 /step] DFU
1008 017	[Bk] L TH2, 3, 4	*BCU	

1104	[Fusing Cont.] Fusing Control		
1104 001	Control Method	*BCU	[0 or 1 / <u>0</u> / -] Alphanumeric 0: ON/OFF Control 1: Phase Control
Selects the fusing control method. NOTE: This mode can be used only for N. America models			
1104 025	Process Speed	*BCU	[0 to 8 / <u>4</u> (G130) or <u>5</u> (G131) / 1 /step] 0: CL: L 1: CL: M 2: OHP, Thick 3: B/W: L 4: B/W: H 5: B/W: M 6: CL: M MidThick 7: B/W: H MidThick 8: B/W: M MidThick
Selects the power-on default target fusing operation temperature. The target operating fusing temperature depends on the process speed. When the machine is switched on, it starts warming up for the process speed specified in this SP mode.			
1104	[Fusing Stand By]		
1104 026	H: Offset Temp	*BCU	[-20 to 20 / <u>15</u> / 1°C /step]
Sets the heating roller offset temperature for the 1st print condition after the heating roller temperature reaches the ready temperature.			
1104 027	P: Offset Temp	*BCU	[-20 to 20 / <u>5</u> / 1°C /step]
Sets the pressure roller offset temperature for the 1st print condition after the pressure roller temperature reaches the ready temperature.			
1104 028	H: Offset Temp	*BCU	[-20 to 20 / <u>15</u> / 1°C /step]
Sets the heating roller offset temperature for the 1st print condition before the heating roller temperature reaches the ready temperature..			
1104 029	P: Offset Temp	*BCU	[-20 to 20 / <u>5</u> / 1°C /step]
Sets the heating roller offset temperature for the 1st print condition before the pressure roller temperature reaches the ready temperature..			

Service Tables

1104	[Fusing Cont.] Fusing Control		
1104 031	Temp Control	*BCU	[0 to 2 / <u>2</u> / 1 /step] Alphanumeric 0: off 1: out of FD/FU Single on 2: on The meanings of displayed "FD" and "FU" FD: When a single printed paper is fed to the standard tray FU: When a printed paper is fed to the external tray.
Selects the temperature control condition.			

1105	[Fusing Temp.] Fusing Temperature (Heating or Pressure roller: Paper Type, [Color], Simplex/Duplex, Process Speed) Paper Type -> N: Normal, OHP. TH: Thick, MT: Middle Thick, SP: Special Some settings of fusing temperature depend on the destination (US or Europe/Asia). US: Setting for US, EU: Setting for Europe/Asia		
1105 001	H: Ready	*BCU	[10 to 100 / <u>10</u> / 1°C/step] Sets the heating roller temperature for the printing ready condition. After the main switch has been turned on, the machine enters the print ready condition when the heating roller temperature reaches the temperature specified in this SP mode. When the machine is in the recovery mode from the energy saver or auto off mode, the machine becomes ready when both heating and pressure roller temperatures reach the specified temperature. Ready temperature = (Target temperature specified in SP1-104-25 or 105-4 to 129) – Temperature specified in this SP mode.
1105 002	P: Ready	*BCU	[10 to 100 / <u>30</u> / 1°C/step] Sets the pressure roller temperature for the printing ready condition. Ready temperature = (Target temperature specified in SP1-104-25 or 105-4 to 129) – Temperature specified in this SP mode
The following SPs set the target temperatures of the heating and pressure rollers. (NA: North America, EU: Europe and Asia, L: Low speed [81 mm/s], M: Middle speed [125 mm/s (G130)/162 mm/s (G131)], H: High speed [162 mm/s (only for G130)])			
1105 004	H: N [K] S M	*BCU	[100 to 190 / <u>160</u> / 5°C/step] Only for G131
1105 005	H: N [K] S H	*BCU	[100 to 190 / <u>160</u> / 5°C/step] Only for G130
1105 006	H: N [K] D M	*BCU	[100 to 190 / <u>160</u> / 5°C/step] Only for G131
1105 007	H: N [K] D H	*BCU	[100 to 190 / <u>160</u> / 5°C/step] Only for G130
1105 008	H: N [FC] S L	*BCU	[100 to 190 / <u>135</u> / 5°C/step]
1105 009	H: N [FC] S M	*BCU	[100 to 190 / G130: <u>140</u> , G131: <u>160</u> / 5°C/step]
1105 010	H: N [FC] D L	*BCU	[100 to 190 / <u>135</u> / 5°C/step]
1105 011	H: N [FC] D M	*BCU	[100 to 190 / G130: <u>140</u> , G131: <u>160</u> / 5°C/step]
1105 013	H: OHP	*BCU	[100 to 190 / <u>145</u> / 5°C/step]
1105 015	P: N [K] S M	*BCU	[0 to 190 / <u>145</u> / 5°C/step] Only for G131
1105 016	P: N [K] S H	*BCU	[0 to 190 / <u>145</u> / 5°C/step] Only for G130
1105 017	P: N [K] D M	*BCU	[0 to 190 / <u>145</u> / 5°C/step] Only for G131
1105 018	P: N [K] D H	*BCU	[0 to 190 / <u>145</u> / 5°C/step] Only for G130
1105 019	P: N [FC] S L	*BCU	[0 to 190 / <u>130</u> / 5°C/step]
1105 020	P: N [FC] S M	*BCU	[0 to 190 / G130: <u>130</u> , G131: <u>145</u> / 5°C/step]
1105 021	P: N [FC] D L	*BCU	[0 to 190 / <u>130</u> / 5°C/step]
1105 022	P: N [FC] D M	*BCU	[0 to 190 / G130: <u>130</u> , G131: <u>145</u> / 5°C/step]
1105 024	P: OHP	*BCU	[0 to 190 / <u>130</u> / 5°C/step]

1105	[Fusing Temp.] Fusing Temperature (Heating or Pressure roller: Paper Type, [Color], Simplex/Duplex, Process Speed) Paper Type -> N: Normal, OHP. TH: Thick, MT: Middle Thick, SP: Special Some settings of fusing temperature depend on the destination (US or Europe/Asia). US: Setting for US, EU: Setting for Europe/Asia		
1105 026	H: TH	*BCU	[0 to 190 / <u>155</u> / 5°C/step]
1105 028	P: TH	*BCU	[0 to 190 / <u>135</u> / 5°C/step]
1105 029	H: Envelop	*BCU	[0 to 190 / <u>155</u> / 5°C/step]
1105 030	P: Envelop	*BCU	[0 to 190 / <u>135</u> / 5°C/step]
1105 031	H: Offset Temp	*BCU	[1 to 20 / <u>5</u> / 1°C/step]
	Sets the heating roller temperature for the printing start condition when changing the process speed. Fusing temperature must be decreased when the machine changes to a process speed that is slower than the current process speed (for example, when the speed changes from 162 mm/s to 81 mm/s). The machine idles while reducing the fusing temperature. When the fusing temperature becomes lower than the ready temperature, the machine starts printing. Ready Temperature = Target temperature + Temperature specified in this SP mode.		
1105 032	P: Offset Temp	*BCU	[1 to 20 / <u>10</u> / 1°C/step]
	Sets the pressure roller temperature for the printing start condition when changing the process speed.		
1105 033	H: SP: L	*BCU	[-20 to 30 / <u>-5</u> / 1°C/step]
1105 034	H: SP: M	*BCU	
1105 035	H: SP: H	*BCU	[-20 to 30 / <u>-5</u> / 1°C/step] Only for G130
1105 036	P: SP: L	*BCU	[-20 to 30 / <u>-5</u> / 1°C/step]
1105 037	P: SP: M	*BCU	[-20 to 30 / <u>-5</u> / 1°C/step]
1105 038	P: SP: H	*BCU	[-20 to 30 / <u>-5</u> / 1°C/step] Only for G130
1105 051	H: N [K] S: L	*BCU	[100 to 190 / <u>135</u> / 5°C/step]
1105 052	H: N [K] D: L	*BCU	
1105 053	P: N [K] S: L	*BCU	[100 to 190 / <u>130</u> / 5°C/step]
1105 054	P: N [K] D: L	*BCU	
1105 055	H: MT [K] S M	*BCU	[100 to 190 / <u>175</u> / 5°C/step] Only for G131
1105 056	H: MT [K] S H	*BCU	[100 to 190 / <u>175</u> / 5°C/step] Only for G130
1105 057	H: MT [K] D M	*BCU	[100 to 190 / <u>175</u> / 5°C/step] Only for G131
1105 058	H: MT [K] D H	*BCU	[100 to 190 / <u>175</u> / 5°C/step] Only for G130
1105 059	H: MT [FC] S L	*BCU	[100 to 190 / <u>140</u> / 5°C/step]
1105 060	H: MT [FC] S M	*BCU	[100 to 190 / G130: <u>155</u> , G131: <u>175</u> / 5°C/step]
1105 061	H: MT [FC] D L	*BCU	[100 to 190 / <u>140</u> / 5°C/step]
1105 062	H: MT [FC] D M	*BCU	[100 to 190 / G130: <u>155</u> , G131: <u>175</u> / 5°C/step]
1105 063	P: MT [K] S M	*BCU	[100 to 190 / <u>150</u> / 5°C/step] Only for G131
1105 064	P: MT [K] S H	*BCU	[100 to 190 / <u>150</u> / 5°C/step] Only for G130
1105 065	P: MT [K] D M	*BCU	[100 to 190 / <u>150</u> / 5°C/step] Only for G131
1105 066	P: MT [K] D H	*BCU	[100 to 190 / <u>150</u> / 5°C/step] Only for G130
1105 067	P: MT [FC] S L	*BCU	[100 to 190 / <u>135</u> / 5°C/step]
1105 068	P: MT [FC] S M	*BCU	[100 to 190 / G130: <u>140</u> , G131: <u>150</u> / 5°C/step]
1105 069	P: MT [FC] D L	*BCU	[100 to 190 / <u>135</u> / 5°C/step]
1105 070	P: MT [FC] D M	*BCU	[100 to 190 / G130: <u>140</u> , G131: <u>150</u> / 5°C/step]
1105 071	H: MT [K] S L	*BCU	[100 to 190 / <u>140</u> / 5°C/step]
1105 072	H: MT [K] D L	*BCU	
1105 073	P: MT [K] S L	*BCU	[100 to 190 / <u>135</u> / 5°C/step]
1105 074	P: MT [K] D L	*BCU	
1105 081	H: SP2 [K] S L	*BCU	[100 to 190 / <u>155</u> / 5°C/step]
1105 082	H: SP2 [K] D L	*BCU	
1105 083	H: SP2 [FC] S L	*BCU	

1105	[Fusing Temp.] Fusing Temperature		
	(Heating or Pressure roller: Paper Type, [Color], Simplex/Duplex, Process Speed) Paper Type -> N: Normal, OHP. TH: Thick, MT: Middle Thick, SP: Special Some settings of fusing temperature depend on the destination (US or Europe/Asia). US: Setting for US, EU: Setting for Europe/Asia		
1105 084	H: SP2 [FC] D L	*BCU	[100 to 190 / <u>155</u> / 5°C/step]
1105 085	P: SP2 [K] S L	*BCU	[100 to 190 / <u>135</u> / 5°C/step]
1105 086	P: SP2 [K] D L	*BCU	
1105 087	P: SP2 [FC] S L	*BCU	
1105 088	P: SP2 [FC] D L	*BCU	
1105 090	H: SP3 [K] S L	*BCU	[100 to 190 / <u>155</u> / 5°C/step]
1105 091	H: SP3 [K] D L	*BCU	
1105 092	H: SP3 [FC] S L	*BCU	
1105 093	H: SP3 [FC] D L	*BCU	
1105 094	P: SP3 [K] S L	*BCU	[100 to 190 / <u>135</u> / 5°C/step]
1105 095	P: SP3 [K] D L	*BCU	
1105 096	P: SP3 [FC] S L	*BCU	[100 to 190 / <u>135</u> / 5°C/step]
1105 097	P: SP3 [FC] D L	*BCU	[100 to 190 / <u>135</u> / 5°C/step]
1105 098	H: SP3 [K] S M	*BCU	[100 to 190 / <u>170</u> / 5°C/step] Only for G131
1105 099	H: SP3 [K] D M	*BCU	
1105 100	H: SP3 [FC] S M	*BCU	[100 to 190 / G130: <u>165</u> , G131: <u>170</u> / 5°C/step]
1105 101	H: SP3 [FC] D M	*BCU	
1105 102	P: SP3 [K] S M	*BCU	[100 to 190 / <u>150</u> / 5°C/step] Only for G131
1105 103	P: SP3 [K] D M	*BCU	
1105 104	P: SP3 [FC] S M	*BCU	[100 to 190 / G130: <u>145</u> , G131: <u>150</u> / 5°C/step]
1105 105	P: SP3 [FC] D M	*BCU	
1105 106	H: SP3 [K] S H	*BCU	[100 to 190 / <u>170</u> / 5°C/step] Only for G130
1105 107	H: SP3 [K] D H	*BCU	
1105 108	P: SP3 [K] S H	*BCU	[100 to 190 / <u>150</u> / 5°C/step] Only for G130
1105 109	P: SP3 [K] D H	*BCU	
1105 110	H: SP4 [K] S L	*BCU	[100 to 190 / <u>180</u> / 5°C/step]
1105 111	H: SP4 [K] D L	*BCU	
1105 112	H: SP4 [FC] S L	*BCU	
1105 113	H: SP4 [FC] D L	*BCU	
1105 114	P: SP4 [K] S L	*BCU	[100 to 190 / <u>160</u> / 5°C/step]
1105 115	P: SP4 [K] D L	*BCU	
1105 116	P: SP4 [FC] S L	*BCU	
1105 117	P: SP4 [FC] D L	*BCU	
1105 118	H: TH2 [K] L	*BCU	[100 to 190 / <u>155</u> / 5°C/step]
1105 119	H: TH2 [FC] L	*BCU	
1105 120	H: TH3 [K] L	*BCU	
1105 121	H: TH3 [FC] L	*BCU	
1105 122	H: TH4 [K] L	*BCU	[100 to 190 / <u>180</u> / 5°C/step]
1105 123	H: TH4 [FC] L	*BCU	
1105 124	P: TH2 [K] L	*BCU	[100 to 190 / <u>135</u> / 5°C/step]
1105 125	P: TH2 [FC] L	*BCU	
1105 126	P: TH3 [K] L	*BCU	
1105 127	P: TH3 [FC] L	*BCU	
1105 128	P: TH4 [K] L	*BCU	[100 to 190 / <u>160</u> / 5°C/step]
1105 129	P: TH4 [FC] L	*BCU	

1106	[Temp. Display] Fusing Temperature Display (Heating or Pressure)		
	Displays the current temperature of the heating and pressure rollers.		
1106 001	H Roller		[0 to 230 / - / 1°C/step]
1106 002	P Roller		

1902	[Paper Size] Tray Paper Size		
1902 001	Tray 1 A4/LT	*BCU	[0 or 1 / 0 / -] Alphanumeric 0: A4, 1: LT
	Specifies the paper size for tray 1. Tray 1 can only use these two sizes. US: 1 FA		
1902 002	Tray 2 B4/LG	*BCU	[0 or 1 / 0 / -] Alphanumeric 0: B4, 1: LG
	Specifies the paper size for tray 2. This specifies which size is detected for a sensor output of 1101 (see section 6 for details). US: 1 FA		
1902 003	Tray 2 A4/LT	*BCU	[0 or 1 / 0 / -] Alphanumeric 0: A4, 1: LT
	Specifies the paper size for tray 2. This specifies which size is detected for a sensor output of 0110 (see section 6 for details). US: 1 FA		
1902 004	Tray 2 B5/LT	*BCU	[0 or 1 / 0 / -] Alphanumeric 0: LT, 1: B5
	Specifies the paper size for tray 2. This specifies which size is detected for a sensor output of 1011 (see section 6 for details).		

1912	[Machine Temp.] Machine Temperature Correction		
	Th: Threshold, Heating or Pressure roller		
	Corrects the fusing temperature depending on the temperature inside the machine. If the temperature inside the machine is too high or low, this may cause hot or cold offset image at the fusing section. To avoid the offset image, the fusing temperature is corrected depending on the temperature inside machine, which is monitored by the thermistor located on the right side of the laser optics housing unit. If the temperature inside the machine is detected as high or low (based on the settings of SP1-912-001 or 002), the fusing temperature is decreased or increased by the temperature specified in SP1-912-003 to 006.		
1912 001	Th:High Temp	*BCU	[0 to 50 / 30 / 1°C/step]
	Sets the threshold for entering the high temperature condition.		
1912 002	Th:Low Temp	*BCU	[0 to 50 / 17 / 1°C/step]
	Sets the threshold for entering the low temperature condition.		
1912 003	H: High Temp	*BCU	[0 to 15 / 0 / 1°C/step]
	Sets the fusing temperature decrease for the high temperature condition.		
1912 004	P: High Temp	*BCU	[0 to 15 / 0 / 1°C/step]
1912 005	H: Low Temp	*BCU	[0 to 15 / 5 / 1°C/step]
	Sets the fusing temperature increase for the low temperature condition.		
1912 006	P: Low Temp	*BCU	[0 to 15 / 5 / 1°C/step]
1912 007	H: Temp Control	*BCU	[10 to 50 / 34 / 1°C/step]
	Decreases the fusing temperature by 10 °C if the temperature inside machine, which is monitored by the thermistor located on the left side of the laser optics housing unit, reaches the set temperature in this SP.		

1913	[Temp. Cor. 1] Fusing Temperature Correction (Correction Timing)		
	Specifies the number of sheets to determine whether or not to apply the fusing temperature correction. During a multi print job, the fusing temperature tends to slightly overshoot around the 10th sheet and then stabilize. Temperature overshooting may cause the glossiness to increase. To minimize the overshooting, both fusing and pressure roller temperatures are decreased by the amount specified in SP1-914 at the number of sheets specified in this SP mode, until the end of the job. The temperatures are decreased in two steps. Example: 162 mm/s line speed for G131 First step (also called 'Mode 1'): After 20 sheets (SP 1-913-2), temperature drops by 5°C (SP 1-914-2). Second step (also called 'Mode 2'): After 50 sheets (SP 1-913-7), temperature drops by 10°C (SP 1-914-7). Narrow: LT/A4 SEF width or less Wide: Wider than LT/A4 SEF		
	1913 001	Mode 1: H	*BCU [1 to 255 / <u>20</u> / 1 sheet/step] Only for G130
	1913 002	Mode 1: M	*BCU [1 to 255 / <u>20</u> / 1 sheet/step]
	1913 003	Mode 1: L	*BCU
	1913 004	Mode 1 OHP narrow	*BCU
	1913 005	Mode 1: H: wide	*BCU
	1913 006	Mode 2: H	*BCU [1 to 255 / <u>50</u> / 1 sheet/step] Only for G130
	1913 007	Mode 2: M	*BCU [1 to 255 / <u>50</u> / 1 sheet/step]
	1913 008	Mode 2: L	*BCU
	1913 009	Mode 2: H: narrow	*BCU
1913 010	Mode 2: H: wide	*BCU	

1914	[Temp. Cor. 2] Fusing Temperature Correction (Temperature Setting)		
	Specifies the temperature to be subtracted from the target temperatures specified in SP1-105-4 to-30. Narrow: LT/A4 SEF width or less Wide: Wider than LT/A4 SEF		
	1914 001	Temp 1:H	*BCU [0 to 20 / <u>5</u> / 5°C /step] Only for G130
	1914 002	Temp 1:M	*BCU [0 to 20 / <u>0</u> / 5°C /step]
	1914 003	Temp 1:L	*BCU [0 to 20 / <u>0</u> / 5°C /step]
	1914 004	Temp 1 OHP narrow	*BCU [0 to 20 / <u>0</u> / 5°C /step]
	1914 005	Temp 1 OHP wide	*BCU
	1914 006	Temp 2:H	*BCU [0 to 20 / <u>0</u> / 5°C /step] Only for G130
	1914 007	Temp 2:M	*BCU [0 to 20 / <u>0</u> / 5°C /step]
	1914 008	Temp 2:L	*BCU
	1914 009	Temp 2 OHP narrow	*BCU [0 to 20 / <u>0</u> / 5°C /step]
1914 010	Temp 2 OHP wide	*BCU	

1915	[Stand-by Time]		
	1915 001	Job Receiving	*BCU [0 to 180 / <u>60</u> / 10 seconds/step] 0: The machine does not shift to the stand-by mode.
	Specifies the time to shift the machine into the stand-by mode when not receiving a print start command after receiving a print preparation command.		
1915 002	Job End	*BCU [0 to 180 / <u>30</u> / 10 seconds/step] 0: The machine does not shift to the stand-by mode.	
	Specifies the time to shift the machine into the stand-by mode after the last job is completed.		

1916		[Idling Mode]	
1916 001	Mode Set	*BCU	[0 to 1 / <u>0</u> / 1 /step] Alphanumeric 0: OFF, 1: ON
	Executes the extra idling operation after the fusing unit becomes ready just after the main switch has been turned on.		
1916 002	Idling Time	*BCU	[10 to 120 / <u>30</u> / 10 sec/step]
	Specifies how long the extra idling operation is executed.		
1916 003	PreJob Mode	*BCU	[0 or 1 / <u>0</u> / 1 /step] 0: OFF 1: ON
	Executes the extra idling operation (4 seconds) after the fusing unit becomes ready when a print job arrives at the printer.		
1916 004	Idling Time SP: H	*BCU	[0 to 360 / <u>0</u> / 1 sec/step] DFU
	Specifies how long the extra idling operation is executed when special paper is used.		
1916 005	Pre Job Mode WUP	*BCU	[0 to 3 / <u>1</u> / 1 /step] Alphanumeric 0: H: on, M: off 1: H: on, M: on 2: H: off, M: on 3: H: off, M: off
	<p>Executes the idling operation if the process speed of a job meets this setting (combination between high and middle speed) after meeting following conditions.. The idling operation continues until the fusing temperature reaches the printing ready condition.</p> <ul style="list-style-type: none"> • Turning the main power on • Recovering energy saver mode and off mode • Jam recovery • Door open <p>L: Low speed 81 mm/s (for all models) M: Middle speed 125 mm/s (for G130) or 162 mm/s (for G131) H: High speed 162 mm/s (only for G130)</p>		
1916 006	PreJob Mode Norm	*BCU	[0 to 1 / <u>1</u> / 1 /step] Alphanumeric 0: OFF, 1: ON
	Executes the idling operation for 2 seconds if the fusing temperature reaches the printing ready condition when receiving a job for middle thick paper in color printing mode.		

1917		[Env Condition] Environmental Correction Condition	
1917 001	Time	*BCU	[0 to 23.5 / <u>23.5</u> / 0.5 hour/step]
	The machine cancels the environmental correction for low temperature (SP1-912) after a prescribed time has passed after the machine is turned on, or, recovers from energy saver mode.		

1996	[OHP/TH Fusing] OHP/Thick Paper Fusing Temperature Correction (Heating or Pressure Roller)		
	<p>Specifies the temperature for starting a print job. The fusing section is already warmed up when the last print job was completed. If prints are made on OHP or thick paper at this time, the fusing temperature tends to be higher than the target, causing exit roller marks or a paper jam in the fusing section. To prevent this, the print job will not start if the heating and pressure roller temperatures are higher than the following: (Target temperature specified by SP1-105-13 and -24 for OHP/ SP1-105-26 and -28 for Thick paper) - (Temperature specified by this SP mode (default: 5°C for heating roller, 10°C for pressure roller))</p>		
1996 004	H:Print Temp	*BCU	[0 to 20 / 0 / 1°C /step]
1996 005	P: Print Temp	*BCU	[0 to 20 / 0 / 1°C /step]
1996 006	PreJob Mode	*BCU	[0 to 1 / 0 / 1 /step] Alphanumeric 0: OFF, 1: ON
	This SP enables or disables the 30-second fusing unit idling at the start of an OHP print job. When enabled, idling is done even if the machine is in the ready condition.		

SP2-XXX (Drum)

2001	[Charge Bias] Charge Roller Bias (DC or AC component: [Color], Process Speed) U: Upper, L: Lower		
Adjusts the DC component of the charge roller bias in the various print modes. Charge bias (DC component) is automatically adjusted during process control; therefore, adjusting these settings does not effect while process control mode (SP3-125 Default: ON) is activated. When deactivating process control mode with SP3-125, the values in these SP modes are used for printing.			
2001 001	DC: [K]	*BCU	[300 to 1000 / <u>620</u> / 10 volts/step] DFU
2001 002	DC: [Y]	*BCU	
2001 003	DC: [M]	*BCU	
2001 004	DC: [C]	*BCU	
<ul style="list-style-type: none"> • Displays the AC component of the charge roller bias adjusted during machine initialization or process control self-check. • Sets AC bias in the various print modes for test purposes. If the optimum AC bias cannot be selected because of the settings of SP2-001-014 through 017, this may cause white spots on images and black spots on background. (In particular, spots may appear if the room temperature is very low.) Check the printouts after changing the AC bias with these SP modes (SP2-001-005 through 013) and exiting SP mode. If increasing or decreasing the AC bias for relevant color solves the spot problem, shift the AC target (SP2-001-014 through 017) by the value increased or decreased during the test.			
2001 005	AC: [K] L	*BCU	[0 to 255 / <u>170</u> / 1/step] DFU
2001 006	AC: [K] M	*BCU	
2001 007	AC: [K] H	*BCU	
2001 008	AC: [Y] L	*BCU	[0 to 255 / <u>170</u> / 1/step] DFU
2001 009	AC: [Y] M	*BCU	
2001 010	AC: [M] L	*BCU	[0 to 255 / <u>170</u> / 1/step] DFU
2001 011	AC: [M] M	*BCU	
2001 012	AC: [C] L	*BCU	[0 to 255 / <u>170</u> / 1/step] DFU
2001 013	AC: [C] M	*BCU	
2001 014	AC Target [K]	*BCU	[0 to 255 / G130: <u>79</u> , G131: <u>117</u> / 1/step] DFU
Sets the upper limit of the AC component adjustable range for black. During machine initialization and process control self-check, the AC component of the charge roller bias is automatically adjusted within the range specified by SP2-001-014 through 017.			
2001 015	AC Target [Y]	*BCU	[0 to 255 / G130: <u>78</u> , G131: <u>116</u> / 1/step] DFU
2001 016	AC Target [M]	*BCU	[0 to 255 / G130: <u>79</u> , G131: <u>117</u> / 1/step] DFU
2001 017	AC Target [C]	*BCU	[0 to 255 / G130: <u>78</u> , G131: <u>116</u> / 1/step] DFU

2103	[LD Control] LD Power Control ([Color Mode, Color], Process Speed, K or Color mode) P: Power, M: Magnification		
Adjusts the laser power by changing the current applied to LD. Laser power is automatically adjusted during process control; therefore, adjusting these data has no effect while Process Control (SP3-125 Default : ON) is activated. After deactivating Process Control with SP3-125, the values in these SP modes are used for printing.			
2103 001	P:[K] L C	*BCU	[0 to 1023 / <u>702</u> / 1/step] DFU
2103 002	P:[K] M C	*BCU	[0 to 1023 / <u>683</u> / 1/step] DFU
2103 004	P:[Y] L C	*BCU	[0 to 1023 / <u>702</u> / 1/step] DFU
2103 005	P:[Y] M C	*BCU	[0 to 1023 / <u>683</u> / 1/step] DFU
2103 007	P:[M] L C	*BCU	[0 to 1023 / <u>702</u> / 1/step] DFU
2103 008	P:[M] M C	*BCU	[0 to 1023 / <u>683</u> / 1/step] DFU
2103 010	P:[C] L C	*BCU	[0 to 1023 / <u>702</u> / 1/step] DFU
2103 011	P:[C] M C	*BCU	[0 to 1023 / <u>683</u> / 1/step] DFU

2103	[LD Control] LD Power Control ([Color Mode, Color], Process Speed, K or Color mode) P: Power, M: Magnification		
	Adjusts the laser power by changing the current applied to LD. Laser power is automatically adjusted during process control; therefore, adjusting these data has no effect while Process Control (SP3-125 Default : ON) is activated. After deactivating Process Control with SP3-125, the values in these SP modes are used for printing.		
2103 013	P:[K] L K	*BCU	[0 to 1023 / <u>702</u> / 1/step] DFU
2103 014	P:[K] M K	*BCU	[0 to 1023 / <u>683</u> / 1/step] DFU
2103 015	P:[K] H K	*BCU	[0 to 1023 / <u>683</u> / 1/step] DFU
	Main Scan Magnification ([Color], Laser Exposure Frequency)		
	Displays the result of the latest line position adjustment. Changing this affects the main scan magnification; however, this will be automatically corrected at the next line position adjustment. If a fine adjustment is required, it can be done with SP5-993-013 to 015 (this affects the way that the adjustment is done, and will be effective from the next line position adjustment). [0 to 560 / <u>280</u> / 1/2 dot/step] 1 dot = 20 μ DFU NOTE: If the line position adjustment does not work properly, the line position can be adjusted manually with this SP mode as a temporary measure. In this case, the line position adjustment needs to be disabled with SP5-993-001.		
2103 055	M:[K] 64.3/83.4MHz	*BCU	[0 to 560 / <u>280</u> / 1/2 dot/step]
2103 056	M:[Y] 64.3/83.4MHz	*BCU	1 dot = 20 μ DFU
2103 057	M:[M] 64.3/83.4MHz	*BCU	
2103 058	M:[C] 64.3/83.4MHz	*BCU	
2103 063	M:[K] 83.4MHz	*BCU	[0 to 560 / <u>280</u> / 1/2 dot/step]
2103 064	M:[Y] 83.4MHz	*BCU	1 dot = 20 μ DFU
2103 065	M:[M] 83.4MHz	*BCU	
2103 066	M:[C] 83.4MHz	*BCU	

2112	[Polygon OFF 1] Polygon Mirror Motor OFF Timing		
2112 001	Warming-up	*BCU	[0 to 60 / <u>10</u> / 1 second/step] 0: Not turned off except for Energy Saver mode
	The polygon mirror motor turns off if the machine receives no print start command for the time specified in this SP mode after receiving the print preparation command.		
2112 002	Job End	*BCU	[0 to 60 / <u>10</u> / 1 second/step] 0: Not turned off except for Energy Saver mode
	The polygon mirror motor turns off if the machine receives no print job for the time specified in this SP mode after the previous job was completed.		

2113	[Polygon OFF 2] Polygon Mirror Motor OFF	*BCU	[0 or 1 / 0 / 1 /step] Alphanumeric 0: Enable, 1: Disable
	The polygon mirror motor does not turn on until the printer enters the ready condition even after receiving the print start command. NOTE: When a user complains about high frequency noise, enabling this mode can minimize the noise.		

2150	[LD Pulse] LD Pulse Area Correction (Color, Area) FA		
	Adjusts the area correction value for color shift comparing with black. The main scan (320 mm) is divided into 12 areas. The area 1 is at front side of the machine (left side of an image) and area 12 is at rear side of the machine (right side of an image). When you decrease this value, an image shifts to the left side on a print. When you increase this value, an image shifts to the right side on a print. 1 pulse = 1/16 dot		
	2150 001	Y: Area1	*BCU
	2150 002	Y: Area2	*BCU
	2150 003	Y: Area3	*BCU
	2150 004	Y: Area4	*BCU
	2150 005	Y: Area5	*BCU
	2150 006	Y: Area6	*BCU
	2150 007	Y: Area7	*BCU
	2150 008	Y: Area8	*BCU
	2150 009	Y: Area9	*BCU
	2150 010	Y: Area10	*BCU
	2150 011	Y: Area11	*BCU
	2150 012	Y: Area12	*BCU
	2150 013	M: Area1	*BCU
	2150 014	M: Area2	*BCU
	2150 015	M: Area3	*BCU
	2150 016	M: Area4	*BCU
	2150 017	M: Area5	*BCU
	2150 018	M: Area6	*BCU
	2150 019	M: Area7	*BCU
	2150 020	M: Area8	*BCU
	2150 021	M: Area9	*BCU
	2150 022	M: Area10	*BCU
	2150 023	M: Area11	*BCU
	2150 024	M: Area12	*BCU
	2150 025	C: Area1	*BCU
	2150 026	C: Area2	*BCU
	2150 027	C: Area3	*BCU
	2150 028	C: Area4	*BCU
	2150 029	C: Area5	*BCU
	2150 030	C: Area6	*BCU
	2150 031	C: Area7	*BCU
	2150 032	C: Area8	*BCU
	2150 033	C: Area9	*BCU
	2150 034	C: Area10	*BCU
2150 035	C: Area11	*BCU	
2150 036	C: Area12	*BCU	

Service Tables

2151	[LD Mag. Pulse] LD Pulse Magnification Correction (Color) DFU		
	Adjusts the correction value for main scan magnification. When you decrease this value, an image is reduced. When you increase this value, an image is enlarged. 1 pulse = 1/16 dot		
2151 001	Bk	*BCU	[-1023 to 1023 / <u>0</u> / 1 pulse/step]
2151 002	Y	*BCU	
2151 003	M	*BCU	
2151 004	C	*BCU	

2152	[LD Control] LD Power Control (Color, Area) DFU		
	Adjusts the LD power for each area. The main scan (320 mm) is divided into 32 areas. The areas from 2 to 31 are effective image areas. The area 2 is at front side of the machine (left side of an image) and area 31 is at rear side of the machine (right side of an image).		
2152 001	Bk: Area0	*BCU	[50 to 150 / <u>108.19</u> / 0.01%/step]
2152 002	Bk: Area1	*BCU	[50 to 150 / <u>107.28</u> / 0.01%/step]
2152 003	Bk: Area2	*BCU	[50 to 150 / <u>106.32</u> / 0.01%/step]
2152 004	Bk: Area3	*BCU	[50 to 150 / <u>105.35</u> / 0.01%/step]
2152 005	Bk: Area4	*BCU	[50 to 150 / <u>104.40</u> / 0.01%/step]
2152 006	Bk: Area5	*BCU	[50 to 150 / <u>103.49</u> / 0.01%/step]
2152 007	Bk: Area6	*BCU	[50 to 150 / <u>102.65</u> / 0.01%/step]
2152 008	Bk: Area7	*BCU	[50 to 150 / <u>101.90</u> / 0.01%/step]
2152 009	Bk: Area8	*BCU	[50 to 150 / <u>101.24</u> / 0.01%/step]
2152 010	Bk: Area9	*BCU	[50 to 150 / <u>100.68</u> / 0.01%/step]
2152 011	Bk: Area10	*BCU	[50 to 150 / <u>100.23</u> / 0.01%/step]
2152 012	Bk: Area11	*BCU	[50 to 150 / <u>99.90</u> / 0.01%/step]
2152 013	Bk: Area12	*BCU	[50 to 150 / <u>99.67</u> / 0.01%/step]
2152 014	Bk: Area13	*BCU	[50 to 150 / <u>99.56</u> / 0.01%/step]
2152 015	Bk: Area14	*BCU	[50 to 150 / <u>99.55</u> / 0.01%/step]
2152 016	Bk: Area15	*BCU	[50 to 150 / <u>99.66</u> / 0.01%/step]
2152 017	Bk: Area16	*BCU	[50 to 150 / <u>100</u> / 0.01%/step]
2152 018	Bk: Area17	*BCU	[50 to 150 / <u>100</u> / 0.01%/step]
2152 019	Bk: Area18	*BCU	[50 to 150 / <u>100.55</u> / 0.01%/step]
2152 020	Bk: Area19	*BCU	[50 to 150 / <u>101.03</u> / 0.01%/step]
2152 021	Bk: Area20	*BCU	[50 to 150 / <u>101.58</u> / 0.01%/step]
2152 022	Bk: Area21	*BCU	[50 to 150 / <u>102.21</u> / 0.01%/step]
2152 023	Bk: Area22	*BCU	[50 to 150 / <u>102.89</u> / 0.01%/step]
2152 024	Bk: Area23	*BCU	[50 to 150 / <u>103.63</u> / 0.01%/step]
2152 025	Bk: Area24	*BCU	[50 to 150 / <u>104.42</u> / 0.01%/step]
2152 026	Bk: Area25	*BCU	[50 to 150 / <u>105.24</u> / 0.01%/step]
2152 027	Bk: Area26	*BCU	[50 to 150 / <u>106.10</u> / 0.01%/step]
2152 028	Bk: Area27	*BCU	[50 to 150 / <u>106.99</u> / 0.01%/step]
2152 029	Bk: Area28	*BCU	[50 to 150 / <u>107.91</u> / 0.01%/step]
2152 030	Bk: Area29	*BCU	[50 to 150 / <u>108.85</u> / 0.01%/step]
2152 031	Bk: Area30	*BCU	[50 to 150 / <u>109.82</u> / 0.01%/step]
2152 032	Bk: Area31	*BCU	[50 to 150 / <u>110.83</u> / 0.01%/step]
2152 033	Y: Area0	*BCU	[50 to 150 / <u>103.31</u> / 0.01%/step]
2152 034	Y: Area1	*BCU	[50 to 150 / <u>103.92</u> / 0.01%/step]
2152 035	Y: Area2	*BCU	[50 to 150 / <u>103.89</u> / 0.01%/step]

2152	[LD Control] LD Power Control (Color, Area) DFU		
	Adjusts the LD power for each area. The main scan (320 mm) is divided into 32 areas. The areas from 2 to 31 are effective image areas. The area 2 is at front side of the machine (left side of an image) and area 31 is at rear side of the machine (right side of an image).		
2152 036	Y: Area3	*BCU	[50 to 150 / <u>103.44</u> / 0.01%/step]
2152 037	Y: Area4	*BCU	[50 to 150 / <u>102.78</u> / 0.01%/step]
2152 038	Y: Area5	*BCU	[50 to 150 / <u>102.04</u> / 0.01%/step]
2152 039	Y: Area6	*BCU	[50 to 150 / <u>101.33</u> / 0.01%/step]
2152 040	Y: Area7	*BCU	[50 to 150 / <u>100.70</u> / 0.01%/step]
2152 041	Y: Area8	*BCU	[50 to 150 / <u>100.19</u> / 0.01%/step]
2152 042	Y: Area9	*BCU	[50 to 150 / <u>99.81</u> / 0.01%/step]
2152 043	Y: Area10	*BCU	[50 to 150 / <u>99.56</u> / 0.01%/step]
2152 044	Y: Area11	*BCU	[50 to 150 / <u>99.43</u> / 0.01%/step]
2152 045	Y: Area12	*BCU	[50 to 150 / <u>99.40</u> / 0.01%/step]
2152 046	Y: Area13	*BCU	[50 to 150 / <u>99.46</u> / 0.01%/step]
2152 047	Y: Area14	*BCU	[50 to 150 / <u>99.58</u> / 0.01%/step]
2152 048	Y: Area15	*BCU	[50 to 150 / <u>99.73</u> / 0.01%/step]
2152 049	Y: Area16	*BCU	[50 to 150 / <u>100</u> / 0.01%/step]
2152 050	Y: Area17	*BCU	[50 to 150 / <u>100</u> / 0.01%/step]
2152 051	Y: Area18	*BCU	[50 to 150 / <u>100.28</u> / 0.01%/step]
2152 052	Y: Area19	*BCU	[50 to 150 / <u>100.45</u> / 0.01%/step]
2152 053	Y: Area20	*BCU	[50 to 150 / <u>100.62</u> / 0.01%/step]
2152 054	Y: Area21	*BCU	[50 to 150 / <u>100.80</u> / 0.01%/step]
2152 055	Y: Area22	*BCU	[50 to 150 / <u>100.99</u> / 0.01%/step]
2152 056	Y: Area23	*BCU	[50 to 150 / <u>101.20</u> / 0.01%/step]
2152 057	Y: Area24	*BCU	[50 to 150 / <u>101.45</u> / 0.01%/step]
2152 058	Y: Area25	*BCU	[50 to 150 / <u>101.75</u> / 0.01%/step]
2152 059	Y: Area26	*BCU	[50 to 150 / <u>102.11</u> / 0.01%/step]
2152 060	Y: Area27	*BCU	[50 to 150 / <u>102.52</u> / 0.01%/step]
2152 061	Y: Area28	*BCU	[50 to 150 / <u>102.98</u> / 0.01%/step]
2152 062	Y: Area29	*BCU	[50 to 150 / <u>103.45</u> / 0.01%/step]
2152 063	Y: Area30	*BCU	[50 to 150 / <u>103.88</u> / 0.01%/step]
2152 064	Y: Area31	*BCU	[50 to 150 / <u>104.18</u> / 0.01%/step]
2152 065	M: Area0	*BCU	[50 to 150 / <u>112.42</u> / 0.01%/step]
2152 066	M: Area1	*BCU	[50 to 150 / <u>111.23</u> / 0.01%/step]
2152 067	M: Area2	*BCU	[50 to 150 / <u>106.63</u> / 0.01%/step]
2152 068	M: Area3	*BCU	[50 to 150 / <u>105.55</u> / 0.01%/step]
2152 069	M: Area4	*BCU	[50 to 150 / <u>104.49</u> / 0.01%/step]
2152 070	M: Area5	*BCU	[50 to 150 / <u>103.48</u> / 0.01%/step]
2152 071	M: Area6	*BCU	[50 to 150 / <u>102.56</u> / 0.01%/step]
2152 072	M: Area7	*BCU	[50 to 150 / <u>101.75</u> / 0.01%/step]
2152 073	M: Area8	*BCU	[50 to 150 / <u>101.06</u> / 0.01%/step]
2152 074	M: Area9	*BCU	[50 to 150 / <u>100.49</u> / 0.01%/step]
2152 075	M: Area10	*BCU	[50 to 150 / <u>100.06</u> / 0.01%/step]
2152 076	M: Area11	*BCU	[50 to 150 / <u>99.75</u> / 0.01%/step]
2152 077	M: Area12	*BCU	[50 to 150 / <u>99.56</u> / 0.01%/step]
2152 078	M: Area13	*BCU	[50 to 150 / <u>99.49</u> / 0.01%/step]
2152 079	M: Area14	*BCU	[50 to 150 / <u>99.52</u> / 0.01%/step]
2152 080	M: Area15	*BCU	[50 to 150 / <u>99.64</u> / 0.01%/step]
2152 081	M: Area16	*BCU	[50 to 150 / <u>100</u> / 0.01%/step]
2152 082	M: Area17	*BCU	[50 to 150 / <u>100</u> / 0.01%/step]

2152	[LD Control] LD Power Control (Color, Area) DFU		
	Adjusts the LD power for each area. The main scan (320 mm) is divided into 32 areas. The areas from 2 to 31 are effective image areas. The area 2 is at front side of the machine (left side of an image) and area 31 is at rear side of the machine (right side of an image).		
2152 083	M: Area18	*BCU	[50 to 150 / <u>100.53</u> / 0.01%/step]
2152 084	M: Area19	*BCU	[50 to 150 / <u>100.96</u> / 0.01%/step]
2152 085	M: Area20	*BCU	[50 to 150 / <u>101.45</u> / 0.01%/step]
2152 086	M: Area21	*BCU	[50 to 150 / <u>101.99</u> / 0.01%/step]
2152 087	M: Area22	*BCU	[50 to 150 / <u>102.59</u> / 0.01%/step]
2152 088	M: Area23	*BCU	[50 to 150 / <u>103.23</u> / 0.01%/step]
2152 089	M: Area24	*BCU	[50 to 150 / <u>103.91</u> / 0.01%/step]
2152 090	M: Area25	*BCU	[50 to 150 / <u>104.64</u> / 0.01%/step]
2152 091	M: Area26	*BCU	[50 to 150 / <u>105.42</u> / 0.01%/step]
2152 092	M: Area27	*BCU	[50 to 150 / <u>106.24</u> / 0.01%/step]
2152 093	M: Area28	*BCU	[50 to 150 / <u>107.12</u> / 0.01%/step]
2152 094	M: Area29	*BCU	[50 to 150 / <u>108.05</u> / 0.01%/step]
2152 095	M: Area30	*BCU	[50 to 150 / <u>109.04</u> / 0.01%/step]
2152 096	M: Area31	*BCU	[50 to 150 / <u>110.10</u> / 0.01%/step]
2152 097	C: Area0	*BCU	[50 to 150 / <u>103.04</u> / 0.01%/step]
2152 098	C: Area1	*BCU	[50 to 150 / <u>103.60</u> / 0.01%/step]
2152 099	C: Area2	*BCU	[50 to 150 / <u>103.79</u> / 0.01%/step]
2152 100	C: Area3	*BCU	[50 to 150 / <u>103.50</u> / 0.01%/step]
2152 101	C: Area4	*BCU	[50 to 150 / <u>102.86</u> / 0.01%/step]
2152 102	C: Area5	*BCU	[50 to 150 / <u>102.08</u> / 0.01%/step]
2152 103	C: Area6	*BCU	[50 to 150 / <u>101.29</u> / 0.01%/step]
2152 104	C: Area7	*BCU	[50 to 150 / <u>100.59</u> / 0.01%/step]
2152 105	C: Area8	*BCU	[50 to 150 / <u>100.03</u> / 0.01%/step]
2152 106	C: Area9	*BCU	[50 to 150 / <u>99.63</u> / 0.01%/step]
2152 107	C: Area10	*BCU	[50 to 150 / <u>99.38</u> / 0.01%/step]
2152 108	C: Area11	*BCU	[50 to 150 / <u>99.27</u> / 0.01%/step]
2152 109	C: Area12	*BCU	[50 to 150 / <u>99.28</u> / 0.01%/step]
2152 110	C: Area13	*BCU	[50 to 150 / <u>99.38</u> / 0.01%/step]
2152 111	C: Area14	*BCU	[50 to 150 / <u>99.54</u> / 0.01%/step]
2152 112	C: Area15	*BCU	[50 to 150 / <u>99.72</u> / 0.01%/step]
2152 113	C: Area16	*BCU	[50 to 150 / <u>100</u> / 0.01%/step]
2152 114	C: Area17	*BCU	[50 to 150 / <u>100</u> / 0.01%/step]
2152 115	C: Area18	*BCU	[50 to 150 / <u>100.23</u> / 0.01%/step]
2152 116	C: Area19	*BCU	[50 to 150 / <u>100.35</u> / 0.01%/step]
2152 117	C: Area20	*BCU	[50 to 150 / <u>100.45</u> / 0.01%/step]
2152 118	C: Area21	*BCU	[50 to 150 / <u>100.53</u> / 0.01%/step]
2152 119	C: Area22	*BCU	[50 to 150 / <u>100.62</u> / 0.01%/step]
2152 120	C: Area23	*BCU	[50 to 150 / <u>100.73</u> / 0.01%/step]
2152 121	C: Area24	*BCU	[50 to 150 / <u>100.89</u> / 0.01%/step]
2152 122	C: Area25	*BCU	[50 to 150 / <u>101.12</u> / 0.01%/step]
2152 123	C: Area26	*BCU	[50 to 150 / <u>101.44</u> / 0.01%/step]
2152 124	C: Area27	*BCU	[50 to 150 / <u>101.84</u> / 0.01%/step]
2152 125	C: Area28	*BCU	[50 to 150 / <u>102.32</u> / 0.01%/step]
2152 126	C: Area29	*BCU	[50 to 150 / <u>102.83</u> / 0.01%/step]
2152 127	C: Area30	*BCU	[50 to 150 / <u>103.30</u> / 0.01%/step]
2152 128	C: Area31	*BCU	[50 to 150 / <u>103.61</u> / 0.01%/step]

2201	[Dev. Bias] Development Bias ([Color], Process Speed)		
2201 001	[K] L	*BCU	Adjusts the development bias.
2201 002	[K] M	*BCU	Development bias is automatically adjusted during process control; therefore, adjusting these settings has no effect while Process Control (SP3-125 Default: ON) is activated. After deactivating Process Control with SP3-125, the values in these SP modes are used for printing. [200 to 800 / <u>500</u> / 10 V/step] DFU
2201 003	[K] H	*BCU	
2201 004	[Y] L	*BCU	
2201 005	[Y] M	*BCU	
2201 006	[M] L	*BCU	
2201 007	[M] M	*BCU	
2201 008	[C] L	*BCU	
2201 009	[C] M	*BCU	

2207	[Forced Toner] Forced Toner Supply ([Color])		
Forces toner to be supplied to the development unit. The toner supply clutch turns on for 0.7 s and off for 1.3 s.			
2207 001	[K]		[0 or 1 / <u>0</u> / 1 /step]
2207 002	[Y]		0: Not execute, 1: Execute
2207 003	[M]		
2207 004	[C]		

2208	[Toner Mode] Toner Supply Method ([Color])		
2208 001	[K]	*BCU	Selects the toner supply method.
2208 002	[Y]	*BCU	[0 to 2 / <u>1</u> / 1/step] Alphanumeric
2208 003	[M]	*BCU	0: Fixed (with the supply rates stored with SP2-208-5 to 8)
2208 004	[C]	*BCU	1: Fuzzy 2: Proportional (using the Vref values stored with SP2-224-5 to 8)
2208 005	Fixed Rate [K]	*BCU	Sets the toner supply rate used when the toner supply method (SP2-208-1 to 4) is set to 'Fixed'. [0 to 100 / <u>5</u> / 1%/step]
2208 006	Fixed Rate [Y]	*BCU	
2208 007	Fixed Rate [M]	*BCU	
2208 008	Fixed Rate [C]	*BCU	
2208 009	Upper Limit	*BCU #	Specifies the maximum possible toner supply, expressed as a percentage of the maximum amount of toner that can possibly be supplied for a sheet of paper. If too much toner is supplied to the development unit especially for black or in the low humidity condition, this may cause dirty background due to insufficient agitation. This SP mode limits the maximum possible toner supply for black and only in the low humidity condition for color. [0 to 100 / <u>63</u> / 1 %/step] DFU NOTE: The main switch must be turned off and on to effect the setting change.
2208 010	LowCoverage[K]	*BCU	Adjusts the toner supply amount (fixed rate) when making multiple prints of pages with low image ratio (coverage).
2208 011	LowCoverage[Y]	*BCU	
2208 012	LowCoverage[M]	*BCU	

2208	[Toner Mode] Toner Supply Method ([Color])		
2208 013	LowCoverage[C]	*BCU	When printing with a low image ratio, toner concentration is controlled only with Vt outputs since pixel count is not done for low image ratios. This may cause the attraction force between toner and carrier to increase, resulting in low image density on outputs. To prevent this, the machine counts the number of pixels and supplies a fixed amount of toner if the accumulated number of pixels becomes greater than the specified level. [0 to 100 / 0 / 1 %/step] DFU
2208 014	Vt Coeff[Bk]	*BCU	Specifies each constant to adjust the toner supply amount. The optimum value is specified before shipment. [0 to 2.0 / K: 0.30, Y: 0.28, C: 0.25, M: 0.25 / 0.01 %/step] DFU
2208 015	Vt Coeff[Y]	*BCU	
2208 016	Vt Coeff[M]	*BCU	
2208 017	Vt Coeff[C]	*BCU	
2208 018	Img Coeff[Bk]	*BCU	Specifies each constant to adjust the toner supply amount. The optimum value is specified before shipment. [0 to 2.0 / 0.45 / 0.01 %/step] DFU
2208 019	Img Coeff[Y]	*BCU	
2208 020	Img Coeff[M]	*BCU	
2208 021	Img Coeff[C]	*BCU	
2208 022	ImgCrctCoef[Bk]	*BCU	Specifies each constant to adjust the toner supply amount. The optimum value is specified before shipment. [0 to 2.0 / 0.10 / 0.01 %/step] DFU
2208 023	ImgCrctCoef[Y]	*BCU	
2208 024	ImgCrctCoef[M]	*BCU	
2208 025	ImgCrctCoef[C]	*BCU	

2210	[Toner Counter] Toner Supply Counter ([Color])		
	Displays the total time that the toner supply clutch has been on. This data is stored in the memory chip on each toner cartridge.		
2210 005	[K]	*BCU	[0 to 5000 / 0 / 1 second/step]
2210 006	[Y]	*BCU	
2210 007	[M]	*BCU	
2210 008	[C]	*BCU	

2212	[Toner Near/End] Toner Near End / End Detection Threshold ([Color])		
2212 001	Start [K]	*BCU	When the amount of toner amount left in the cartridge becomes less than this value, the machine starts monitoring the Vt values for toner near end detection. [0 to 1000 / 100 / 10 g/step]
2212 002	Start [YMC]	*BCU	
2212 005	Near [K]	*BCU	Specifies the threshold for toner near-end detection. The machine detects toner near-end when the following happens 10 times consecutively. $V_t > V_{ref} + \text{Threshold}$ [0 to 5.0 / 0.4 / 0.1 V/step]
2212 006	Near [YMC]	*BCU	
2212 007	End [K]	*BCU	Specifies the threshold for toner end detection. The machine detects toner end when the following happens 10 times consecutively. Then, the machine stops printing, even during a print job. $V_t > V_{ref} + \text{Threshold}$ [0 to 5.0 / 0.5 / 0.1 V/step]
2212 008	End [YMC]	*BCU	

2212	[Toner Near/End] Toner Near End / End Detection Threshold ([Color])		
2212 009	Pixel [K]	*BCU	Specifies the number of sheets with full image coverage that can be printed after toner near-end has been detected. When near-end is detected, the pixels in the images are counted. The machine detects toner end when the following happens, and the machine stops printing even during a print job. <u>Pixel count = 5 A4/LT sheets with full image coverage</u> [0 to 255 / 50 / 1 sheet/step] NOTE: The setting of SP2-212-11 has priority for deciding when to stop printing.
2212 010	Pixel [YMC]	*BCU	
2212 011	Min. Print	*BCU	Specifies the minimum number of sheets that can be printed after toner near-end has been detected. However, when the following happens 10 consecutive times, the machine stops printing even during a print job or if this guaranteed minimum has not been met. <u>Vt > Current Vref value + 1.2V or Vt > 4.8V</u> [0 to 50 / 10 / 1 sheet/step]
2212 012	sensor avg [K]	*BCU	Displays the average signal value of the toner end sensor. Printed images can be weak when the value is larger. [0 to 1 / 0 / 0.01/step] Each toner sensor detects the toner that is falling through the toner path beneath the toner cartridge. Each sensor outputs "0" when it detects toner in the toner path, or outputs "1" when it does not detect toner. The signal is "1" if toner is not passing through the path even though the toner cartridge contains toner. These signals, "0" and "1", are periodically checked and used to calculate the signal average. When enough toner is in the cartridge, the signal average is a smaller value ("0" or its vicinity). When toner is insufficient, the average is a larger value ("1" or its vicinity).
2212 013	sensor avg [Y]	*BCU	
2212 014	sensor avg [M]	*BCU	
2212 015	sensor avg [C]	*BCU	

Service Tables

2213	[T End ON/OFF] Toner End Detection ON/OFF	*BCU #	[0 to 2 / 1 / 1 /step] Alphanumeric, DFU 0: Disable (Both sensors disabled) 1: Enable (Both sensors enabled) 2: Vt Only (Toner end sensor disabled and TD sensor enabled)
Enables or disables toner near-end and end detection (if disabled, the toner supply clutch on time is still counted). Use this SP only when tests are necessary under the toner end or toner near end condition. Specify the default value after the tests. NOTE: The main switch must be turned off and on to effect the setting change.			

2223	[TD Vcnt] TD Sensor Vcnt Control		
2223 001	Initialization	*BCU	[0 or 1 / 1 / -] Alphanumeric, DFU 0: Disable, 1: Enable
Enables or disables the Vcnt Auto Adjustment when detecting a new development unit. When the machine detects a new development unit, developer initialization automatically starts. During the developer initialization, Vcnt is automatically adjusted so that Vt is within 3.0 ± 0.1V.			

2223	[TD Vcnt] TD Sensor Vcnt Control		
2223 002	Humidity	*BCU	[0 or 1 / <u>1</u> / -] Alphanumeric 0: Disable, 1: Enable
	Enables or disables the Humidity Auto Correction. This corrects the Vcnt value for the current humidity. This correction is applied to both the Vcnt values automatically adjusted during developer initialization and manually adjusted with SP2-224-1 to 4. If this correction does not work well under certain environmental conditions or due to a defective humidity sensor, deactivate the Humidity Auto Correction and adjust the Vcnt value in SP2-224-1 to 4 (by trial and error).		
2223 003	Toner Fill Up	*BCU	[0 or 1 / <u>0</u> / -] Alphanumeric, DFU 0: Deactivate, 1: Activate
	Activates or deactivates the Toner Fill Up mode, which fills up the toner supply tube with toner during developer initialization. This function is required only at machine installation. Although the default is "0", the factory setting is "1". After toner fill-up occurs during machine installation, the setting is changed to "0" automatically.		

2224	[Vcnt / Vref] Vcnt / Vref ([Color])		
Adjusts the Vcnt value manually. The value in this SP mode is effective until after the next process control self-check. To always use this value for some reason, select proportional control supply mode with SP2-208-1 to 4.			
2224 001	Vcnt [K]	*BCU#	[8 to 22.0 / <u>13.5</u> / 0.1 V/step]
2224 002	Vcnt [Y]	*BCU#	NOTE: The main switch must be turned off and on to effect the setting change.
2224 003	Vcnt [M]	*BCU#	
2224 004	Vcnt [C]	*BCU#	
Adjusts the Vref value manually. The value in this SP mode is effective until the next process control self-check. To always use this value for some reason, select proportional control supply mode with SP2-208-1 to 4.			
2224 005	Vref [K]	*BCU	[0 to 5.0 / <u>2.8</u> / 0.1 V/step]
2224 006	Vref [Y]	*BCU	
2224 007	Vref [M]	*BCU	
2224 008	Vref [C]	*BCU	

2301	[Transfer Cur.] Transfer Current ([Color Mode, Color], Paper Tray or By-pass, Simplex or Duplex/Rear, Process Speed) Paper Type -> N: Normal Paper, MT: Middle Thick Paper, TH: Thick Paper, SP: Special Paper		
	Adjusts the transfer current for each color and each print mode. NOTE: If the transfer current is increased too much, image offset may occur especially in halftone areas.		
2301 001	[K] N P S L	*BCU	[0 to 50 / <u>15</u> / 1 μ A/step]
2301 002	[K] N P S M	*BCU	[0 to 50 / <u>30</u> / 1 μ A/step] Only for G131
2301 003	[K] N P S H	*BCU	[0 to 50 / <u>30</u> / 1 μ A/step] Only for G130
2301 004	[K] N P D L	*BCU	[0 to 50 / <u>10</u> / 1 μ A/step]
2301 005	[K] N P D M	*BCU	[0 to 50 / <u>21</u> / 1 μ A/step] Only for G131
2301 006	[K] N P D H	*BCU	[0 to 50 / <u>21</u> / 1 μ A/step] Only for G130
2301 007	[K] N B S L	*BCU	[0 to 50 / <u>15</u> / 1 μ A/step]
2301 008	[K] N B S M	*BCU	[0 to 50 / <u>30</u> / 1 μ A/step] Only for G131
2301 009	[K] N B S H	*BCU	[0 to 50 / <u>30</u> / 1 μ A/step] Only for G130
2301 011	[FC K] N P S L	*BCU	[0 to 50 / <u>15</u> / 1 μ A/step]
2301 012	[FC K] N P S M	*BCU	[0 to 50 / G130: <u>23</u> , G131: <u>31</u> / 1 μ A/step]
2301 013	[FC Y] N P S L	*BCU	[0 to 50 / <u>10</u> / 1 μ A/step]
2301 014	[FC Y] N P S M	*BCU	[0 to 50 / G130: <u>16</u> , G131: <u>21</u> / 1 μ A/step]

2301	[Transfer Cur.] Transfer Current ([Color Mode, Color], Paper Tray or By-pass, Simplex or Duplex/Rear, Process Speed) Paper Type -> N: Normal Paper, MT: Middle Thick Paper, TH: Thick Paper, SP: Special Paper		
2301 015	[FC M] N P S L	*BCU	[0 to 50 / <u>10</u> / 1 μ A/step]
2301 016	[FC M] N P S M	*BCU	[0 to 50 / G130: <u>16</u> , G131: <u>21</u> / 1 μ A/step]
2301 017	[FC C] N P S L	*BCU	[0 to 50 / <u>10</u> / 1 μ A/step]
2301 018	[FC C] N P S M	*BCU	[0 to 50 / G130: <u>16</u> , G131: <u>21</u> / 1 μ A/step]
2301 019	[FC K] N P D L	*BCU	[0 to 50 / <u>9</u> / 1 μ A/step]
2301 020	[FC K] N P D M	*BCU	[0 to 50 / G130: <u>14</u> , G131: <u>18</u> / 1 μ A/step]
2301 021	[FC Y] N P D L	*BCU	[0 to 50 / <u>9</u> / 1 μ A/step]
2301 022	[FC Y] N P D M	*BCU	[0 to 50 / G130: <u>12</u> , G131: <u>16</u> / 1 μ A/step]
2301 023	[FC M] N P D L	*BCU	[0 to 50 / <u>9</u> / 1 μ A/step]
2301 024	[FC M] N P D M	*BCU	[0 to 50 / G130: <u>12</u> , G131: <u>16</u> / 1 μ A/step]
2301 025	[FC C] N P D L	*BCU	[0 to 50 / <u>9</u> / 1 μ A/step]
2301 026	[FC C] N P D M	*BCU	[0 to 50 / G130: <u>12</u> , G131: <u>16</u> / 1 μ A/step]
2301 028	[FC K] N B S L	*BCU	[0 to 50 / <u>15</u> / 1 μ A/step]
2301 029	[FC K] N B S M	*BCU	[0 to 50 / G130: <u>23</u> , G131: <u>31</u> / 1 μ A/step]
2301 030	[FC Y] N B S L	*BCU	[0 to 50 / <u>10</u> / 1 μ A/step]
2301 031	[FC Y] N B S M	*BCU	[0 to 50 / G130: <u>16</u> , G131: <u>21</u> / 1 μ A/step]
2301 032	[FC M] N B S L	*BCU	[0 to 50 / <u>10</u> / 1 μ A/step]
2301 033	[FC M] N B S M	*BCU	[0 to 50 / G130: <u>16</u> , G131: <u>21</u> / 1 μ A/step]
2301 034	[FC C] N B S L	*BCU	[0 to 50 / <u>10</u> / 1 μ A/step]
2301 035	[FC C] N B S M	*BCU	[0 to 50 / G130: <u>16</u> , G131: <u>21</u> / 1 μ A/step]
2301 037	[K] OHP L	*BCU	[0 to 50 / <u>7</u> / 1 μ A/step]
2301 038	[FC K] OHP L	*BCU	[0 to 50 / <u>10</u> / 1 μ A/step]
2301 039	[FC Y] OHP L	*BCU	[0 to 50 / <u>10</u> / 1 μ A/step]
2301 040	[FC M] OHP L	*BCU	[0 to 50 / <u>9</u> / 1 μ A/step]
2301 041	[FC C] OHP L	*BCU	[0 to 50 / <u>10</u> / 1 μ A/step]
2301 043	[K] TH R L	*BCU	[0 to 50 / <u>7</u> / 1 μ A/step]
2301 044	[FC K] TH R L	*BCU	[0 to 50 / <u>9</u> / 1 μ A/step]
2301 045	[FC Y] TH R L	*BCU	[0 to 50 / <u>9</u> / 1 μ A/step]
2301 046	[FC M] TH R L	*BCU	[0 to 50 / <u>9</u> / 1 μ A/step]
2301 047	[FC C] TH R L	*BCU	[0 to 50 / <u>9</u> / 1 μ A/step]
2301 049	[K] SP L	*BCU	[0 to 50 / <u>15</u> / 1 μ A/step]
2301 050	[K] SP M	*BCU	[0 to 50 / <u>30</u> / 1 μ A/step] Only for G131
2301 051	[K] SP H	*BCU	[0 to 50 / <u>30</u> / 1 μ A/step] Only for G130
2301 052	[FC K] SP L	*BCU	[0 to 50 / <u>15</u> / 1 μ A/step]
2301 053	[FC Y] SP L	*BCU	[0 to 50 / <u>10</u> / 1 μ A/step]
2301 054	[FC M] SP L	*BCU	[0 to 50 / <u>10</u> / 1 μ A/step]
2301 055	[FC C] SP L	*BCU	[0 to 50 / <u>10</u> / 1 μ A/step]
2301 056	[FC K] SP M	*BCU	[0 to 50 / G130: <u>23</u> , G131: <u>31</u> / 1 μ A/step]
2301 057	[FC Y] SP M	*BCU	[0 to 50 / G130: <u>16</u> , G131: <u>21</u> / 1 μ A/step]
2301 058	[FC M] SP M	*BCU	[0 to 50 / G130: <u>16</u> , G131: <u>21</u> / 1 μ A/step]
2301 059	[FC C] SP M	*BCU	[0 to 50 / G130: <u>16</u> , G131: <u>21</u> / 1 μ A/step]
2301 061	[K] TH S L	*BCU	[0 to 50 / <u>7</u> / 1 μ A/step]
2301 062	[FC K] TH S L	*BCU	[0 to 50 / <u>9</u> / 1 μ A/step]
2301 063	[FC Y] TH S L	*BCU	[0 to 50 / <u>9</u> / 1 μ A/step]
2301 064	[FC M] TH S L	*BCU	[0 to 50 / <u>9</u> / 1 μ A/step]
2301 065	[FC C] TH S L	*BCU	[0 to 50 / <u>9</u> / 1 μ A/step]
2301 067	[K] SP D L	*BCU	[0 to 50 / <u>10</u> / 1 μ A/step]
2301 068	[K] SP D M	*BCU	[0 to 50 / <u>21</u> / 1 μ A/step] Only for G131

2301	[Transfer Cur.] Transfer Current ([Color Mode, Color], Paper Tray or By-pass, Simplex or Duplex/Rear, Process Speed) Paper Type -> N: Normal Paper, MT: Middle Thick Paper, TH: Thick Paper, SP: Special Paper		
2301 069	[K] SP D H	*BCU	[0 to 50 / <u>21</u> / 1 μ A/step] Only for G130
2301 070	[FC K] SP D L	*BCU	[0 to 50 / <u>9</u> / 1 μ A/step]
2301 071	[FC Y] SP D L	*BCU	[0 to 50 / <u>9</u> / 1 μ A/step]
2301 072	[FC M] SP D L	*BCU	[0 to 50 / <u>9</u> / 1 μ A/step]
2301 073	[FC C] SP D L	*BCU	[0 to 50 / <u>9</u> / 1 μ A/step]
2301 074	[FC K] SP D M	*BCU	[0 to 50 / G130: <u>14</u> , G131: <u>18</u> / 1 μ A/step]
2301 075	[FC Y] SP D M	*BCU	[0 to 50 / G130: <u>12</u> , G131: <u>16</u> / 1 μ A/step]
2301 076	[FC M] SP D M	*BCU	[0 to 50 / G130: <u>12</u> , G131: <u>16</u> / 1 μ A/step]
2301 077	[FC C] SP D M	*BCU	[0 to 50 / G130: <u>12</u> , G131: <u>16</u> / 1 μ A/step]
2301 080	[K] MT L	*BCU	[0 to 50 / <u>15</u> / 1 μ A/step]
2301 081	[K] MT M	*BCU	[0 to 50 / <u>30</u> / 1 μ A/step] Only for G131
2301 082	[K] MT H	*BCU	[0 to 50 / <u>30</u> / 1 μ A/step] Only for G130
2301 083	[K] MT D L	*BCU	[0 to 50 / <u>10</u> / 1 μ A/step]
2301 084	[K] MT D M	*BCU	[0 to 50 / <u>21</u> / 1 μ A/step] Only for G131
2301 085	[K] MT D H	*BCU	[0 to 50 / <u>21</u> / 1 μ A/step] Only for G130
2301 088	[FC BK] MT L	*BCU	[0 to 50 / <u>15</u> / 1 μ A/step]
2301 089	[FC BK] MT M	*BCU	[0 to 50 / G130: <u>23</u> , G131: <u>31</u> / 1 μ A/step]
2301 090	[FC Y] MT L	*BCU	[0 to 50 / <u>10</u> / 1 μ A/step]
2301 091	[FC Y] MT M	*BCU	[0 to 50 / G130: <u>16</u> , G131: <u>21</u> / 1 μ A/step]
2301 092	[FC M] MT L	*BCU	[0 to 50 / <u>10</u> / 1 μ A/step]
2301 093	[FC M] MT M	*BCU	[0 to 50 / G130: <u>16</u> , G131: <u>21</u> / 1 μ A/step]
2301 094	[FC C] MT L	*BCU	[0 to 50 / <u>10</u> / 1 μ A/step]
2301 095	[FC C] MT M	*BCU	[0 to 50 / G130: <u>16</u> , G131: <u>21</u> / 1 μ A/step]
2301 096	[FC BK] MT D L	*BCU	[0 to 50 / <u>9</u> / 1 μ A/step]
2301 097	[FC BK] MT D M	*BCU	[0 to 50 / G130: <u>14</u> , G131: <u>18</u> / 1 μ A/step]
2301 098	[FC Y] MT D L	*BCU	[0 to 50 / <u>9</u> / 1 μ A/step]
2301 099	[FC Y] MT D M	*BCU	[0 to 50 / G130: <u>12</u> , G131: <u>16</u> / 1 μ A/step]
2301 100	[FC M] MT D L	*BCU	[0 to 50 / <u>9</u> / 1 μ A/step]
2301 101	[FC M] MT D M	*BCU	[0 to 50 / G130: <u>12</u> , G131: <u>16</u> / 1 μ A/step]
2301 102	[FC C] MT D L	*BCU	[0 to 50 / <u>9</u> / 1 μ A/step]
2301 103	[FC C] MT D M	*BCU	[0 to 50 / G130: <u>12</u> , G131: <u>16</u> / 1 μ A/step]
2301 104	[K] SP2 L	*BCU	[0 to 50 / <u>7</u> / 1 μ A/step]
2301 105	[FC BK] SP2 L	*BCU	[0 to 50 / <u>9</u> / 1 μ A/step]
2301 106	[FC Y] SP2 L	*BCU	[0 to 50 / <u>9</u> / 1 μ A/step]
2301 107	[FC M] SP2 L	*BCU	[0 to 50 / <u>9</u> / 1 μ A/step]
2301 108	[FC C] SP2 L	*BCU	[0 to 50 / <u>9</u> / 1 μ A/step]
2301 109	[K] SP2 D L	*BCU	[0 to 50 / <u>10</u> / 1 μ A/step]
2301 110	[FC BK] SP2 D L	*BCU	[0 to 50 / <u>12</u> / 1 μ A/step]
2301 111	[FC Y] SP2 D L	*BCU	[0 to 50 / <u>9</u> / 1 μ A/step]
2301 112	[FC M] SP2 D L	*BCU	[0 to 50 / <u>9</u> / 1 μ A/step]
2301 113	[FC C] SP2 D L	*BCU	[0 to 50 / <u>9</u> / 1 μ A/step]
2301 114	[K] SP3 L	*BCU	[0 to 50 / <u>6</u> / 1 μ A/step]
2301 115	[FC BK] SP3 L	*BCU	[0 to 50 / <u>6</u> / 1 μ A/step]
2301 116	[FC Y] SP3 L	*BCU	[0 to 50 / <u>4</u> / 1 μ A/step]
2301 117	[FC M] SP3 L	*BCU	[0 to 50 / <u>3</u> / 1 μ A/step]
2301 118	[FC C] SP3 L	*BCU	[0 to 50 / <u>4</u> / 1 μ A/step]
2301 119	[K] SP3 D L	*BCU	[0 to 50 / <u>6</u> / 1 μ A/step]
2301 120	[FC BK] SP3 D L	*BCU	[0 to 50 / <u>6</u> / 1 μ A/step]

2301	[Transfer Cur.] Transfer Current ([Color Mode, Color], Paper Tray or By-pass, Simplex or Duplex/Rear, Process Speed) Paper Type -> N: Normal Paper, MT: Middle Thick Paper, TH: Thick Paper, SP: Special Paper		
2301 121	[FC Y] SP3 D L	*BCU	[0 to 50 / <u>4</u> / 1 μ A/step]
2301 122	[FC M] SP3 D L	*BCU	[0 to 50 / <u>3</u> / 1 μ A/step]
2301 123	[FC C] SP3 D L	*BCU	[0 to 50 / <u>4</u> / 1 μ A/step]
2301 124	[K] SP3 M	*BCU	[0 to 50 / <u>9</u> / 1 μ A/step] Only for G131
2301 125	[FC BK] SP3 M	*BCU	[0 to 50 / G130: <u>10</u> , G131: <u>15</u> / 1 μ A/step]
2301 126	[FC Y] SP3 M	*BCU	[0 to 50 / G130: <u>8</u> , G131: <u>12</u> / 1 μ A/step]
2301 127	[FC M] SP3 M	*BCU	[0 to 50 / G130: <u>7</u> , G131: <u>11</u> / 1 μ A/step]
2301 128	[FC C] SP3 M	*BCU	[0 to 50 / G130: <u>8</u> , G131: <u>12</u> / 1 μ A/step]
2301 129	[K] SP3 D M	*BCU	[0 to 50 / <u>9</u> / 1 μ A/step] Only for G131
2301 130	[FC BK] SP3 D M	*BCU	[0 to 50 / G130: <u>10</u> , G131: <u>15</u> / 1 μ A/step]
2301 131	[FC Y] SP3 D M	*BCU	[0 to 50 / G130: <u>8</u> , G131: <u>13</u> / 1 μ A/step]
2301 132	[FC M] SP3 D M	*BCU	[0 to 50 / G130: <u>8</u> , G131: <u>13</u> / 1 μ A/step]
2301 133	[FC C] SP3 D M	*BCU	[0 to 50 / G130: <u>8</u> , G131: <u>13</u> / 1 μ A/step]
2301 134	[K] SP3 H	*BCU	[0 to 50 / <u>9</u> / 1 μ A/step] Only for G130
2301 135	[K] SP3 D H	*BCU	[0 to 50 / <u>9</u> / 1 μ A/step] Only for G130
2301 136	[K] SP4 L	*BCU	[0 to 50 / <u>3</u> / 1 μ A/step]
2301 137	[FC BK] SP4 L	*BCU	[0 to 50 / <u>3</u> / 1 μ A/step]
2301 138	[FC Y] SP4 L	*BCU	[0 to 50 / <u>3</u> / 1 μ A/step]
2301 139	[FC M] SP4 L	*BCU	[0 to 50 / <u>3</u> / 1 μ A/step]
2301 140	[FC C] SP4 L	*BCU	[0 to 50 / <u>3</u> / 1 μ A/step]
2301 141	[K] SP4 D L	*BCU	[0 to 50 / <u>3</u> / 1 μ A/step]
2301 142	[FC BK] SP4 D L	*BCU	[0 to 50 / <u>3</u> / 1 μ A/step]
2301 143	[FC Y] SP4 D L	*BCU	[0 to 50 / <u>3</u> / 1 μ A/step]
2301 144	[FC M] SP4 D L	*BCU	[0 to 50 / <u>3</u> / 1 μ A/step]
2301 145	[FC C] SP4 D L	*BCU	[0 to 50 / <u>3</u> / 1 μ A/step]
2301 146	[K] TH2 L	*BCU	[0 to 50 / <u>6</u> / 1 μ A/step]
2301 147	[FC BK] TH2 L	*BCU	[0 to 50 / <u>8</u> / 1 μ A/step]
2301 148	[FC Y] TH2 L	*BCU	[0 to 50 / <u>5</u> / 1 μ A/step]
2301 149	[FC M] TH2 L	*BCU	[0 to 50 / <u>5</u> / 1 μ A/step]
2301 150	[FC C] TH2 L	*BCU	[0 to 50 / <u>5</u> / 1 μ A/step]
2301 151	[K] TH3 L	*BCU	[0 to 50 / <u>6</u> / 1 μ A/step]
2301 152	[FC BK] TH3 L	*BCU	[0 to 50 / <u>6</u> / 1 μ A/step]
2301 153	[FC Y] TH3 L	*BCU	[0 to 50 / <u>4</u> / 1 μ A/step]
2301 154	[FC M] TH3 L	*BCU	[0 to 50 / <u>3</u> / 1 μ A/step]
2301 155	[FC C] TH3 L	*BCU	[0 to 50 / <u>4</u> / 1 μ A/step]
2301 156	[K] TH4 L	*BCU	[0 to 50 / <u>3</u> / 1 μ A/step]
2301 157	[FC BK] TH4 L	*BCU	[0 to 50 / <u>3</u> / 1 μ A/step]
2301 158	[FC Y] TH4 L	*BCU	[0 to 50 / <u>3</u> / 1 μ A/step]
2301 159	[FC M] TH4 L	*BCU	[0 to 50 / <u>3</u> / 1 μ A/step]
2301 160	[FC C] TH4 L	*BCU	[0 to 50 / <u>3</u> / 1 μ A/step]

2309	[Cur.Paper Size] Transfer Current - Paper Size Correction Paper Type -> N: Normal, TH: Thick, OHP, MT: Middle Thick Paper		
	Corrects the transfer current for paper size. When small paper is used for printing, the transfer current flows to the drum at the non-image areas where the transfer belt touches the OPC drum. This may cause an abnormal image due to insufficient current at the image areas. NOTE: Increase only when an abnormal image (insufficient image transfer) occurs on a small paper size. However, increasing the current too much may cause image offset.		
2309 005	N LT SEF	*BCU	[0.7 to 4.0 / <u>1.1</u> / 0.1/step]
2309 006	N A5 SEF	*BCU	[0.7 to 4.0 / <u>1.2</u> / 0.1/step]
2309 007	TH LT SEF	*BCU	[0.7 to 4.0 / <u>1.2</u> / 0.1/step]
2309 008	TH A5 SEF	*BCU	[0.7 to 4.0 / <u>1.2</u> / 0.1/step]
2309 009	OHP LT SEF	*BCU	[0.7 to 4.0 / <u>1.4</u> / 0.1/step]
2309 010	MT LT SEF	*BCU	[0.7 to 4.0 / <u>1.1</u> / 0.1/step]
2309 011	MT A5 SEF	*BCU	[0.7 to 4.0 / <u>1.2</u> / 0.1/step]
2309 014	SP3, 4 LT SEF	*BCU	[0.7 to 4.0 / <u>1.5</u> / 0.1/step]
2309 015	SP3, 4 A5 SEF	*BCU	[0.7 to 4.0 / <u>2.0</u> / 0.1/step]
2309 016	TH2, 3, 4 LT SEF	*BCU	[0.7 to 4.0 / <u>1.5</u> / 0.1/step]
2309 017	TH2, 3, 4 A5 SEF	*BCU	[0.7 to 4.0 / <u>2.0</u> / 0.1/step]

2310	[Transfer Cur.] Transfer Current - Environment Correction		
	Applies the transfer current correction if the humidity exceeds the current set value.		
2310 001	H Humidity	*BCU	[25 to 90 / <u>55</u> / 5%/step]

2402	[Transfer Ctrl] Transfer Control		
	2402 001	C Mode Posit	*BCU [0 to 500 / <u>170</u> / 10/step] DFU
	Adjusts the transfer belt position for color printing. SP2-402-1 is valid only when auto correct (SP2-402-2) is disabled.		
	2402 002	Auto Correct	*BCU [0 to 1 / <u>1</u> / 1/step] DFU Alphanumeric 0: OFF, 1: ON
Enable or disable the auto-adjustment of the transfer belt position.			
<ul style="list-style-type: none"> • When SP2-402-2 is enabled, the transfer belt position for color printing is decided in accordance with the result of the initialization processing. • SP2-402-2 validates the setting of SP2-402-1, but does not affect the setting of SP2-402-3. 			
2402 003	Bk Mode Posit	*BCU	[0 to 500 / <u>130</u> / 10/step] DFU
Adjusts the transfer belt position for monochrome printing. SP2-402-3 is always valid regardless of the setting in SP2-402-2.			

2801	[PA Roller Cur.] Paper Attraction Roller Current ([Color], Simplex or Duplex/Rear , Process Speed): Current Adjustment (Paper or By-pass): Paper Size Correction Paper Type -> TH: Thick Paper, MT: Middle Thick Paper, SP: Special Paper, OHP Adjusts the paper attraction roller current for color printing. If paper misfeeds occur at the transfer unit in color mode, check and/or adjust the paper attraction roller current. NOTE: The magenta development section is close to the paper attraction roller. Decreasing the current may not cause paper misfeed. If the current is increased too much, the following image problems may occur depending on the humidity. <u>High humidity:</u> Insufficient image transfer in magenta due to current flow to the magenta OPC drum <u>Low humidity:</u> Offset image in magenta halftone areas due to paper charged positive too much When adjusting the current with this SP mode, the value should be lower than transfer current.		
2801 001	[K] N S L	*BCU	[0 to 50 / <u>4</u> / 1 μ A/step]
2801 002	[K] N S M	*BCU	[0 to 50 / <u>8</u> / 1 μ A/step] Only for G131
2801 003	[K] N S H	*BCU	[0 to 50 / <u>8</u> / 1 μ A/step] Only for G130
2801 004	[K] N R L	*BCU	[0 to 50 / <u>4</u> / 1 μ A/step]
2801 005	[K] N R M	*BCU	[0 to 50 / <u>8</u> / 1 μ A/step] Only for G131
2801 006	[K] N R H	*BCU	[0 to 50 / <u>8</u> / 1 μ A/step] Only for G130
2801 008	[FC] N S L	*BCU	[0 to 50 / <u>1</u> / 1 μ A/step]
2801 009	[FC] N S M	*BCU	[0 to 50 / <u>1</u> / 1 μ A/step]
2801 010	[FC] N R L	*BCU	[0 to 50 / <u>5</u> / 1 μ A/step]
2801 011	[FC] N R M	*BCU	[0 to 50 / <u>10</u> / 1 μ A/step]
2801 013	[K] B TH S	*BCU	[0 to 50 / <u>5</u> / 1 μ A/step]
2801 014	[FC] B TH S	*BCU	[10 to 50 / <u>1</u> / 0.1/step]
2801 015	[K] B OHP	*BCU	[10 to 50 / <u>5</u> / 0.1/step]
2801 016	[FC] B OHP	*BCU	[10 to 50 / <u>1</u> / 0.1/step]
2801 017	[K] B TH D	*BCU	[10 to 50 / <u>5</u> / 0.1/step]
2801 018	[FC] B TH D	*BCU	[10 to 50 / <u>1</u> / 0.1/step]
2801 020	[K] SP S: L	*BCU	[10 to 50 / <u>4</u> / 0.1/step]
2801 021	[K] SP S: M	*BCU	[10 to 50 / <u>8</u> / 0.1/step] Only for G131
2801 022	[K] SP S: H	*BCU	[10 to 50 / <u>8</u> / 0.1/step] Only for G130
2801 023	[K] SP R: L	*BCU	[10 to 50 / <u>4</u> / 0.1/step]
2801 024	[K] SP R: M	*BCU	[10 to 50 / <u>8</u> / 0.1/step] Only for G131
2801 025	[K] SP R: H	*BCU	[10 to 50 / <u>8</u> / 0.1/step] Only for G130
2801 026	[FC] SP S L	*BCU	[0 to 50 / <u>1</u> / 1 μ A/step]
2801 027	[FC] SP S M	*BCU	[0 to 50 / <u>1</u> / 1 μ A/step]
2801 028	[FC] SP R L	*BCU	[0 to 50 / <u>5</u> / 1 μ A/step]
2801 029	[FC] SP R M	*BCU	[0 to 50 / G130: <u>8</u> , G131: <u>10</u> / 1 μ A/step]
2801 031	[K] MT L	*BCU	[0 to 50 / <u>4</u> / 1 μ A/step]
2801 032	[K] MT M	*BCU	[0 to 50 / <u>8</u> / 1 μ A/step] Only for G131
2801 033	[K] MT H	*BCU	[0 to 50 / <u>8</u> / 1 μ A/step] Only for G130
2801 034	[K] MT D L	*BCU	[0 to 50 / <u>4</u> / 1 μ A/step]
2801 035	[K] MT D M	*BCU	[0 to 50 / <u>8</u> / 1 μ A/step] Only for G131
2801 036	[K] MT D H	*BCU	[0 to 50 / <u>8</u> / 1 μ A/step] Only for G130
2801 038	[FC] MT L	*BCU	[0 to 50 / <u>1</u> / 1 μ A/step]
2801 039	[FC] MT M	*BCU	[0 to 50 / <u>1</u> / 1 μ A/step]
2801 040	[FC] MT D L	*BCU	[0 to 50 / <u>5</u> / 1 μ A/step]
2801 041	[FC] MT D M	*BCU	[0 to 50 / G130: <u>8</u> , G131: <u>10</u> / 1 μ A/step]
2801 042	[K] SP2 L	*BCU	[0 to 50 / <u>4</u> / 1 μ A/step]
2801 043	[K] SP2 D L	*BCU	[0 to 50 / <u>4</u> / 1 μ A/step]

2801	[PA Roller Cur.] Paper Attraction Roller Current ([Color], Simplex or Duplex/Rear, Process Speed): Current Adjustment (Paper or By-pass): Paper Size Correction Paper Type -> TH: Thick Paper, MT: Middle Thick Paper, SP: Special Paper, OHP		
2801 044	[FC] SP2 L	*BCU	[0 to 50 / <u>1</u> / 1 μ A/step]
2801 045	[FC] SP2 D L	*BCU	[0 to 50 / <u>5</u> / 1 μ A/step]
2801 046	[FC] SP3 L	*BCU	[0 to 50 / <u>1</u> / 1 μ A/step]
2801 047	[FC] SP3 D L	*BCU	[0 to 50 / <u>1</u> / 1 μ A/step]
2801 048	[K] SP3 L	*BCU	[0 to 50 / <u>1</u> / 1 μ A/step]
2801 049	[K] SP3 D L	*BCU	[0 to 50 / <u>1</u> / 1 μ A/step]
2801 050	[FC] SP3 M	*BCU	[0 to 50 / <u>1</u> / 1 μ A/step]
2801 051	[FC] SP3 D M	*BCU	[0 to 50 / <u>1</u> / 1 μ A/step]
2801 052	[K] SP3 M	*BCU	[0 to 50 / <u>1</u> / 1 μ A/step] Only for G131
2801 053	[K] SP3 D M	*BCU	[0 to 50 / <u>1</u> / 1 μ A/step] Only for G131
2801 054	[K] SP3 H	*BCU	[0 to 50 / <u>1</u> / 1 μ A/step] Only for G130
2801 055	[K] SP3 D H	*BCU	[0 to 50 / <u>1</u> / 1 μ A/step] Only for G130
2801 056	[FC] SP4 L	*BCU	[0 to 50 / <u>1</u> / 1 μ A/step]
2801 057	[FC] SP4 D L	*BCU	[0 to 50 / <u>1</u> / 1 μ A/step]
2801 058	[K] SP4 L	*BCU	[0 to 50 / <u>1</u> / 1 μ A/step]
2801 059	[K] SP4 D L	*BCU	[0 to 50 / <u>1</u> / 1 μ A/step]
2801 060	[FC] TH2 L	*BCU	[0 to 50 / <u>1</u> / 1 μ A/step]
2801 061	[K] TH2 L	*BCU	[0 to 50 / <u>1</u> / 1 μ A/step]
2801 062	[FC] TH3 L	*BCU	[0 to 50 / <u>1</u> / 1 μ A/step]
2801 063	[K] TH3 L	*BCU	[0 to 50 / <u>1</u> / 1 μ A/step]
2801 064	[FC] TH4 L	*BCU	[0 to 50 / <u>1</u> / 1 μ A/step]
2801 065	[K] TH4 L	*BCU	[0 to 50 / <u>1</u> / 1 μ A/step]

2802	[PA Cur. Size] Paper Attraction Roller Current - Paper Size Correction Paper Type -> N: Normal, TH: Thick, OHP, MT: Middle Thick Paper Adjusts the correction, depending on the paper size. When small-width paper is used for printing, the paper attraction roller current flows to the non-image areas of OPC drum where the transfer belt touches the drum. This may cause paper misfeed due to insufficient current. To increase the current by 1.5 times, set the SP mode to "15". NOTE: Adjust only when a paper misfeed occurs with a small paper size. Increasing the current too much may cause image offset in magenta halftone areas.		
2802 001	N LT SEF	*BCU	[1.0 to 4.0 / <u>1.5</u> / 0.1/step]
2802 002	N A5 SEF	*BCU	[1.0 to 4.0 / <u>2.0</u> / 0.1/step]
2802 003	TH LT SEF	*BCU	[1.0 to 4.0 / <u>1.5</u> / 0.1/step]
2802 004	TH A5 SEF	*BCU	[1.0 to 4.0 / <u>2.0</u> / 0.1/step]
2802 005	OHP LT SEF	*BCU	[1.0 to 4.0 / <u>2.4</u> / 0.1/step]
2802 007	MT LT SEF	*BCU	[1.0 to 4.0 / <u>1.5</u> / 0.1/step]
2802 008	MT A5T SEF	*BCU	[1.0 to 4.0 / <u>2.0</u> / 0.1/step]
2802 011	SP3, 4 LT SEF	*BCU	[1.0 to 4.0 / <u>1.5</u> / 0.1/step]
2802 012	SP3, 4 A5T SEF	*BCU	[1.0 to 4.0 / <u>2.0</u> / 0.1/step]
2802 013	TH2, 3, 4 LT SEF	*BCU	[1.0 to 4.0 / <u>1.5</u> / 0.1/step]
2802 014	TH2, 3, 4 A5T SEF	*BCU	[1.0 to 4.0 / <u>2.0</u> / 0.1/step]

2908	[Mirror Motor] Mirror Positioning Motor ([Color])		
	Displays the result of the latest line position adjustment. Changing this affects the mirror position, which corrects the optically skewed image; however, this will be automatically corrected at the next line position adjustment.		
	NOTE: If the line position adjustment does not work properly, the line position can be adjusted manually with this SP mode as a temporary measure. In this case, the line position adjustment needs to be disabled with SP5-993-001.		
	2908 002	[C]	*BCU [-128 to 127 / 0 / 1 pulse/step] DFU
2908 003	[M]	*BCU	
2908 004	[Y]	*BCU	

2909	[Main-scan Reg.] Main-scan Registration ([Color])		
	Displays the result of the latest line position adjustment. Changing this affects the main scan registration; however, this will be automatically corrected at the next line position adjustment. If a fine adjustment is required, it can be done with SP5-993-010 to 012 (this affects the way that the adjustment is done, and will be effective from the next line position adjustment).		
	NOTE: If the line position adjustment does not work properly, the line position can be adjusted manually with this SP mode as a temporary measure. In this case, the line position adjustment needs to be disabled with SP5-993-001.		
	1 dot = 20 μ		
	2909 001	[Y]: DOT	*BCU [-500 to 500 / 0 / 1 dot/step] DFU
	2909 002	[M]: DOT	*BCU [-500 to 500 / 0 / 1 dot/step] DFU
	2909 003	[C]: DOT	*BCU [-500 to 500 / 0 / 1 dot/step] DFU
	2909 004	[K]: DOT	*BCU [-500 to 500 / 0 / 1 dot/step] DFU
	2909 009	[Y]: 1/16DOT	*BCU [-15 to 15 / 0 / 1/16 dot/step] DFU
	2909 010	[M]: 1/16DOT	*BCU [-15 to 15 / 0 / 1/16 dot/step] DFU
	2909 011	[C]: 1/16DOT	*BCU [-15 to 15 / 0 / 1/16 dot/step] DFU
	2909 012	[K]: 1/16DOT	*BCU [-15 to 15 / 0 / 1/16 dot/step] DFU

2916	[Sub-scan Reg.] Sub-scan Registration ([Color Mode, Color], Resolution)		
	Displays the result of the latest line position adjustment. Changing this affects the sub scan registration; however, this will be automatically corrected at the next line position adjustment. If a fine adjustment is required, it can be done with SP5-993-016 to 021 (this affects the way that the adjustment is done, and will be effective from the next line position adjustment).		
	NOTE: If the line position adjustment does not work properly, the line position can be adjusted manually with this SP mode as a temporary measure. In this case, the line position adjustment needs to be disabled with SP5-993-001.		
	600 dpi: 1 dot = 40 μ , 1200dpi: 1 dot = 20 μ		
	2916 001	[K] 1200	*BCU [0 to 20000 / 7510 / 2 dot /step] DFU
	2916 002	[FC K] 1200	*BCU [0 to 20000 / 15038 / 1 dot /step] DFU
	2916 003	[FC Y] 1200	*BCU [0 to 20000 / 10402 / 1 dot /step] DFU
	2916 004	[FC M] 1200	*BCU [0 to 20000 / 1136 / 1 dot /step] DFU
	2916 005	[FC C] 1200	*BCU [0 to 20000 / 5762 / 1 dot /step] DFU
	2916 006	[K] 600	*BCU [0 to 20000 / 3755 / 2 dot /step] DFU
	2916 007	[FC K] 600	*BCU [0 to 20000 / 7519 / 1 dot /step] DFU
	2916 008	[FC Y] 600	*BCU [0 to 20000 / 5201 / 1 dot /step] DFU
	2916 009	[FC M] 600	*BCU [0 to 20000 / 568 / 1 dot /step] DFU
	2916 010	[FC C] 600	*BCU [0 to 20000 / 2881 / 1 dot /step] DFU

2919	[MScan Lgth Det] Main-scan Length Detection		
	Enables or disables the main-scan length detection.		
2919 001	OFF/ON	*BCU	[0 or 1 / <u>1</u> / -] Alphanumeric 0: Disable, 1: Enable
2919 002	Interrupt time 1 Non interrupt during a job (default on)	*BCU	[0 to 999 / <u>1</u> / 1 second/step]
2919 003	Interrupt time 2 Interrupt during a job (default on)	*BCU	[0 to 999 / <u>0</u> / 1 second/step]

2920	[LD Pulse]		
	Enables or disables the LD pulse area correction (SP2-150). When the "Disable" is selected, the setting values of the SP2-150 become 0. NOTE: Set the "Disable" after replacing the laser optics-housing unit.		
2920 001	OFF/ON	*BCU	[0 or 1 / <u>1</u> / -] Alphanumeric 0: Disable, 1: Enable

2994	[Mscan Reg Cor] Main-scan Registration Correction ([Color]) Not used. DFU		
2994 001	[Y]	*BCU	[-128 to 127 / <u>0</u> / 1 dot/step] DFU
2994 002	[M]	*BCU	[-128 to 127 / <u>1</u> / 1 dot/step] DFU
2994 003	[C]	*BCU	[-128 to 127 / <u>1</u> / 1 dot/step] DFU
2994 004	[K]	*BCU	[-128 to 127 / <u>0</u> / 1 dot/step] DFU

2995	[Motor Reset] Mirror Positioning Motor Reset	*BCU	
	Rotates the mirror position motors (CMY) by 250 pulses clockwise; then by 125 pulses counterclockwise. This moves the mirrors back to the initial position. Then, the settings of SP2-908-002 to 004 are reset to 0. When the line position adjustment fails, it is one of possible causes when the mirror position motor locks. Performing this SP mode can move the mirrors back to the original position if it locks. Then, do the forced line position adjustment (SP5-993-002).		

SP3-XXX (Process)

3005	[TD Initial] TD Sensor Initialization ([Color])		
3005 001	[K]		Initializes the developer. DFU Press the Enter key to execute the initialization after the machine asks "Execute?"
3005 002	[Y]		
3005 003	[M]		
3005 004	[C]		
3005 005	[All Color]		
3005 006	Result	*BCU	[1 to 9 / - / -] 1: Success, 2 to 9: Failure
Displays the developer initialization result. All colors are displayed. Values show in the order K Y C M. e.g., 1 1 2 1: Initialization of Cyan failed but the others succeeded See the troubleshooting section for details.			

3006	[Vcnt Initial] Vcnt Initial Setting Display ([Color])		
3006 001	[K]	*BCU	Displays the initial Vcnt value. [0 to 24.0 / - / 0.1 V/step]
3006 002	[Y]	*BCU	
3006 003	[M]	*BCU	
3006 004	[C]	*BCU	
3006 005	[Bk]	*BCU	Adjusts the target Vref value for the initial setting. [0 to 24.0 / <u>3.0</u> / 0.1 V/step]
3006 006	[Y]	*BCU	
3006 007	[M]	*BCU	
3006 008	[C]	*BCU	

3007	[TD Vcnt] TD sensor Current Vcnt Value ([Color])		
Displays the current Vcnt value.			
3007 001	Vcnt Current: K	*BCU	[0 to 24.0 / - / 0.1 V/step]
3007 002	Vcnt Current: Y	*BCU	
3007 003	Vcnt Current: M	*BCU	
3007 004	Vcnt Current: C	*BCU	
3007 005	Vcnt Mode Select	*BCU	[0 or 1 / <u>1</u> / -] 0: Disable, 1: Enable
Enables or disables the Vcnt correction.			
3007 006	Vcnt Max	*BCU	[0 to 4 / <u>1.7</u> / 0.1 V/step]
Adjusts the maximum Vcnt at developer initialization			
3007 007	Vcnt Min	*BCU	[0 to 4 / <u>2.7</u> / 0.1 V/step]
Adjusts the minimum Vcnt at developer initialization			
3007 008	Vcnt SelfChk Max	*BCU	[0 to 5.4 / <u>1.7</u> / 0.1 V/step]
Adjusts the maximum Vcnt at process control self check			
3007 009	Vcnt SelfChk Min	*BCU	[0 to 5.4 / <u>2.7</u> / 0.1 V/step]
Adjusts the minimum Vcnt at process control self check			

3008	[Temp Humi] Temperature/ Humidity Display		
3008 001	Humidity	*BCU	[0 to 100 / - / 1%/step]
Displays the humidity measured by the humidity/temperature sensor.			
3008 002	Temp 1	*BCU	[0 to 100 / - / 1%/step]
Shows the temperature measured by thermistor 2 on the laser optics unit.			
3008 003	Temp 2	*BCU	[0 to 100 / - / 1%/step]
Shows the temperature measured by thermistor 1 on the laser optics unit			

3107	[Vsg Display] Vsg Display (Front or Rear)		
3107 001	Vsg F	*BCU	[0.00 to 5.00 / - / 0.01V/step]
	Displays the Vsg value of the front ID sensor. Vsg is normally 4.0 ± 0.5 V. If Vsg is out of the adjustment range and this is detected 3 times consecutively, it leads to SC385.		
3107 002	LED Current F	*BCU	[0 to 1023 / - / 1]
	Displays the ID sensor LED current adjusted during Vsg adjustment.		
3107 003	Vsg C	*BCU	[0.00 to 5.00 / - / 0.01V/step]
	Displays the Vsg value of the center ID sensor. Vsg is normally 4.0 ± 0.5 V. If Vsg is out of the adjustment range and this is detected 3 times consecutively, it leads to SC385.		
3107 004	LED Current C	*BCU	[0 to 1025 / - / 1]
	Displays the ID sensor LED current adjusted during Vsg adjustment.		
3107 005	Vsg R	*BCU	[0.00 to 5.00 / - / 0.01V/step]
	Displays the Vsg value of the rear ID sensor. Vsg is normally 4.0 ± 0.5 V. If Vsg is out of the adjustment range and this is detected 3 times consecutively, it leads to SC385.		
3107 006	LED Current R	*BCU	[0 to 1025 / - / 1]
	Displays the ID sensor LED current adjusted during Vsg adjustment.		
3107 007	Vsg avg bk	*BCU	[0.00 to 5.00 / - / 0.01V/step]
	Displays the average black Vsg value of the center ID sensor.		

3120	[Dev. g Target] Development Gamma Target ([Color])		
	Adjusts the development gamma by changing the Vref value used for toner density control. Vref is automatically corrected so that the gamma measured during the process control self-check becomes "the value set with this SP mode ± 0.15 "		
3120 001	Set [K]	*BCU	[0.5 to 1.00 / <u>0.7</u> / 0.01 mg/cm ² /KV / step] DFU
3120 002	Set [Y]	*BCU	
3120 003	Set [M]	*BCU	
3120 004	Set [C]	*BCU	
3120 005	Display [K]	*BCU	Displays the current development gamma value.
3120 006	Display [Y]	*BCU	
3120 007	Display [M]	*BCU	
3120 008	Display [C]	*BCU	
3120 009	Mode Select	*BCU	Sets the condition for the development gamma correction. [0 to 3 / <u>1</u> / 1 /step] Alphanumeric 0: Non 1: Humidity 2: Dev. Rotation 3: All

3121	[Dev. g Display] Development Gamma Display ([Color])		
	Displays the development gamma measured during the process control self-check.		
3121 001	[K]	*BCU	[0 to 10.00 / - / 1 mg/cm ² /KV /step]
3121 002	[Y]	*BCU	Normal Range: 1.00 to 2.00
3121 003	[M]	*BCU	
3121 004	[C]	*BCU	

3122	[Vk Display] Vk Display ([Color])		
3122 001	[K]	*BCU	Displays the current Vk value.
3122 002	[Y]	*BCU	[-255 to 255 / - / 1 V/step]
3122 003	[M]	*BCU	Normal Range: -50 to 50
3122 004	[C]	*BCU	

3123	[Vref Display] Current Vref Display ([Color])		
3123 001	[K]	*BCU	Displays the current Vref value.
3123 002	[Y]	*BCU	[2.0 to 4.0 / - / 0.1V/step]
3123 003	[M]	*BCU	
3123 004	[C]	*BCU	

3125	[Process Contr.] Process Control		
3125 001	ON/OFF	*BCU	[0 or 1 / <u>1</u> / 1/step] Alphanumeric 0: OFF (Use the fixed values for VD, VL and VB set with SP2-001, SP2-103, and SP2-201.) 1: ON Enables or disables process control.
3125 002	LD Control	*BCU	[0 to 2 / <u>1</u> / 1/step] Alphanumeric 0: Fixed (at the value in SP2-103) 1: Process Control 2: LD Power Selects the LD control mode.
3125 003	Auto TD Adj.	*BCU	[0 to 3 / <u>0</u> / 1/step] Alphanumeric 0: Disable 1: Initial 2: Job end 3: Initial & Job end Specifies when to perform the Auto Toner Density Adjustment. When performing the Auto Toner Density Adjustment, the machine supplies or consumes toner so that the development gamma is within ± 0.15 of the gamma target. <i>Change if the user complains of toner density fluctuations. Before changing the setting away from 0, check the result of the forced TD adjustment (SP3-126-2). If the problem is persistent, then change to 1, 2, or 3. However, the machine takes several minutes to do this adjustment.</i>
3125 004	ACC	*BCU	[0 to 2 / <u>2</u> / 1/step] Not used 0: Disable 1: Process Control 2: Auto TD Adj Enables or disables the process control self-check before printing the ACC pattern. NOTE: If color balance changes during multi-copy runs after ACC is performed, select 1 or 2. Setting 2 can precisely adjust the image density; however, it takes about 6 minutes. Select 1 or 2 depending on the user's requirement.
3125 005	TD Adj. Cndtn	*BCU	[0 to 1 / <u>1</u> / 1/step] Alphanumeric 0: Unconditional, 1: Conditional Specifies whether temperature and humidity are taken into account when deciding the timing of the auto toner density adjustment (described in SP3-125-3). Timing for the auto toner density adjustment is determined by the setting of SP3-125-3. In addition, if SP 3-125-5 is set to "1", the auto toner density adjustment is done when the temperature and humidity meet specified conditions (same conditions as used for transfer current correction). Specify "1" when both temperature and humidity are both high or low.

3125	[Process Contr.] Process Control		
3125 006	TD Adj. Times	*BCU	[1 to 3 / <u>3</u> / 1/step]
	Limits the number of auto toner density adjustments. The auto toner density adjustment consists of three steps: detecting the development gamma, supplying or consuming toner, and detecting the development gamma again. When these three steps are all complete, it means a single auto toner density adjustment is complete.		
3125 007	Temperature	*BCU	[0 to 200 / <u>60</u> / 1°C /step]
	Adjusts the fusing temperature threshold for process control execution when the main switch is turned on.		
3125 008	Pic Vb Max	*BCU	[600 to 800 / <u>680</u> / 10 V /step]
	Adjusts the development bias upper limit.		
3125 009	Pic Vb Min	*BCU	[200 to 400 / <u>300</u> / 10 V /step]
	Adjusts the development bias lower limit.		

3126	[Forced SelfChk] Forced Self-check		
3126 001	Forced SelfChk		Performs a forced process control self-check.
3126 002	Forced TD Adj.		Performs a forced auto toner density adjustment.

3902	[Pntr. Display] Pointer Table Display ([Color])								
3902 001	Printer [K]	*BCU	Displays the number in the pointer table that was selected during the latest process control self-check.						
3902 002	Printer [Y]	*BCU							
3902 003	Printer [M]	*BCU							
3902 004	Printer [C]	*BCU					[1 to 30 / - / 1/step]		
		Vc	Vb	LD Power		Vc	Vb	LD Power	
	1:	300V	100V	668		16:	600V	400V	660
	2:	320V	120V	668		17:	620V	420V	656
	3:	340V	140V	668		18:	640V	440V	652
	4:	360V	160V	668		19:	660V	460V	648
	5:	380V	180V	668		20:	680V	480V	644
	6:	400V	200V	668		21:	700V	500V	640
	7:	420V	220V	668		22:	720V	520V	636
	8:	440V	240V	668		23:	740V	540V	632
	9:	460V	260V	668		24:	760V	560V	628
	10:	480V	280V	668		25:	780V	580V	624
	11:	500V	300V	668		26:	800V	600V	620
	12:	520V	320V	668		27:	820V	620V	620
	13:	540V	340V	668		28:	840V	640V	620
	14:	560V	360V	668		29:	860V	660V	620
	15:	580V	380V	664		30:	880V	680V	620

3903	[M/A Target] M/A Target ([Color])		
	Adjusts the M/A (M ass per A rea, mg/cm ²) value used during the process control self-check. Adjusting this changes the development bias. This causes the solid ID to increase or decrease. If developer capability causes an ID problem, toner density needs to be adjusted with SP3-120-1 to 4, depending on the color.		
3903 001	Printer [K]	*BCU	[0 to 1.50 / <u>0.40</u> / 0.01 mg/cm ² /step] DFU
3903 002	Printer [Y]	*BCU	
3903 003	Printer [M]	*BCU	
3903 004	Printer [C]	*BCU	

3904	[M/A for LD] M/A Target for LD Correction ([Color])		
	Adjusts the M/A value used during the LD correction mode. This value is effective when SP3-125-2 "LD Control" is set to "LD Power". Adjusting this data effects the image reproduction especially in highlight areas.		
3904 001	Printer [K]	*BCU	[0 to 1.00 / <u>0.12</u> / 0.01 mg/cm ² /step] DFU
3904 002	Printer [Y]	*BCU	
3904 003	Printer [M]	*BCU	
3904 004	Printer [C]	*BCU	

3905	[M/A Target] M/A Target for Paper Interval Process Control		
3905 001	Intrvl [K]	*BCU	[0 to 1.50 / <u>0.25</u> / 0.01 mg/cm ² /step] DFU
3905 002	Intrvl [Y]	*BCU	Adjusts the target amount of each toner on paper sheets. These values are optimized before shipment. Do not change the values. Changing these values does not affect toner density on paper sheets.
3905 003	Intrvl [M]	*BCU	
3905 004	Intrvl [C]	*BCU	
3905 005	Intrvl [K]	*BCU	
3905 006	Intrvl [Y]	*BCU	Displays the amount of each toner on the paper. A problem may have occurred in the printer engine if the value is high or low (i.e., if the difference between SP3-905-1/2/3/4 and SP3-905-5/6/7/8 is larger than ±0.03 mg/cm ²). Possible problems: Defective TD sensor, defective ID sensor, toner near-end (if the value is lower than the target), defective toner supply mechanism
3905 007	Intrvl [M]	*BCU	
3905 008	Intrvl [C]	*BCU	
3905 009	Gamma Correct [K]	*BCU	
3905 010	Gamma Correct [Y]	*BCU	
3905 011	Gamma Correct [M]	*BCU	
3905 012	Gamma Correct [C]	*BCU	

3906	[PC SelfChk] Process Control Self-checks		
3906 001	Job End	*BCU	[0 to 999 / <u>200</u> / 1 sheet/step]
	Specifies the execution timing of the job end process control self-check. The job end process control self-check is automatically done after a job is completed when 200 prints have been made since the last self-check. The counter for the job end process control self-check resets when one of the following process control self-checks is done. <ul style="list-style-type: none"> • Initial • Interval: Interrupt • Non-use Time • During Toner End When K prints are made, the number of prints is calculated with the K coefficient in SP3-906-5.		
3906 002	Interrupt	*BCU	[0 to 999 / <u>0</u> / 1 sheet /step]
	Specifies the execution timing of the interrupt process control self-check. The interrupt process control self-check is automatically done if the number of prints in the job exceeds the number set in this SP mode. When the print job is completed, the counter is reset, even if the interrupt self check did not occur. When K prints are made, the number of prints is calculated with the K coefficient in SP3-906-5.		

3906	[PC SelfChk] Process Control Self-checks		
3906 003	Non-use Time 1	*BCU	[0 to 999 / <u>0</u> / 1 sheet /step] 0: Disable
	Specifies the executing timing of the non-use time process control self-check. The non-use time process control self-check is automatically done after the number of prints set with this SP mode have been made and no prints have been made for the time set with SP3-906-4 since the last print job. If the conditions are met, the self-check will be done after the print job is completed. The counter is reset when the initial process control self-checks is done or when a print is made.		
3906 004	Non-use Time 2	*BCU	[0 to 2550 / <u>480</u> / 10 minutes/step] 0: Disable
	Specifies the executing timing of the non-use time process control self-check.		
3906 005	K Coefficient	*BCU	[0 to 1.00 / <u>1.00</u> / 0.01/step] DFU
	Sets the coefficient to calculate the counter value for black-and-white prints. With the default setting (100), counters used for process control count up by 1 when 1 black-and-white print has been made.		
3906 006	Pow On Int Time	*BCU	[0 to 24 / <u>6</u> / 1 hour /step] 0: Disable
	Specifies the executing timing of the initial process control self-check when the machine recovers from energy saver mode or auto off mode. The initial process control self-check is cancelled during the time set with this SP.		

3910	[Vmin Display] Vmin Display ([Color])		
3910 001	[K]	*BCU	[0 to 2.00 / <u>0</u> / 0.01/step]
	Displays the current Vmin value for K		
3910 002	[Color]	*BCU	[0 to 2.00 / <u>0</u> / 0.01/step]
	Displays the lowest current Vmin value for the colors (CMY).		

3911	[Vt Display Cur] Vt Current Display ([Color])		
3911 001	[K]	*BCU	Displays the current Vt value. [0.0 to 5.0 / - / 0.1V/step]
3911 002	[Y]	*BCU	
3911 003	[M]	*BCU	
3911 004	[C]	*BCU	

3912	[Vt Display Ave] Vt Average Display ([Color])		
3912 001	[K]	*BCU	Displays the average Vt value. [0.0 to 5.0 / - / 0.1V/step]
3912 002	[Y]	*BCU	
3912 003	[M]	*BCU	
3912 004	[C]	*BCU	

3913	[T. Supply Time] Toner Supply Time Display ([Color])		
3913 001	[K]	*BCU	Displays the toner supply clutch on time for the most recent page.
3913 002	[Y]	*BCU	
3913 003	[M]	*BCU	[0 to 5000 / - / 1 ms/step]
3913 004	[C]	*BCU	

3920		[OPC Refresh]	
3920 001	Temperature	*BCU	[10 to 30 / <u>25</u> / 1°C /step]
	<p>This SP determines the temperature threshold for determining whether refresh mode is done just after the machine is switched on. The charge roller generates NOx (nitrogen oxides), and these contaminate the OPC drum surface and may cause a smeared image. Just after the main switch is turned on, if the temperature measured by both the thermistor located at the right side on the laser optics housing unit and the temperature/humidity sensor is greater than the temperature specified in this SP mode, refresh mode is done before initial process control. During refresh mode, toner is developed on the OPC with 50V development potential and cleaned to remove NOx. This cycle is repeated a few times.</p>		
3920 002	Humidity	*BCU	[10 to 90 / <u>75</u> / 1%/step]
	<p>This SP determines the humidity threshold for determining whether refresh mode is done just after the machine is switched on. Just after the main switch is turned on, if the humidity measured by the temperature/humidity sensor is greater than the humidity specified in this SP mode, refresh mode is done before the initial process control self-check.</p>		
3920 003	Prints	*BCU	[10 to 2550 / <u>200</u> / 10 prints/step]
	<p>Specifies how often refresh mode is done. When the total number of prints since the last refresh mode exceeds the number specified in this SP mode, refresh mode is done before the job end process control self-check.</p>		
3920 004	Mode Set	*BCU	[0 to 2 / <u>0</u> / 1/step] Alphanumeric 0: Disable 1: Mode 1 (Done at power on and toner end recovery) 2: Mode 2 (Done at power on, toner end recovery, and after the specified number of prints.)
	<p>Enables/disables refresh mode. NOTE: Refresh mode is done during the toner end recovery self-check after a new toner cartridge is installed.</p>		
3920 005	Forced		
	<p>Executes a forced refresh mode. Use this mode when the image is smeared. It takes about 1 minute.</p>		
3920 006	Auto Tnr Ref (Auto Toner Refresh)	*BCU	[0 or 1 / <u>1</u> / -] 0: Disable, 1: Enable
	<p>Performs a toner refresh during the OPC refresh mode by changing the development bias from 50V to 400V. Enable this SP mode when dirty background and/or firefly spots appear intermittently on prints with a low image area ratio. While making prints with a low image area ratio, developer is agitated with less toner supplied. This may cause the toner-carrier attraction force to increase or toner to coagulate. This sometimes causes firefly spots or dirty background when a large amount of toner is supplied. NOTE: When enabling this SP mode, the following SP modes should be changed. SP3-906-001 Job End Process Control Self-check 200 (Default) -> 100 SP3-920-003 OPC Refresh Mode / Prints 200 (Default) -> 100</p>		

3921	[Forced Tnr Ref] Forced Toner Refresh		
	Perform forced toner refresh mode. When the developer has deteriorated or when prints are made in a very low humidity condition, dirty background may appear continuously. When this kind of dirty background appears, check whether or not the development gamma is within the target (SP3-120 and 121). If the development gamma is not within the target, do this SP mode. The machine automatically does the toner refresh mode in the following sequence. <ol style="list-style-type: none"> 1. Consumes toner in the development unit without toner supply until toner end is detected 2. Starts toner recovery mode. 3. Starts process control self-check. <p>NOTE: If toner is drastically consumed for a short time, this may cause carrier to flow out. To prevent this, toner is consumed over a long period of time.(It takes about 20 minutes to complete this toner refresh mode).</p>		
	3921 001	Bk	
3921 002	All Color		

3922	[OPC Refresh2]	*BCU	[0 ~ 2 / 1 / 1 /step] 0: Disable (OPC refresh is not executed.) 1: Low Coverage (OPC refresh is executed after an output of low coverage ratio.) 2: All time (OPC refresh is executed after every job.)
	Specifies when the OPC refresh is executed for CMY drums, which forcibly creates a temporary 15mm-wide toner line on the drum surface by applying the development bias (200V) and turning on the development clutch at the end of a job. Note that this OPC refresh is a separate process from the one controlled by SP3-920 and 3-921.		

3923	[Trans P Pat] Line Pattern between transferred papers.		
	Generates line patterns between sheets on the transfer belt during a print job to prevent the transfer-cleaning blade from rolling up.		
3923 001	Temp	*BCU	[0 to 3 / 1 / 1 /step] 0: No Line 1: Input HH 2: Input HH, MM 3: Input All HH (high temperature, high humidity) MM (middle temperature, middle humidity)
3923 002	P width (Paper width)	*BCU	[1 or 2 / 1 / -] 1: <= LTT (LT lengthwise or less) 2: All
3923 003	Pat Interval	*BCU	[0 to 255 / 0 / 1 /step]
If this SP is set to 'n', line patterns are generated once per "(n +1)" x 4 intervals.			

3924	[P Pat Interval] Process Control Pattern Interval		
	Vref compensation is skipped during a print job.		
3924 001	Pat Interval	*BCU	[0 to 10 / 0 / 1 /step]
	If this SP is set to 'n', Vref compensation is skipped "n" times per "(n + 1)" times. This SP is activated only when SP3-924-002 is set to "0".		
3924 002	Mode Set	*BCU	[0 to 2 / 1 / 1 /step] Alphanumeric 0: Fixed (All) 1: Fuzzy (All) 2: Fuzzy (LL/MM) 3: Fuzzy (LL) LL (low temperature, low humidity) MM (middle temperature, middle humidity)
	<p>Selects the condition for V_{REF}.compensation.</p> <p>Fixed (ALL): The process control pattern is created on the transfer belt at times specified with SP3-924-001.</p> <p>Fuzzy (All): At multiple printing jobs, the process control pattern is created on the transfer belt as followings.</p> <ol style="list-style-type: none"> 1) Created at every paper when the machine gets a 1 to 8 prints job. 2) Created 4 times and then skipped 4 times when the machine gets a 9 to 32 prints job. 3) Created 4 times and then skipped 8 times when the machine gets a 33 to 68 prints job. 4) Created 4 times and then skipped 12 times when the machine gets a over 69 prints job. <p>However, the process control pattern is created at every paper if the machine gets a job, which has over 30% image ratio.</p> <p>Fuzzy (LL/MM): The process control pattern is created as follow "Fuzzy (All)" condition only when the environment meets the LL/MM condition. Except the LL/MM condition, it is created at every paper.</p> <p>Fuzzy (LL): The process control pattern is created as follow "Fuzzy (All)" condition only when the environment meets the LL condition. Except the LL condition, it is created at every paper.</p>		

Service Tables

3975	[P Ctrl Result] Process Control Self-check Result		
	*BCU	[0 to 9999 / - / 1/step]	
<p>Displays the result of the latest process control self-check.</p> <p>All colors are displayed. The results are displayed in the order "K Y C M"</p> <p>e.g., 1 1 9 1: The self-check for Cyan failed but the others were successful</p> <p>See the troubleshooting section for details.</p>			

SP5-XXX (Mode)

5024	[mm/inch Display]	*CTL	0: mm (Europe/Asia), 1: inch (USA)
	Display units (mm or inch) for custom paper sizes.		

5045	[Counter Method]	*CTL	[0 or 1 / 1 / -] 0: Developments, 1: Prints
	Selects the counting method if the meter charge mode is enabled with SP5-930-001. You can change the setting only one time.		

5051	[Toner Refill Displ] Toner Refill Detection Display		
	Enables or disables the toner refill detection display.		
5051 1	Toner Refill Displ	*CTL	[0 or 1 / 0 / -] 0: enable 1: disable

5104	[Double Count]	*CTL	[0 to 2 / 0 / 1 /step] 0: No, 1: YES, 2: Yes except By-pass
	Specifies whether the counter is double clicked for A3/DLT size prints.		

5131	[Paper Size]	*BCU	
	<ul style="list-style-type: none"> • DOM: Japan • USA: North America • ERP: Europe The default setting changes for each area.		

5150	[Bypass Length Setting]	*CTL	[0 or 1 / 0 / -] Alphanumeric 0: OFF, 1: ON
	Lets or does not let the by-pass tray feed extra long paper (up to 1260 mm).		

5179	[Print By-pass]	*CTL	[0 or 1 / 0 / -] 0: OFF, 1: ON (displays error message)
	Enables or disables the alert function for the paper feed misdirection at the by-pass printing. This function shows an error message when a paper jam occurs because the paper feed direction is different from the one that has been set with UP mode.		

5302	[Set Time]	*CTL#	[-1440 to 1440 / 60 / 1 min./step] Not used
	Adjusts the RTC (real time clock) time setting for the local time zone. Examples: For Japan (+9 GMT), enter 540 (9 hours x 60 min.) NA :-300 (Montreal) EU :+ 60 (Paris) CH :+480 (Beijing) TW :+480 (Taipei) AS :+480 (Hong Kong)		

5307	[Summer Time]		
5307 001	Setting	*CTL#	[0 to 1 / NA, EU, ASIA / 1 /step] 0: Disabled 1: Enabled NA and EUR: 1, ASIA: 0
	Enables or disables the summer time mode. NOTE: Make sure that both SP5-307-3 and 4 are correctly set. Otherwise, this SP is not activated even if this SP is set to "1".		
5307 003	Rule Set (Start)	*CTL#	
	Specifies the start setting for the summer time mode. There are 8 digits in this SP. For months 1 to 9, the "0" cannot be input in the first digit, so the eight-digit setting for -2 or -3 becomes a seven-digit setting. 1st and 2nd digits: The month. [1 to 12] 3rd digit: The week of the month. [1 to 5] 4th and 5th digits: The day of the week. [0 to 6 = Sunday to Saturday] 6th digit: The hour. [00 to 23] 7th digit: The length of the advanced time. [0 to 9 / 1 hour /step] 8th digit: The length of the advanced time. [0 to 5 / 10 minutes /step] For example: 3500010 (EU default) The timer is advanced by 1 hour at am 0:00 on the 5th Sunday in March <ul style="list-style-type: none"> The digits are counted from the left. Make sure that SP5-307-1 is set to "1". 		
5307 004	Rule Set (End)	*CTL#	
	Specifies the end setting for the summer time mode. There are 8 digits in this SP. 1st and 2nd digits: The month. [1 to 12] 3rd digit: The week of the month. [0 to 5] 4th digit: The day of the week. [0 to 7 = Sunday to Saturday] 5th and 6th digits: The hour. [00 to 23] The 7th and 8 digits must be set to "00". <ul style="list-style-type: none"> The digits are counted from the left. Make sure that SP5-307-1 is set to "1". 		

Service Tables

5404	[UCodeCtrClr] Use Code Counter Clear		
	Clears all counters for users.		

5501*	[PM Alarm]	*CTL	[0 to 9999 / 0 / 1/step] 0: Disables the PM alarm
	Sets the PM alarm level. A PM alarm is made when this condition occurs: PA x 1000 = PC, where PA is the value set in SP5-501 and PC is the value in the PM counter. This SP is for use with NRS.		

5504	[Jam Alarm]	*CTL	[0 to 3 / <u>3</u> / 1/step] 3: 6K, 2: 3K, 1: 1.5K, 0: Disables the jam alarm
	Sets the jam alarm level. If a paper jam occurs, the jam alarm counter increases by +1. If no paper jam occurs while the set number of paper is output, the jam alarm counter decreases by -1. The jam alarm occurs when the jam alarm counter gets to +10. This SP is for use with NRS.		

5505	[Error Alarm]	*CTL	[0 to 255 / G130: <u>25</u> , G131: <u>35</u> / 1/step] 0: Disables the PM alarm
	Sets the error alarm level. If an SC code occurs, the error alarm counter increases by +1. If no SC code occurs while the set number of paper is output, the jam alarm counter decreases by -1. The error alarm occurs when the error alarm counter reaches +5. This SP is for use with NRS.		

5507	[Supply Alarm]		
Enables or disables the supply alarm.			
5507 001	Paper Supply Alarm	*CTL	[0 to 1 / <u>0</u> / 1/step] Alphanumeric
5507 002	Staple Supply Alarm	*CTL	0: OFF, 0: ON
5507 003	Toner Supply Alarm	*CTL	
Sets the supply alarm level. A supply alarm counter increases by +1 when a sheet of the related size is used. The supply alarm occurs when one of the supply alarm counters gets to the set value. This SP is for use with NRS.			
5507 128	Interval: Others	*CTL	[250 to 10000 / <u>1000</u> / 1/step]
5507 132	Interval: A3	*CTL	
5507 133	Interval: A4	*CTL	
5507 134	Interval: A5	*CTL	
5507 141	Interval: B4	*CTL	
5507 142	Interval: B5	*CTL	
5507 160	Interval: DLT	*CTL	
5507 164	Interval: LG	*CTL	
5507 166	Interval: LT	*CTL	
5507 172	Interval: HLT	*CTL	

5515	[SC Call Setting]		
Enables or disables the SC call setting.			
5515 001	SC Call Setting	*CTL	[0 or 1 / 0 / -] 0: Enable, 1: Disable This SP is activated only when CSS or NRS is enabled.

5801 [Memory Clear] (☛ 5.3.2)			
5801 001	All		Executes SP5-801-002 through 019.
5801 002	ENG All		Resets or deletes the engine-related data.
5801 003	SCS		Clears the system settings.
5801 004	IMH		Clears IMH data. DFU
5801 005	MCS		Clears MCS data. DFU
5801 008	PRT		Clears the printer application settings.
5801 010	Web Service		Clears the netfile application management files and thumbnails, and initializes the job login ID.
5801 011	NCS		Initializes the system default and interface settings (IP address also), SmartNetMonitor for Admin, WebStatusMonitor settings, and the TELNET settings.
5801 014	DCS Setting		Resets or deletes the DCS-related data.
5801 015	Clear UCS Setting		Resets or deletes the UCS-related data.
5801 016	MIRS Setting		Resets or deletes the MIRS-related data.
5801 017	CCS		Initializes the CCS (Certification and Charge-control Service) settings.
5801 018	SRM		Initializes the SRM settings
5801 019	LCS Setting		Initializes the LCS settings and logs.

5802 [EngineFreeRun]			
Performs a free run on the printer engine.			
NOTE:			
<ul style="list-style-type: none"> • The machine starts free run in the same condition as the sequence of A4/LT printing from the 1st tray. Therefore, paper should be loaded in the 1st tray, but paper is not fed. • The main switch has to be turned off and on after using the free run mode for a test. 			

5803 [Input Check] (☛ 5.3.3)			
5804 [Output Check] (☛ 5.3.4)			

5808 [Destination]			
	Destination Code Display	*BCU	[0 to 3 / 0 / -] 0: DOM, 1: NA, 2: EURO, 3: ASIA
Displays the destination code.			

5809 [SC OFF] SC Detection ON/OFF			
		*BCU	[0 or 1 / 0 / -] Alphanumeric 0: Enable, 1: Disable
5809 001	ALL		Enable or disables the service call detection. The SC codes (not related to the waste toner vibrator) are all ignored when SP5-809-001 is enabled.

5810 [SC Reset]			
Resets a type A service call condition. Turn the main power switch off and on after resetting the SC code.			

5811	[SN Display] Serial Number Display	*BCU	
	Displays the machine serial number.		

5812	[Tel. No. Setting]	*CTL	
	5812 001	Service	
	Sets the telephone number for a service representative. This number is printed on the Counter List, which can be printed with the user's "Counter" menu. This can be up to 20 characters (both numbers and alphabetic characters can be input).		
	5812 002	FAX TEL No.	
	Sets the fax or telephone number for a service representative. This number is printed on the Counter List, which can be printed with the user's "Counter" menu if the Meter Charge mode is selected with SP5-930-1. This can be up to 13 characters (both numbers and alphabetic characters can be input).		

5816	[Remote Service]		
	Used for NRS only		
5816 001	I/F Setting	*CTL	[0 to 1 / <u>1</u> / 1/step] Alphanumeric 0: OFF 1: Network (The remote service function is on.)
5816 002	CE Call	*CTL	[0 to 1 / <u>0</u> / 1/step] Alphanumeric 0: Start, 1: End
5816 003	Function Flag	*CTL	[0 to 1 / <u>0</u> / 1/step] 0: Off (The remote service function is disabled.) 1: On (The remote service function is enabled.)
5816 006	Device Information	*CTL	[0 to 1 / <u>0</u> / 1/step] 0: Not displayed, 1: Displayed
	Shows or does not show the device information in the User Tools.		
5816 007	SSL Disable	*CTL	[0 to 1 / <u>0</u> / 1/step] 0: Enabled, 1: Disabled
5816 008	RCG Connect Time	*CTL	[1 to 90 / <u>10</u> / 1 second/step]
	Sets the timeout counter for the remote connection.		
5816 009	RCG Write Timeout	*CTL	[0 to 100 / <u>60</u> / 1 second/step]
	Sets the timeout counter for writing processing.		
5816 010	RCG Read Timeout	*CTL	[0 to 100 / <u>60</u> / 1 second/step]
	Sets the timeout counter for reading processing.		
5816 011	Port 80 Enable	*CTL	[0 to 1 / <u>0</u> / 1/step] 0: Disables, 1: Enables
	Enables or disables access to the SOAP method via port 80.		
5816 021	RCG-C Registered	*CTL	Not used
	This SP is not used at this time		
5816 022	RCG-C Regist Det	*CTL	Not used
	This SP is not used at this time		
5816 023	Connect Type		Not used
	This SP is not used at this time		
5816 061	Cert Expire Time		Not used
	This SP is not used at this time		
5816 062	Use Proxy		Not used
	This SP is not used at this time		
5816 067	CERT: Up State		Not used
	This SP is not used at this time		
5816 068	CERT: Error		Not used
	This SP is not used at this time		

5816	[Remote Service]		
	Used for NRS only		
5816 069	CERT: Up ID		Not used
	This SP is not used at this time		
5816 083	Firm Up Status		Not used
	This SP is not used at this time		
5816 084	Non-HDD Firm Up		Not used
	This SP is not used at this time		
5816 085	Firm Up User Che		Not used
	This SP is not used at this time		
5816 086	Firmware Size		Not used
	This SP is not used at this time		
5816 087	CERT: Macro Ver.		Not used
	This SP is not used at this time		
5816 088	CERT: PAC Ver.		Not used
	This SP is not used at this time		
5816 089	CERT: ID2 Code		Not used
	This SP is not used at this time		
5816 090	CERT: Subject		Not used
	This SP is not used at this time		
5816 091	CERT: Serial No.		Not used
	This SP is not used at this time		
5816 092	CERT: Issuer		Not used
	This SP is not used at this time		
5816 093	CERT: Valid Start		Not used
	This SP is not used at this time		
5816 094	CERT: Valid End		Not used
	This SP is not used at this time		
5816 200	Manual Polling		Not used
	This SP is not used at this time		
5816 201	Regist Status		Not used
	This SP is not used at this time		
5816 202	Letter Number		Not used
	This SP is not used at this time		
5816 203	Confirm Execute		Not used
	This SP is not used at this time		
5816 204	Confirm Result		Not used
	This SP is not used at this time		
5816 205	Confirm Place		Not used
	This SP is not used at this time		
5816 206	Register Execute		Not used
	This SP is not used at this time		
5816 207	Register Result		Not used
	This SP is not used at this time		
5816 208	Error Code		Not used
	This SP is not used at this time		
5816 250	CommLog Print		Not used
	This SP is not used at this time		

5821	[Remote Service Address]		
5821 001	CSS-PI Device Code	*CTL	[0 to 4 / 0 / 1/step] DFU
5821 002	RCG IP Address	*CTL	[00000000h to FFFFFFFFh / 00000000h / 1/step]
	Sets the IP address of the RCG (Remote Communication Gate).		

5824	[NVRAMUpload] NVRAM Upload	#	
	Uploads the UP and SP mode data (except for counters and the serial number) from the NVRAM to an SD card.		

5825	[NVRAMDownload] NVRAM Download	#	
	Downloads the UP and SP mode data from an SD card to the NVRAM.		

5828	[Network] Job spool settings/ Interface selection for Ethernet and wireless LAN		
5828 050	1284 Compatible (Centro)	*CTL	[0 or 1 / <u>1</u> / 1 / step] 0: Disabled, 1: Enabled Enables or disables 1284 Compatibility.
5828 052	ECP (Centro)	*CTL	[0 or 1 / <u>1</u> / 1 / step] 0: Disabled, 1: Enabled NOTE: This SP is activated only when SP5-828-50 is set to "1". Enables or disables ECP Compatibility.
5828 65	Job Spool	*CTL	[0 or 1 / <u>0</u> / 1 / step] 0: Disabled, 1: Enabled Enables/disables Job Spooling.
5828 066	HD job Clear	*CTL	[0 to 1 / <u>1</u> / 1/step] Alphanumeric 0: OFF 1: ON (Prints jobs before clearing job data) Treatment of the job when a spooled job exists at power on.
5828 069	Job Spool (Protocol)	*CTL	[0 to 1 / <u>1</u> / 1/step] 0: Off, 1: On Bit switch: • Bit 0: LPR • Bit 1: FPT • Bit 2: IPP • Bit 3: SMB • Bits 4 to 7: Reserved Switches job spooling off or on and enables settings for job spooling protocols.
5828 084	Print Settings List	*CTL	Prints a list of NCS related parameters.
5828 090	TELNET	*CTL	[0 to 1 / <u>1</u> / 1/step] 0: Disabled, 1: Enabled Enables or disables Telnet.
5828 091	Web	*CTL	[0 to 1 / <u>1</u> / 1/step] 0: Disabled, 1: Enabled Enables or disables the Web monitor.

5832	[HDD Init.] HDD Initialization		
	Prepares the hard disk. Use this SP mode only when there is a hard disk error.		

5839	[IEEE1394]	*CTL	
5839 007	Cycle Master		Turns the cycle master function on/off. [0 or 1 / <u>1</u> / 1 /step] 0: OFF 1: ON
5839 008	BCR mode		Selects either 'Standard', 'IRM Color Copy', or ' <u>Always Effective</u> '.
5839 009	IRM 1394a Check		Turns the IRM 1394a check on/off. [0 or 1 / <u>0</u> / -] 0: OFF 1: ON If the IRM is not defined as 1394a standard, its node is used as IRM.
5839 010	Unique ID		Turns on/off the function of the unique ID enumeration. [0 or 1 / <u>1</u> / -] 0: OFF 1: ON
5839 011	Logout		Prevents initiators from logging on or makes initiators log off. [0 or 1 / <u>1</u> / -] 0: OFF (Prevents the initiators, having already logged on, to log on if they try to log on.) 1: ON (Makes initiators, having already logged on, to log off if they try to log on.)
5839 012	Login		Allows/disallows an initiator to exclusively log on. [0 or 1 / <u>0</u> / -] 0: OFF (Disallows) 1: ON (Allows)
5839 013	Login MAX		Specifies the maximum initiators able to log on. [0 to 63 / <u>8</u> / 1 /step]

5840	[IEEE 802.11b]	*CTL	
5840 006	Channel Max		[1 to 11 or 14 / <u>1</u> / 1 /step] Europe/Asia: 1 to 13 USA: 1 to 11 Note: Do not change the setting
	Sets the maximum number of channels available for data transmission via the wireless LAN. The number of channels available varies according to location. The default settings are set for the maximum end of the range for each area. Adjust the upper 4 bits to set the maximum number of channels. DFU		
5840 007	Channel Min		[1 to 11 or 14 / <u>1</u> / 1 /step] Europe/Asia: 1 to 13 USA: 1 to 11 Note: Do not change the setting
	Sets the minimum number of channels available for data transmission via the wireless LAN. The number of channels available varies according to location. The default settings are set for the minimum end of the range for each area. Adjust the lower 4 bits to set the minimum number of channels. DFU		

5840	[IEEE 802.11b]		
5840 011	WEP key number	*CTL	[00~11 / 00 / 1 binary] 00: Key #1 01: Key #2 (Reserved) 10: Key #3 (Reserved) 11: Key #4 (Reserved)
Selects the WEP key.			

5842	[NFA analysis] Net File Analysis Mode Setting DFU		
5842 1	NFA analysis	*CTL	Default: 0000000 – do not change Netfiles: Jobs to be printed from the document server using a PC and the DeskTopBinder software

5844	[USB]		
5844 001	Transfer Rate	*CTL	Adjusts the USB transfer rate. [0 to 1 / 0 / 1/step] Alphanumeric 0: Auto Change, 1: Full speed
5844 002	Vendor ID	*CTL	Displays the vendor ID. DFU
5844 003	Product ID	*CTL	Displays the product ID. DFU
5844 004	Dev Release Num	*CTL	Displays the development release version number. DFU

5845	[Delivery Srv] Delivery Server		
5845 003	Retry Interval	*CTL	[60 to 900 / 300 / 1 second/step]
Specifies the retry interval.			
5845 004	No. of Retries	*CTL	[0 to 99 / 3 / 1/step]
Specifies the maximum number of retries.			

5846	[UCS Setting]		
5846 003	Maximum Entries	*CTL	
Displays the number of maximum entries.			
5846 050	Initialize All Dir	*CTL #	
Initializes all address book data in the UCS except administrator account data.			
5846 060	Search option		[0 to 255 / 15 / Bit switches] Bit 0: No distinction between cap and small letter Bit 1 and 3: Japan use only
Sets the condition of the search option that searches an address in the UCS.			
5846 062	Complexity opt 1		Not used
5846 063	Complexity opt 2		Not used
5846 064	Complexity opt 3		Not used
5846 065	Complexity opt 4		Not used

5848 [Web Service]			
5848 004	ac: ud (Access control: User directory)	*CTL	Switches access control on and off. 0000: No access control 0001: Denies access to DeskTop Binder.
5848 009	ac: jc (Access control: Job control)	*CTL	
5848 011	ac: dm (Access control: Device management)	*CTL	
5848 201	Regular Trans		Not used
5848 210	LogType: Job 1		Not used
5848 211	LogType: Job 2		Not used
5848 212	LogType: Access		Not used
5848 213	Primary Srv		Not used
5848 214	Secondary Srv		Not used
5848 215	Start Time		Not used
5848 216	Interval Time		[0 to 1000 / 1 / 1 hour/step]
	Adjusts the transmission interval time for Web Service. This SP is enabled only when SP5848-217 is set to "2".		
5848 217	Timing		[0 to 2 / 0 / 1 /step] 0: Transmission off 1: One by one transmission 2: Interval transmission
	Sets the transmission timing for Web Service.		

5851 [Bluetooth]			
5851 001	Mode	*CTL	[0 to 1 / 0 / 1/step] Alphanumeric 0: Public, 1: Private
	Selects the Bluetooth mode.		

5856 [Remote Update] Remote ROM Update			
5856 002	Local Port	*CTL	[0 to 1 / 0 / 1/step] 0: Disable, 1: Enable
	Allows the technician to upgrade the firmware using a parallel cable when updating the remote ROM.		

5857 [Save Debug Log]			
5857 001	On/Off	*CTL	[0 to 1 / 0 / 1/step] 0: OFF, 1: ON
	Enables or disables the debug log saving function.		
5857 002	Target	*CTL	[2 to 3 / 2 / 1/step] 2: HDD, 3: SD
	Sets the storage location for the debug log.		
5857 005	Save to HDD	*CTL	
	Sets the key number of the debug log.		
5857 006	Save to SD	*CTL	
	Sets the key number of the debug log.		
5857 009	HDD to SD (4MB)	*CTL	
	Copies the most recent 4 MB of the debug log from the hard disk to the SD card.		
5857 010	HDD to SD (Any)	*CTL	
	Sets the key number of the debug log copied from the hard disk to the SD card.		

Service Tables

5857		[Save Debug Log]	
5857 011	Erase HDD Log	*CTL	
	Deletes the debug log from the hard disk.		
5857 012	Erase SD Log	*CTL	
	Deletes the debug log from the SD card.		
5857 013	Free Space on SD	*CTL	
	Shows the free space on the SD card.		
5857 014	SD to SD (4MB)	*CTL	
	Copies the most recent 4 MB of the debug log from an SD card to a different SD card.		
5857 015	SD to SD (Any)	*CTL	
	Sets the key number of the debug log copied from an SD card to a different SD card.		
5857 016	Make HDD Log File	*CTL	Makes a log file on the HDD to save debug logs. To save debug logs, the controller makes a log file first, then writes data in the file. This procedure can use much time. The user can switch off the main power switch before the log is written in the file. To prevent this possible problem, you can prepare a log file in advance. If you do this, the controller uses less time to save logs because the log file is prepared.
5857 017	Make SD Log File	*CTL	

5858		[Debug Save When]	
5858 001	Engine SC Error	*CTL	[0 to 1 / 0 / 1/step] Alphanumeric 0: OFF, 1: ON
	Collects debug logs when an engine-related SC code occurs.		
5858 002	System SC Error	*CTL	[0 to 1 / 0 / 1/step] Alphanumeric 0: OFF, 1: ON
	Collects debug logs when a controller-related SC code occurs.		
5858 003	Any SC Error	*CTL	[00000 to 65535 / 0 / 1/step]
	Sets the SC code whose logs are collected.		
5858 004	Jam	*CTL	[0 to 1 / 0 / 1/step] Alphanumeric 0: OFF, 1: ON
	Collects debug logs when a paper jam occurs.		

5859		[Log Save Key No.]	
5859 001	Key 1	*CTL	[0000000 to 9999999 / 0 / 1/step]
5859 002	Key 2		
5859 003	Key 3		
5859 004	Key 4		
5859 005	Key 5		
5859 006	Key 6		
5859 007	Key 7		
5859 008	Key 8		
5859 009	Key 9		
5859 010	Key 10		

Sets the key number of a specific event (☛ NOTE) whose logs are saved in the specified storage (☛ NOTE). When multiple key numbers are assigned, the logs are collected in this order: Key 1, Key 2, ..., Key 9, Key 10.
NOTE: The event is set with SP5-858. The storage is set with SP5-857-2.

5860		[SMTP/POP3/IMAP]	
5860 002	SMTP Srv Port No.	*CTL	[1 to 65535 / 25 / 1/step]
	Specifies the number of the SMTP server ports.		

5860		[SMTP/POP3/IMAP]	
5860 003	SMTP Auth	*CTL	[0 to 1 / 0 / 1/step] 0: Disable, 1: Enable
	Enables or disables the SMTP authentication for mail transfers.		
5860 006	SMTP Auth Encryp	*CTL	[0 to 2 / 0 / 1/step] 0: Automatic, 1: Not encrypt, 2: Encrypt
	Encrypts or does not encrypt passwords for SMTP authentications.		
5860 007	POP before SMTP	*CTL	[0 to 1 / 0 / 1/step] 0: Disable, 1: Enable
	Enables or disables the authentication that is executed on the POP server before the communication is established with the SMTP server to transfer mails.		
5860 008	POP to SMTP Wait	*CTL	[0 to 10000 / 300 / 1 ms/step]
	Specifies the waiting time to access the SMTP server after the authentication on the POP server.		
5860 009	Rcv Protocol	*CTL	[1 to 3 / 1 / 1 /step] 1: POP3, 2: IMAP4, 3: SMTP
	Sets the receiving protocol for receiving an e-mail.		
5860 013	POP Auth. Encrypt	*CTL	[0 to 2 / 0 / 1/step] 0: Automatic, 1: Not encrypt, 2: Encrypt
	Encrypts or does not encrypt passwords for POP3/IMAP4 authentications.		
5860 014	POP Server Port No.	*CTL	[1 to 65535 / 110 / 1/step]
	Specifies the port number of the POP server.		
5860 015	IMAP Srv Port No	*CTL	[1 to 65535 / 143 / 1/step]
	Specifies the port number of the IMAP4 server.		
5860 017	Receive Interval	*CTL	[2 to 1440 / 3 / 1 min/step]
	Specifies the interval for receiving an e-mail.		
5860 019	Mail Keep Sett.	*CTL	[0 to 2 / 0 / 1 /step] 0: No keep, 1: All, 2: Error mail
	Sets the mail type kept in the mail server after receiving an e-mail. When you set the "1", all e-mails are kept in the mail server after receiving an e-mail. When you set the "2", only error mails are kept in the mail server after receiving an e-mail. When you set the "0", no e-mail is kept in the mail server after receiving an e-mail.		
5860 020	Part. Mail Rcv Tm	*CTL	[1 to 168 / 72 / -]
	Sets the amount of time to wait before saving a mail that breaks up during reception. The received mail is discarded if the remaining portion of the mail is not received during this prescribed time.		
5860 021	MDN Res RFC2298	*CTL	[0 to 1 / 1 / -] 0: No, 1: Yes
	Determines whether RFC2298 compliance is switched on for MDN reply mail.		
5860 022	SMTP From Replace	*CTL	[0 to 1 / 0 / 1/step]
	Determines whether the FROM item of the mail header is switched to the validated account after the SMTP server is validated. 0: No. "From" item not switched, 1: Yes. "From" item switched.		
5860 025	SMTP Auth Direct		[0 or 1 / 0 / -] <i>Bit switch:</i> • Bit 0: LOGIN • Bit 1: PLAIN • Bit 2: CRAM MD5 • Bit 3: DIGEST MD5 • Bit 4 to 7: Not used
	Selects the authentication method for SMPT. NOTE: This SP is activated only when SMTP authorization is enabled with UP mode.		

5866	[Mail: Date Field]	*CTL	[0 to 1 / 0 / 1/step] 0: Not attached, 1: Attached
	Attaches or does not attach the data field to the header of alert e-mail.		

5869	[RAM Disk Setting]		
	5869 001	Mail Function	*CTL# [0 to 1 / 0 / 1/step] 0: ON, 1: OFF
Enables or disables the e-mail transfer function. This SP sets the RAM disk size for the e-mail transfer function.			

5870	[Common Key Info Writing]		
	5870 001	Writing	*CTL Writes the authentication data (used for NRS) in the memory.
5870 003	Initialize	*CTL	Initializes the authentication data (used for NRS) in the memory.

5873	[SD Card Appli Move]		
	5873 001	Move Exec	(☛ 5.5)
5873 002	Undo Exec		

5876	[Security Clear]		
	5876 010	Clear WS	Clears the Net File area security data. DFU

5907	[Plug/Play] Plug & Play Name Selection																																																						
	5907 001	Plug/Play	*BCU Specifies the manufacturer and model name. [0 to 11 / 0 / 1/step] FA																																																				
<table border="1"> <thead> <tr> <th></th> <th>MF</th> <th>Model Name</th> <th>NetBeui</th> </tr> </thead> <tbody> <tr> <td>0</td> <td>Ricoh</td> <td>Aficio CL7200</td> <td>Aficio CL7200</td> </tr> <tr> <td>1</td> <td>Ricoh</td> <td>Aficio CL7300</td> <td>Aficio CL7300</td> </tr> <tr> <td>2</td> <td>Savin</td> <td>CLP128</td> <td>CLP128</td> </tr> <tr> <td>3</td> <td>Savin</td> <td>CLP135</td> <td>CLP135</td> </tr> <tr> <td>4</td> <td>Gestetner</td> <td>C7528n</td> <td>C7528n</td> </tr> <tr> <td>5</td> <td>Gestetner</td> <td>C7535n</td> <td>C7535n</td> </tr> <tr> <td>6</td> <td>NRG</td> <td>C7528n</td> <td>C7528n</td> </tr> <tr> <td>7</td> <td>NRG</td> <td>C7535hdn</td> <td>C7535hdn</td> </tr> <tr> <td>8</td> <td>Infotec</td> <td>IPC 2832</td> <td>IPC 2832</td> </tr> <tr> <td>9</td> <td>Infotec</td> <td>IPC 3535e</td> <td>IPC 3535e</td> </tr> <tr> <td>10</td> <td>Lanier</td> <td>LP332c</td> <td>LP332c</td> </tr> <tr> <td>11</td> <td>Lanier</td> <td>LP335c</td> <td>LP335c</td> </tr> </tbody> </table>					MF	Model Name	NetBeui	0	Ricoh	Aficio CL7200	Aficio CL7200	1	Ricoh	Aficio CL7300	Aficio CL7300	2	Savin	CLP128	CLP128	3	Savin	CLP135	CLP135	4	Gestetner	C7528n	C7528n	5	Gestetner	C7535n	C7535n	6	NRG	C7528n	C7528n	7	NRG	C7535hdn	C7535hdn	8	Infotec	IPC 2832	IPC 2832	9	Infotec	IPC 3535e	IPC 3535e	10	Lanier	LP332c	LP332c	11	Lanier	LP335c	LP335c
	MF	Model Name	NetBeui																																																				
0	Ricoh	Aficio CL7200	Aficio CL7200																																																				
1	Ricoh	Aficio CL7300	Aficio CL7300																																																				
2	Savin	CLP128	CLP128																																																				
3	Savin	CLP135	CLP135																																																				
4	Gestetner	C7528n	C7528n																																																				
5	Gestetner	C7535n	C7535n																																																				
6	NRG	C7528n	C7528n																																																				
7	NRG	C7535hdn	C7535hdn																																																				
8	Infotec	IPC 2832	IPC 2832																																																				
9	Infotec	IPC 3535e	IPC 3535e																																																				
10	Lanier	LP332c	LP332c																																																				
11	Lanier	LP335c	LP335c																																																				

5930	[Meter Charge] Meter Charge Mode																																																									
5930 001	ON/OFF	*BCU #	[0 or 1 / 0 / -] Alphanumeric 0: OFF, 1: ON																																																							
	Enables or disables the Meter Charge mode. When enabling the Meter Charge mode, the "Counter" menu is added to the user menu.																																																									
5930 003	Menu	*BCU #	[0 or 1 / 1 / -] Alphanumeric 0: Click 2, 1: Click 1																																																							
	<p>Selects the method for displaying the alert when the life of the parts in a maintenance kit has almost ended. The following table lists the machine condition when the near end or end condition of each maintenance unit is detected. In this table, a dash (-) means "normal operation."</p> <table border="1"> <thead> <tr> <th rowspan="2"></th> <th colspan="3">Setting: 1 (Click 1)</th> <th colspan="3">Setting: 0 (Click 2)</th> </tr> <tr> <th>Near</th> <th>End</th> <th>Printing</th> <th>Near</th> <th>End</th> <th>Printing</th> </tr> </thead> <tbody> <tr> <td>A</td> <td>Alert</td> <td>Alert</td> <td>-</td> <td>-</td> <td>-</td> <td>-</td> </tr> <tr> <td>B</td> <td>Alert</td> <td>Alert</td> <td>-</td> <td>-</td> <td>-</td> <td>-</td> </tr> <tr> <td>C</td> <td>Alert</td> <td>Alert</td> <td>-</td> <td>-</td> <td>-</td> <td>-</td> </tr> <tr> <td>D</td> <td>Alert</td> <td>Alert</td> <td>-</td> <td>-</td> <td>-</td> <td>-</td> </tr> <tr> <td>E</td> <td>Alert</td> <td>Alert</td> <td>Stop</td> <td>Alert</td> <td>Alert</td> <td>Stop</td> </tr> <tr> <td>F</td> <td>Alert</td> <td>Alert</td> <td>-</td> <td>-</td> <td>-</td> <td>-</td> </tr> </tbody> </table> <p>A: Color PCU B: Color Development Unit C: Fusing Unit D: Black Development Unit E: Waste Toner Bottle F: Black PCU</p> <p>NOTE: SP5-930-004 allows the alert for the paper feed roller to show.</p>				Setting: 1 (Click 1)			Setting: 0 (Click 2)			Near	End	Printing	Near	End	Printing	A	Alert	Alert	-	-	-	-	B	Alert	Alert	-	-	-	-	C	Alert	Alert	-	-	-	-	D	Alert	Alert	-	-	-	-	E	Alert	Alert	Stop	Alert	Alert	Stop	F	Alert	Alert	-	-	-	-
	Setting: 1 (Click 1)				Setting: 0 (Click 2)																																																					
	Near	End	Printing	Near	End	Printing																																																				
A	Alert	Alert	-	-	-	-																																																				
B	Alert	Alert	-	-	-	-																																																				
C	Alert	Alert	-	-	-	-																																																				
D	Alert	Alert	-	-	-	-																																																				
E	Alert	Alert	Stop	Alert	Alert	Stop																																																				
F	Alert	Alert	-	-	-	-																																																				
5930 004	Paper Feed	*BCU #	[0 or 1 / 0 / -] Alphanumeric 0: No Alert, 1: Alert																																																							
	Determines whether to display the alert when the life of the paper feed unit is nearly ended.																																																									
5930 005	Paper Trans.	*BCU #	[0 or 1 / 0 / -] Alphanumeric 0: No Alert, 1: Alert																																																							
	Determines whether to display the alert when the life of the transfer unit or transfer belt-cleaning unit is nearly ended.																																																									
5930 006	Factory Use		Not used in this machine.																																																							

Service Tables

5961	[Finisher Stack] Finisher Maximum Stack	*BCU #	[0 or 1 / 1 / -] Alphanumeric 0: No, 1: Yes
	<p>Enables or disables maximum stack mode for the lower shift tray only in staple mode. If this is enabled, the upper tray can be used for stacking 500 sheets but it stays at the upper exit (will not be used for stapling mode), and the lower tray is used for stacking up to 2,000 sheets. If this is disabled, the upper tray can be used for stacking 500 sheets and the lower tray for 1,500 sheets.</p> <p>NOTE: The main switch must be turned off and on to effect the setting change.</p>		

5989	[Loop Back Test]		
5989 001	Duplex		Executes a communication test with peripherals by using a special tool (connector) which is unique for each peripheral. The machine checks if the communication with the peripherals is OK or NG; then displays the result. DFU
5989 003	Finisher		
5989 004	PSU		

5990	[SP print mode]		
5990 001	All (Data List)		Does SP5-990-002, 004, 005, 006, and 007.
5990 002	SP (Mode Data List)		Prints an SMC report on all SP modes.
5990 004	Logging Data		Prints an SMC report on the SPs that save logs.
5990 005	Diagnostic Report		Prints the Self-Diagnosis Report.
5990 006	Non-Default		Prints an SMC report on the SPs that have settings which are different from the defaults.
5990 007	NIB Summary		Prints the network configuration report.

5991	[Jam OFF/ON] Jam ON/OFF		[0 or 1 / 0 / -] Alphanumeric 0: Enable, 1: Disable
Enables or disables jam detection.			

5993	[Line Adj.] Line Adjustment		
Line Positioning Adjustment ([Color]) M: Main-scan, S: Sub-scan, Reg.: Registration, Mag.: Magnification For example: M Reg = Main scan registration			
5993 001	Mode Selection	*BCU	[0 to 2 / 1 / 1/step] Alphanumeric 0: Never done 1: Process Control Done at a) all process control self checks except after toner end recovery and developer initialisation. b) new PCU detected. c) the temperature has changed by 5°C since the last adjustment. 2: Except ProCon As for setting "1", except it is not done during self-checks. However, it is done at the initial process control self check. The size of the 5°C difference can be changed with SP5-993-3
Specifies when the automatic line position adjustment is done.			
5993 002	Execute		Use to make a line position adjustment.
5993 003	Temperature	*BCU	[3 to 15 / 5 / 1°C]
Specifies the temperature for starting the line positioning adjustment. The line position adjustment automatically starts when the temperature differs by the amount specified in this SP mode from the temperature when the last adjustment was done. There are two thermistors on the laser optics-housing unit. The thermistor close to the fusing unit monitors the temperature for this adjustment.			

5993	[Line Adj.] Line Adjustment		
	Line Positioning Adjustment ([Color]) M: Main-scan, S: Sub-scan, Reg.: Registration, Mag.: Magnification For example: M Reg = Main scan registration		
5993 022	Interrupt	*BCU	[10 to 250 / <u>100</u> / 10 sheets/step]
	Specifies the number of sheets to be printed before a line position adjustment is done during a print job. SP 5-993-4 must be enabled. When the temperature difference meets the conditions specified in SP5-993-3, the machine starts counting the number of prints in the job. The machine interrupts the print job and does the line position adjustment if the number of prints exceeds the number specified in this SP mode. If the counted number of prints does not exceed the number specified, the machine resets the counter, then continues to monitor the temperature and does the line position adjustment next time.		
5993 025	Drum Gear Phase	*BCU	[0 to 345 / <u>0</u> / 15 degrees/step] DFU
	Adjusts the phases of the black drum gear and the color drum gear.		
5993 026	Initialization	*BCU	[0 to 1 / <u>0</u> / 0/step] Alphanumeric 0: Disable, 1: Enable
	Enables or disables the line position adjustment during initialization.		
5993 027	Toner Refresh	*BCU	[0 to 1 / <u>3</u> / 1/step] Alphanumeric 0: Disable, 1: Line adj., 2: PPS, 3: Line adj. & PPS
	Selects the toner refreshing operation timing. Repetitive line position adjustments can cause abnormal outputs such as white spots. To prevent this, toner is consumed and supplied after line position adjustment.		
5993 031	PPS: M		Checks the transfer PPS in the 162-mm/s mode (G131) or 125-mm/s mode (G130). Use this SP only as explained in section 4.5.2.
5993 032	PPS Set: M	*BCU	G130: [6043 to 6166 / 6105 / 1 /step] G131: [7832 to 7991 / 7912 / 1 /step]
	Adjusts the transfer PPS in the 125-mm/s / 162-mm/s mode. Use this SP only as explained in section 4.5.2.		
5993 033	PPS: L		Checks the transfer PPS in the 81-mm/s mode. Use this SP only as explained in section 4.5.2.
5993 034	PPS Set: L	*BCU	[7832 to 7991 / 7912 / 1 /step]
	Adjusts the transfer PPS in the 81-mm/s mode. Use this SP only as explained in section 4.5.2.		

5993	[Line Adj.] Line Adjustment																																																																																																																		
	Line Positioning Adjustment ([Color]) M: Main-scan, S: Sub-scan, Reg.: Registration, Mag.: Magnification For example: M Reg = Main scan registration																																																																																																																		
5993 035	Adj level	*BCU	[0 to 5 / <u>1</u> / 1 /step] Alphanumeric 0: HIGH <u>1</u> : MID 2: LOW 3: BW-HI 4: BW-MID 5: BW-LOW																																																																																																																
This SP specifies the level of color adjustment. This SP sets the following SPs as listed.																																																																																																																			
<table border="1"> <thead> <tr> <th></th> <th>HI</th> <th>MID</th> <th>LOW</th> <th>BW-HI</th> <th>BW-MID</th> <th>BW-LOW</th> </tr> </thead> <tbody> <tr> <td>SP2-919-003</td> <td>0</td> <td>0</td> <td>0</td> <td>0</td> <td>0</td> <td>0</td> </tr> <tr> <td>SP3-125-003</td> <td>1</td> <td>0</td> <td>0</td> <td>1</td> <td>0</td> <td>0</td> </tr> <tr> <td>SP3-906-001</td> <td>200</td> <td>200</td> <td>999</td> <td>200</td> <td>200</td> <td>999</td> </tr> <tr> <td>SP3-906-002</td> <td>200</td> <td>0</td> <td>0</td> <td>200</td> <td>0</td> <td>0</td> </tr> <tr> <td>SP3-906-003</td> <td>0</td> <td>0</td> <td>0</td> <td>0</td> <td>0</td> <td>0</td> </tr> <tr> <td>SP3-906-004</td> <td>480</td> <td>480</td> <td>480</td> <td>480</td> <td>480</td> <td>480</td> </tr> <tr> <td>SP3-906-005</td> <td>1.00</td> <td>1.00</td> <td>1.00</td> <td>0.20</td> <td>0.20</td> <td>0.20</td> </tr> <tr> <td>SP5-993-001</td> <td>1</td> <td>1</td> <td>1</td> <td>1</td> <td>1</td> <td>1</td> </tr> <tr> <td>SP5-993-003</td> <td>3</td> <td>5</td> <td>7</td> <td>3</td> <td>5</td> <td>7</td> </tr> <tr> <td>SP5-993-004</td> <td>1</td> <td>1</td> <td>1</td> <td>1</td> <td>1</td> <td>1</td> </tr> <tr> <td>SP5-993-005</td> <td>0</td> <td>0</td> <td>0</td> <td>0</td> <td>0</td> <td>0</td> </tr> <tr> <td>SP5-993-006</td> <td>1</td> <td>1</td> <td>0</td> <td>1</td> <td>1</td> <td>0</td> </tr> <tr> <td>SP5-993-022</td> <td>100</td> <td>100</td> <td>250</td> <td>100</td> <td>100</td> <td>250</td> </tr> <tr> <td>SP5-993-026</td> <td>1</td> <td>0</td> <td>0</td> <td>1</td> <td>0</td> <td>0</td> </tr> <tr> <td>SP5-993-055</td> <td>0</td> <td>0</td> <td>0</td> <td>100</td> <td>200</td> <td>999</td> </tr> </tbody> </table>					HI	MID	LOW	BW-HI	BW-MID	BW-LOW	SP2-919-003	0	0	0	0	0	0	SP3-125-003	1	0	0	1	0	0	SP3-906-001	200	200	999	200	200	999	SP3-906-002	200	0	0	200	0	0	SP3-906-003	0	0	0	0	0	0	SP3-906-004	480	480	480	480	480	480	SP3-906-005	1.00	1.00	1.00	0.20	0.20	0.20	SP5-993-001	1	1	1	1	1	1	SP5-993-003	3	5	7	3	5	7	SP5-993-004	1	1	1	1	1	1	SP5-993-005	0	0	0	0	0	0	SP5-993-006	1	1	0	1	1	0	SP5-993-022	100	100	250	100	100	250	SP5-993-026	1	0	0	1	0	0	SP5-993-055	0	0	0	100	200	999
	HI	MID	LOW	BW-HI	BW-MID	BW-LOW																																																																																																													
SP2-919-003	0	0	0	0	0	0																																																																																																													
SP3-125-003	1	0	0	1	0	0																																																																																																													
SP3-906-001	200	200	999	200	200	999																																																																																																													
SP3-906-002	200	0	0	200	0	0																																																																																																													
SP3-906-003	0	0	0	0	0	0																																																																																																													
SP3-906-004	480	480	480	480	480	480																																																																																																													
SP3-906-005	1.00	1.00	1.00	0.20	0.20	0.20																																																																																																													
SP5-993-001	1	1	1	1	1	1																																																																																																													
SP5-993-003	3	5	7	3	5	7																																																																																																													
SP5-993-004	1	1	1	1	1	1																																																																																																													
SP5-993-005	0	0	0	0	0	0																																																																																																													
SP5-993-006	1	1	0	1	1	0																																																																																																													
SP5-993-022	100	100	250	100	100	250																																																																																																													
SP5-993-026	1	0	0	1	0	0																																																																																																													
SP5-993-055	0	0	0	100	200	999																																																																																																													
The adjustment numbers from 3 to 5 are for users who mainly use this machine for black and white printing.																																																																																																																			
36 to 38	Finely adjusts the main-scan registration. This SP can adjust the main scan registration more precisely than the SP5993-10 to -12. Used for fine main scan offset.																																																																																																																		
5993 036	S: Off Set: [Y]	*BCU	[-15 to 15 / <u>0</u> / 1/16dot /step] FA																																																																																																																
5993 037	S: Off Set: [M]	*BCU																																																																																																																	
5993 038	S: Off Set: [C]	*BCU																																																																																																																	
5993 039	Execute	*BCU																																																																																																																	
Use to make a rough line position adjustment. If color registration errors are more than 1.4 mm, use this SP. After doing this SP, do SP5-993-2 (Line position adjustment).																																																																																																																			
5993 040	Color_Adj_level (for warming up)	*BCU	[0 or 1 / <u>1</u> / -] Alphanumeric																																																																																																																
Sets the line position adjustment type when the fusing temperature is 60°C or less immediately after the main power is turned on. 0: High (Skew adjustment once, main and sub scan magnification and registration adjustment twice) 1: Mid (Skew adjustment once, main and sub scan magnification and registration adjustment once)																																																																																																																			
5993 041	Color_Adj_level	*BCU	[0 or 1 / <u>1</u> / -] Alphanumeric																																																																																																																
Sets the line position adjustment type when the fusing temperature is more than 60°C immediately after the main power is turned on. 0: Mid (Main and sub scan magnification adjustment twice) 1: Low (Main and sub scan magnification adjustment once)																																																																																																																			

Service Tables

5993	[Line Adj.] Line Adjustment		
	Line Positioning Adjustment ([Color]) M: Main-scan, S: Sub-scan, Reg.: Registration, Mag.: Magnification For example: M Reg = Main scan registration		
42 to 044	These SPs adjust the main scan registration when it is in 1200 dpi printing mode. The polygon motor speed is different between the 1200 dpi printing mode and other dpi printing modes. Because of this, the registration position of 1200 dpi printing mode is slightly different from other printing modes. Example: If magenta is always shifted one dot to the left, reduce 5-993-43 by 1.		
5993 042	M: Offset: 1200 [Y]	*BCU	[-128 to 127 / 0 / 1 /step] FA
5993 043	M: Offset: 1200 [M]	*BCU	
5993 044	M: Offset: 1200 [C]	*BCU	
45 to 47	These SPs adjust the main scan registration by 1/16 dot when it is in 1200 dpi printing mode.		
5993 045	M Offset 2 1200 [Y]	*BCU	[-15 to 15 / 0 / 1/16dot /step] FA
5993 046	M Offset 2 1200 [M]	*BCU	
5993 047	M Offset 2 1200 [C]	*BCU	
5993 048	Pulse: Y	*BCU	Displays the correction pulse value of the main-scan magnification for yellow, cyan and magenta adjusted by the line position adjustment.
5993 049	Pulse: M	*BCU	
5993 050	Pulse: C	*BCU	
51 to 53	Specifies the correction pulse value at the center of the image. This SP is used when color registration errors occur at the center of the main scan but not at the sides, after the line position adjustment is done. The values of these SPs are added to the correction values that are adjusted by the center ID sensor when doing the line position adjustment. <ul style="list-style-type: none"> • A "-" value shifts the image to the front side of the machine (left side of the image). • A "+" value shifts the image to the rear side of the machine (right side of the image). 		
5993 051	D Mag Offset [Y]	*BCU	[-1023 to 1023 / 0 / 1 pulse /step] FA
5993 052	D Mag Offset [M]	*BCU	
5993 053	D Mag Offset [C]	*BCU	
5993 054	D Mag Adj	*BCU	[0 or 1 / 1 / -] DFU 0: Disable, 1: Enable
	Enables or disables the main-scan magnification adjustment with the center ID sensor. When this SP is at "0", main-scan correction is done only with the rear and front ID sensor during the line position adjustment.		
5993 055	FC Prejob Music	*BCU	[0 to 999 / 0 / 1 sheet /step]
	Specifies the threshold for the line position adjustment when changing from black and white printing and copying mode to color printing mode. When color printing starts after the counter has got to the value set by this SP, the line position adjustment is done before the color printing starts. If the line position adjustment is done because of other conditions, the counter of this SP is cleared.		

5994	[Unit Set] Maintenance Unit Detection ON/OFF		
5994 001	Dev/PCU	*BCU#	[0 or 1 / 0 / -] Alphanumeric 0: Enable, 1: Disable
	Enables or disables PCU and development unit detection. NOTE: If this mode is disabled, new unit detection also does not function. Use this mode as a temporary measure, only when the micro-switches are defective.		
5994 002	Oil Unit	*BCU#	[0 or 1 / 0 / -] Alphanumeric Not Used 0: Enable, 1: Disable
	This is for the oil supply unit only, and not the fusing unit NOTE: Use this mode as a temporary measure, only when the unit detection mechanism is defective.		

5995	[ColorGapAdj2] Color Gap Adjustment 2		
	Transfer belt speed affects image processing. The transfer belt speed needs to be adjusted to uniform speed to ensure good quality image production. This machine has the following two methods to adjust the transfer belt speed: 1. Transfer belt feedback: Fb 2. Dancing control Dnc		
5995 020	Trans Drv FB	*BCU	Enables or disables the transfer belt feedback feature and dancing control. [0 to 2 / 0 / 1 /step] Alphanumeric 0: FbOn, DncOn 1: FbOn, DncOff 2: FbOff, DncOff
	[Trans Drv Danc] Dancing control corrects the belt speed for changes that are caused by deflection of the belt regularity.		
5995 023	Ampli Param	*BCU	DFU
5995 024	Phase Param	*BCU	DFU
5995 025	Error Counter	*BCU	Clears the dancing control error counter.
5995 027	Target		Do this SP to detect the HP mark and measure the belt regularity as a standard value.
5995 028	Drv Rev Set	*BCU	DFU

Service Tables

5997	[Test Pattern]		
5997 001	IntTray		Selects the tray for making a test print. [0 to 4 / 1 / 1/step] 0: By-pass Table 1: Tray 1 2: Tray 2 3: Tray 3 4: Tray 4 NOTE: The machine makes a test pattern on the paper size loaded in the selected paper tray.

5997		[Test Pattern]	
5997 002	Pattern		<p>Selects a test pattern. [0 to 23 / <u>0</u> / 1/step] 0: None 1: 1-dot sub-scan 2: 2-dot sub-scan 3: 1-dot main-scan 4: 2-dot main-scan 5: 1-dot grid (F) 7: 1-dot grid (R) 9: 1-dot slant 11: 1-dot pattern 12: 2-dot pattern 13: 4-dot pattern 15: trimming 16: Cross Stitch S 17: Cross Stitch M 18: Belt Horizontal 19: Belt Vertical 20: Checkereflag 21: Grey scale Ver 22: Grey scale Hor 23: Solid</p>
5997 003	Color		<p>Selects the color for making a test pattern. [0 to 6 / <u>6</u> / 1/step] Alphanumeric 0: Red 1: Green 2: Blue 3: Yellow 4: Magenta 5: Cyan 6: Black</p>
5997 004	Mode		<p>Selects the color mode for making a test print. [0 or 1 / <u>0</u> / 1/step] Alphanumeric 0: Full Color 1: Single Color</p>
5997 005	Resolution		<p>Selects the resolution for making a test print. [0 to 2 / <u>1</u> / 1/step] Alphanumeric 0: 600x600 1: 1200x600 2: 1200x1200</p>
5997 006	MLT Paper Size		<p>Selects the paper size for making a test pattern from the by-pass table. [0 to 3 / <u>0</u> / 1/step] Alphanumeric 0: A4 LEF 1: LT LEF 2: A3 3: DLT</p>
5997 007	Print Exe		<p>Prints the test pattern with the settings specified with SP5-997-001 to 006. NOTE: When exiting the SP mode, the test print mode is automatically canceled.</p>

5998		[Memory Clear] (☛ 5.3.2)	
5998 001	ENG Setting		Clears the engine settings except for counters.
5998 002	ENG Counter		Clears all counters.

SP6-XXX (Peripherals)

6110	[Punch]		
	Adjusts the punching position. Punch 1 US: 2 punch holes Europe: 2 punch holes North Europe: 4 punch holes Punch 2 US: 3 punch holes Europe: 4 punch holes Increment: Holes move toward the paper center. Decrement: Holes move toward the paper edge.		
6110 001	MF Fin 1	*BCU	[-7.5 to 7.5 / 0 / 0.5 mm/step]
6110 002	MF Fin 2	*BCU	
6110 003	Booklet Fin		[-2.5 to 7.5 / 0 / 0.5 mm/step]

6111	[Staple] Staple Position		
	Adjusts the stapling position. Increment: Staple position moves toward the edge of paper. Decrement: Staple position moves toward the center of paper. NOTE: Although the adjustable range is ± 3.5 mm, the stapling position can be changed only by 1.0 mm when stapling one position at the front or rear side even when the input value is more than 1.0.		
6111 001	MF Fin	*BCU	[-3.5 to 3.5 / 0 / 0.5 mm/step]
6111 002	A3	*BCU	[-3.75 to 3.75 / 0 / 0.25 mm/step]
6111 003	B4	*BCU	
6111 004	A4	*BCU	
6111 005	DLT	*BCU	
6111 006	LG	*BCU	
6111 007	LT	*BCU	

6112	[Fold] Fold Position	*BCU	[-3.75 to 3.75 / 0 / 0.25 mm/step]
6111 001	A3		Adjusts the folding positions of the optional booklet finisher.
6111 002	B4		
6112 003	A4		
6112 004	DLT		
6112 005	LG		
6112 006	LT		

SP7-XXX (Data Log)

7001	Working Time	*BCU	Display: 00000000~99999999 min
	The number of prints and drive time for drum revolutions can be obtained by counting the main motor revolution time. If the amount of time required for the drum to revolve to print 1 copy increases, this data combined with the number of copies can be used to analyze problems and could be useful for future product development.		

7401	[SC Counter]	*CTL	[0 to 9999 / 0 / 1/step]
	Displays the number of SC codes detected.		

7502	[Total Jam]	*CTL	[0 to 9999 / 0 / 1 sheet/step]
	Displays the total number of jams detected.		

7504	[Jam Location]		
	ON: On check, OFF: Off Check Displays the number of jams according to the location where jams were detected.		
7504 001	At Power On	*CTL	
7504 003	Tray 1: ON	*CTL	
7504 004	Tray 2: ON	*CTL	
7504 005	Tray 3/LCT: ON	*CTL	
7504 006	Tray 4: ON	*CTL	
7504 008	Registration: ON	*CTL	
7504 009	External Tray: ON	*CTL	
7504 010	Internal Tray: ON	*CTL	
7504 011	Duplex: ON	*CTL	
7504 012	Duplex Exit 1: ON	*CTL	
7504 013	Duplex Exit 2: ON	*CTL	
7504 014	Duplex Exit 3: ON	*CTL	
7504 015	Duplex Feed: ON	*CTL	
7504 020	Mail Box Upper: ON	*CTL	
7504 021	Mail Box Lower: ON	*CTL	
7504 051	Tray 1: OFF	*CTL	
7504 052	Tray 2: OFF	*CTL	
7504 053	Tray 3/LCT: OFF	*CTL	
7504 054	Tray 4: OFF	*CTL	
7504 061	Registration: OFF	*CTL	
7504 063	External Tray: OFF	*CTL	
7504 064	Internal Tray: OFF	*CTL	
7504 065	Duplex: OFF	*CTL	
7504 066	Duplex Exit 1: OFF	*CTL	
7504 067	Duplex Exit 2: OFF	*CTL	
7504 068	Duplex Exit 3: OFF	*CTL	
7504 069	Duplex Feed: OFF	*CTL	
7504 090	Mail Box Upper: OFF	*CTL	
7504 091	Mail Box Lower: OFF	*CTL	
7504 100	Finisher Entrance	*CTL	
7504 101	Finisher Shift Tray 1	*CTL	
7504 102	Finisher Shift Tray 2	*CTL	
7504 103	Finisher Staple	*CTL	
7504 104	Finisher Exit	*CTL	
7504 105	Finisher Drive	*CTL	
7504 106	Finisher Tray Up/Down	*CTL	

7504	[Jam Location]		
	ON: On check, OFF: Off Check		
	Displays the number of jams according to the location where jams were detected.		
7504 107	Finisher Jogger	*CTL	
7504 108	Finisher Staple	*CTL	
7504 109	Finisher Exit	*CTL	
7504 110	Finisher Punch	*CTL	
7504 111	Finisher Jam Clear	*CTL	
7504 120	Finisher 120	*CTL	Booklet finisher entrance off
7504 121	Finisher 121	*CTL	Booklet finisher entrance on
7504 122	Finisher 122	*CTL	Booklet finisher stack tray
7504 123	Finisher 123	*CTL	Booklet finisher folding off
7504 124	Finisher 124	*CTL	Booklet finisher folding on
7504 125	Finisher 125	*CTL	Booklet finisher staple
7504 126	Finisher 126	*CTL	Booklet finisher punch
7504 127	Finisher 127	*CTL	Booklet finisher transport motor
7504 128	Finisher 128	*CTL	Booklet finisher paddle motor
7504 129	Finisher 129	*CTL	Booklet finisher stapler/folder motor
7504 130	Finisher 130	*CTL	Booklet finisher fence motor
7504 131	Finisher 131	*CTL	Booklet finisher regular tray

7506	[Jam Paper Size]		
7506 005	A4 LEF	*CTL	Displays the number of jams according to the paper size. [0 to 9999 / 0 / 1 sheet/step]
7506 006	A5 LEF	*CTL	
7506 014	B5 LEF	*CTL	
7506 038	LT LEF	*CTL	
7506 044	HLT LEF	*CTL	
7506 132	A3 SEF	*CTL	
7506 133	A4 SEF	*CTL	
7506 134	A5 SEF	*CTL	
7506 141	B4 SEF	*CTL	
7506 142	B5 SEF	*CTL	
7506 160	DLT SEF	*CTL	
7506 164	LG SEF	*CTL	
7506 166	LT SEF	*CTL	
7506 172	HLT SEF	*CTL	
7506 255	Others	*CTL	

7803	[PM Counter Display]		
	(Sheets or Rotations, Unit, [Color]) Dev.: Development Unit, PF: Paper Feed Rollers, Fusing: Fusing Unit, Transfer: Transfer Unit		
Displays the number of sheets printed for each current maintenance unit.			
7803 001	Paper		*BCU [0 to 9999999 / 0 / 1 sheet/step]
7803 002	S: PCU [K]		*BCU PM counters click up based on the number of A4
7803 003	S: PCU [Y]		*BCU (LT) LEF size sheets printed. Therefore, the A3
7803 004	S: PCU [M]		*BCU (DLT) Double Count is activated. The Double
7803 005	S: PCU [C]		*BCU Count cannot be deactivated.
7803 006	S: Dev. [K]		*BCU When a unit is replaced, the machine
7803 007	S: Dev. [Y]		*BCU automatically detects that the new unit is installed.
7803 008	S: Dev. [M]		*BCU Then, the current PM counter value is
7803 009	S: Dev. [C]		*BCU automatically moved to the PM Counter - Previous
7803 011	PF By-pass		*BCU (SP7-906-1 to 10) and is reset to "0".
7803 012	PF Tray 1		*BCU The total number of sheets printed with the last
7803 013	PF Tray 2		*BCU unit replaced can be checked with SP7-906-1 to
7803 014	PF Tray 3		*BCU 10.
7803 015	PF Tray 4		*BCU SP7-803-001: This shows the number of pages
7803 016	S: Fusing		*BCU printed.
7803 017	S: Transfer		*BCU NOTE: The LCT is counted as the 3rd feed
station.			
Displays the number of revolutions of motors or clutches for each current maintenance unit. [0 to 9999999 / 0 / 1 revolution/step]			
When a unit is replaced, the machine automatically detects that the new unit is installed. Then, the current PM counter value is automatically moved to the PM Counter - Previous (SP7-906-11 to 20) and is reset to "0". The total number of revolutions made with the last unit replaced can be checked with SP7-906-11 to 20.			
7803 018	R: PCU [K]		*BCU
7803 019	R: PCU [Y]		*BCU
7803 020	R: PCU [M]		*BCU
7803 021	R: PCU [C]		*BCU
7803 022	R: Dev. [K]		*BCU
7803 023	R: Dev. [Y]		*BCU
7803 024	R: Dev. [M]		*BCU
7803 025	R: Dev. [C]		*BCU
7803 027	R: Fusing		*BCU
7803 028	R: Transfer		*BCU
Displays the number of sheets printed until the waste toner bottle becomes full or toner runs out. When a unit is replaced, the machine automatically detects that the new unit is installed. Then, the current PM counter value is automatically moved to the PM Counter - Previous (SP7-906-21 to 25) and is reset to "0". The total number of revolutions made with the last unit replaced can be checked with SP7-906-21 to 25.			
7803 029	S: Waste Toner		*BCU [0 to 9999999 / - / 1 sheet/step]
7803 030	S: Toner [K]		*BCU
7803 031	S: Toner [Y]		*BCU
7803 032	S: Toner [M]		*BCU
7803 033	S: Toner [C]		*BCU
Displays the total operating time for the toner attraction pump.			
7803 034	TonerSupply[K]		*BCU [0 to 9999999 / - / 1 s/step]
7803 035	TonerSupply[Y]		*BCU
7803 036	TonerSupply[M]		*BCU
7803 037	TonerSupply[C]		*BCU

7803	[PM Counter Display]		
	(Sheets or Rotations, Unit, [Color]) Dev.: Development Unit, PF: Paper Feed Rollers, Fusing: Fusing Unit, Transfer: Transfer Unit		
<p>Displays the value given by the following formula: $(\text{Current revolution} \div \text{Target revolution}) \times 100$, where “Current revolution” is the values of SP7-803-18 through 27 and “Target revolution” is the fixed values. This shows how much of the unit’s expected lifetime has been used up. The R% counter is based on rotations, not prints. If the number of rotations reaches the limit, the machine enters the end condition for that unit. If the print count lifetime is reached first, the machine also enters the end condition, even though the R% counter is still less than 100%.</p>			
7803 038	R(%): PCU [K]	*BCU	
7803 039	R(%): PCU [Y]	*BCU	
7803 040	R(%): PCU [M]	*BCU	
7803 041	R(%): PCU [C]	*BCU	
7803 042	R(%): Dev [K]	*BCU	
7803 043	R(%): Dev [Y]	*BCU	
7803 044	R(%): Dev [M]	*BCU	
7803 045	R(%): Dev [C]	*BCU	
7803 047	R(%): Fusing	*BCU	
7803 048	S: Trans Cln	*BCU	
7803 049	R: Trans Cln	*BCU	

7804	[PM Counter Reset]		
	(Unit, [Color]) Dev.: Development Unit, PF: Paper Feed Rollers, Transfer: Transfer Unit		
7804 001	Paper		<p>Clears the PM counter. Press the Enter key after the machine asks “Execute?”. When a unit is replaced, the machine automatically detects that the new unit is installed. Then, the current PM counter value is automatically moved to the b PM Counter - Previous (SP7-906-1 to 35) and is reset to “0”. NOTE: The LCT is counted as the 3rd feed station.</p>
7804 002	PCU [K]		
7804 003	PCU [Y]		
7804 004	PCU [M]		
7804 005	PCU [C]		
7804 006	Dev. [K]		
7804 007	Dev. [Y]		
7804 008	Dev. [M]		
7804 009	Dev. [C]		
7804 011	PF By-pass		
7804 012	PF Tray 1		
7804 013	PF Tray 2		
7804 014	PF Tray 3		
7804 015	PF Tray 4		
7804 016	Fusing		
7804 017	Transfer		
7804 018	Trans Cln		
7804 050	All		

Service Tables

7807	[SC/Jam Clear] SC/Jam Counter Clear		
	Clears the counters related to SC codes and paper jams.		

7832	[Diag. Result] Diagnostic Result	*CTL	
	Displays the result of the diagnostics. To scroll the return codes, press the up-arrow key or the down-arrow key.		

7833	[Coverage] Pixel Coverage Ratio		
Displays the image coverage ratio for each color of the last output. This SP mode displays the "coverage ratio" of the output, i.e. the ratio of the total pixel area of the image data to the total printable area on the paper. Note that this value is not directly proportional to the amount of toner consumed, although of course it is one factor that affects this amount. The other major factors involved include: the type, total image area and image density of the original, toner concentration and developer potential.			
7833 001	Last [K]	*BCU	[0 to 100.00 / - / 0.01 %/step]
7833 002	Last [C]	*BCU	
7833 003	Last [M]	*BCU	
7833 004	Last [Y]	*BCU	
Displays accumulated average value of image coverage ratio for each color. SP7-833-005 to 008 vs SP8-831-001 to 004 The averages for K (SP7-833-005 and SP8-831-001) are the same. For CMY, SP8-831 does not include black-and-white pages in the middle of a color job. However, SP7-833 does include these pages in the average. As a result, the readings of SP7-833 will be lower, because these averages include pages for which there is zero for CMY, but the averages calculated for SP8-831 do not include these pages.			
7833 005	Average [K]	*BCU	[0 to 100.00 / - / 0.01 %/step]
7833 006	Average [C]	*BCU	
7833 007	Average [M]	*BCU	
7833 008	Average [Y]	*BCU	
Displays the total number of toner cartridges replaced.			
7833 011	Toner [K]	*BCU	[0 to 65535 / - / 1 cartridge/step]
7833 012	Toner [C]	*BCU	
7833 013	Toner [M]	*BCU	
7833 014	Toner [Y]	*BCU	

7834	[Coverage Clear]		
7834 001	Average		Resets the average coverage counters.
7834 002	Toner		Resets the toner cartridge counters.
7834 003	S: PREV Toner		Resets the sheet counters of the previous cartridges. The sheet counters count the number of sheets printed with a toner cartridge.
7834 004	S: Coverage 0-100		Resets the coverage counters.
7834 255	All		Executes SP7-834-001 through 004.

7836	[Total Memory Size]		
Shows the total storage size.			

7901	[Assert Info]		
7901 001	File Name		Records the location where a problem is detected in the program. The data stored in this SP is used for problem analysis. DFU
7901 002	# of Lines		
7901 003	Location		

7904	[Supply Alert] Supply Alert Setting		
	Sets the supply alert timing.		
7904 001	M Kit	*BCU	[0 to 2 / 1 / 1 /step] Alphanumeric
7904 002	Fuser	*BCU	0: Earlier
7904 003	PCU	*BCU	1: Default
7904 004	Dev	*BCU	2: Nearly Limit

7905	[Alert Display]		
7905 006	Fus Life	*BCU	Japan Use Only
7905 028	M kit: Bk	*BCU	Japan Use Only
7905 029	M kit: Cl	*BCU	Japan Use Only

7906	[PMCounter-PREV] PM Counter - Previous		
	(Sheets or Rotations, Unit, [Color]), Dev.: Development Unit		
7906 001	S: PCU [K]	*BCU	Displays the number of sheets printed with the previous maintenance units. [0 to 9999999 / 0 / 1 sheet/step]
7906 002	S: PCU [Y]	*BCU	
7906 003	S: PCU [M]	*BCU	
7906 004	S: PCU [C]	*BCU	
7906 005	S: Dev. [K]	*BCU	
7906 006	S: Dev. [Y]	*BCU	
7906 007	S: Dev. [M]	*BCU	
7906 008	S: Dev. [C]	*BCU	
7906 010	S: Fusing	*BCU	
7906 011	R: PCU [K]	*BCU	
7906 012	R: PCU [Y]	*BCU	
7906 013	R: PCU [M]	*BCU	
7906 014	R: PCU [C]	*BCU	
7906 015	R: Dev. [K]	*BCU	
7906 016	R: Dev. [Y]	*BCU	
7906 017	R: Dev. [M]	*BCU	
7906 018	R: Dev. [C]	*BCU	
7906 020	R: Fusing	*BCU	
7906 021	S: Waste Toner	*BCU	Displays the number of sheets printed with the previous maintenance unit or toner cartridge. [0 to 9999999 / 0 / 1 sheet/step]
7906 022	S: Toner [K]	*BCU	
7906 023	S: Toner [Y]	*BCU	
7906 024	S: Toner [M]	*BCU	
7906 025	S: Toner [C]	*BCU	
7906 026	R(%): PCU [K]	*BCU	Displays the value given by the following formula: (Current count ÷ Yield count) x 100, where “Current count” is the current values in the counter for the part, and “Yield count” is the recommended yield. [0 to 999 / 0 / 1 %/step]
7906 027	R(%): PCU [Y]	*BCU	
7906 028	R(%): PCU [M]	*BCU	
7906 029	R(%): PCU [C]	*BCU	
7906 030	R(%): Dev [K]	*BCU	
7906 031	R(%): Dev [Y]	*BCU	
7906 032	R(%): Dev [M]	*BCU	
7906 033	R(%): Dev [C]	*BCU	
7906 035	R(%): Fusing	*BCU	

7907	[Check Sum]		
7907 001	Engine Main	*BCU	Displays the check sum of the firmware.
7907 002	Engine MUSIC	*BCU	

7910	[ROM No] ROM Part Number		
	Displays the part number of the ROM..		
7910 001	System	7910 156	R55
7910 002	Engine	7910 157	RTIFF
7910 007	Finisher	7910 158	PCL
7910 009	Bank	7910 159	PCLXL
7910 010	LCT	7910 160	MSIS
7910 011	Mail Box	7910 161	MSIS (OPTION)
7910 013	Duplex	7910 162	PDF
7910 014	MUSIC	7910 163	BMLinkS
7910 018	NIB	7910 164	PictBridge
7910 021	DSP MUSIC	7910 180	FONT
7910 022	BIOS	7910 181	FONT 1
7910 023	HDD Format Option	7910 182	FONT 2
7910 131	Bluetooth	7910 183	FONT 3
7910 150	RPCS	7910 200	Factory
7910 151	PS	7910 202	Net File
7910 152	RPDL	7910 204	Printer
7910 153	R98	7910 209	Test Suite
7910 154	R16	7910 210	MIB
7910 155	RPGL	7910 211	Web System

7911	[Firmware Ver.] Firmware Version		
	Displays the firmware version.		
7911 001	System	7911 156	R55
7911 002	Engine	7911 157	RTIFF
7911 007	Finisher	7911 158	PCL
7911 009	Bank	7911 159	PCLXL
7911 010	LCT	7911 160	MSIS
7911 011	Mail Box	7911 161	MSIS (OPTION)
7911 013	Duplex	7911 162	PDF
7911 014	MUSIC	7911 163	BMLinkS
7911 018	NIB	7910 164	PictBridge
7911 021	DSP MUSIC	7911 180	FONT
7911 022	BIOS	7911 181	FONT 1
7910 023	HDD Format Option	7911 182	FONT 2
7911 131	Bluetooth	7911 183	FONT 3
7911 150	RPCS	7911 200	Factory
7911 151	PS	7911 202	Net File
7911 152	RPDL	7911 204	Printer
7911 153	R98	7911 209	Test Suite
7911 154	R16	7911 210	MIB
7911 155	RPGL	7911 211	Web System

SP8-XXX (Data Log 2)

The counters in Data Log 2 are commonly used by multiple machines. Data Log 2 includes the counters of the functions or units that are not supported by the machine. The counters in Data Log 2 are cleared by SP5-801 (Memory Clear).

Keys and abbreviations in Data Log 2**• Program-related keys and abbreviations**

T:	the grand total of the counters of all application programs
C:	the counter of the copier application program excluding the events related to the document server
F:	the counter of the facsimile application program excluding the events related to the document server
P:	the counter of the printer application program excluding the events related to the document server
S:	the counter of the scanner application program excluding the events related to the document server
L:	the counter of the document server (local storage)
O:	the counter of other application programs including remote application programs

• Program-independent keys and abbreviations

/	by ("T:Jobs/Apl" means the total Jobs by Application.)
>	or more ("2>" means two or more.)
AddBook	address book
Apl	application program
B/W	black & white
Bk	black
C	cyan
ColCr	color create
ColMode	color mode
Comb	combine
Comp	compression
Deliv	delivery
DesApl	designated application program (The designated application program is the application program that stores the data or information on the document server, for example.)
Dev Counter	development count; the number of pages developed
Dup, Duplex	duplex printing
Emul	emulation
FC	full color
FIN	finish, post-print processing
Full Bleed	without margin
GenCopy	generation copy
GPC	get print counter (The get print counter starts counting when the number of processed pages exceeds 10. For example, when 12 pages are processed, the get print counter shows 2.)
IFax	Internet fax
ImgEdt	image editing performed on the original with the copier GUI (Image editing includes, for example, border removal, adding stamps, and page numbering.)
K	black in the YMCK mode
LS	local storage; document server
LSize	large size
Mag	magnification
MC	one color
NRS	new remote service; NRS
Org	original for scanning

OrgJam	original jam
Palm 2	Print Job Manager/Desk Top Editor (A pair of utility programs that distribute print jobs evenly among the printers on the network and processes files.)
PC	personal computer
PGS	pages (Duplex printing is counted as two. A3/DLT simplex is counted as two if the A3/DLT double-count program is validated.)
PJob	print job
Ppr	paper
PrtJam	printer (plotter) jam
PrtPGS	print pages
R	red toner remaining (Currently, no machine supports this function.)
Rez	resolution
SC	service condition code; SC code
Scn	scan
Sim, Simplex	simplex, printing on one side.
S-to-Email	scan-to-e-mail
SMC	SMC report printed by SP5-990
Svr	server
TonEnd	toner end
TonSave	toner save
TXJob	send, transmission
YMC	yellow, magenta, and cyan
YMCK	yellow, magenta, cyan, and black

8001	T: Total Jobs	*CTL	The number of times the application program starts a job [0~9999999/ 0 / 1]
8004	P: Total Jobs	*CTL	

- The jobs interrupted by paper jams or some other errors are also counted.
- The jobs executed by SPs are not counted.
- When using secure printing (when a password is required to start the print job), the job is counted at the time when either “Delete Data” or “Specify Output” is specified.
- When the user prints a report (user code list, for example), the O: counter increments.

8021	T: Pjob/LS	*CTL	The number of times the application program stores data on the document server [0~9999999/ 0 / 1]
8024	P: Pjob/LS	*CTL	
8027	O: Pjob/LS	*CTL	

- When images stored on the document server by a network application (including Palm 2), are printed with another application, the O: counter increments.

8031	T: Pjob/DesApl	*CTL	The number of times the application program retrieves data from the document server [0~9999999/ 0 / 1]
8034	P: Pjob/DesApl	*CTL	
8037	O: Pjob/DesApl	*CTL	

- When documents already stored on the document server are printed, the counter of the application program that executes the print job increases.

8061	T: FIN Jobs	*CTL	The number of times the application program uses the finisher [0~9999999/ 0 / 1]
8064	P: FIN Jobs	*CTL	
8067	O: FIN Jobs	*CTL	
001	Sort	The number of times the application program starts the sort mode	
002	Stack	The number of times the application program starts the tack mode	
003	Staple	The number of times the application program starts the staple mode	
004	Booklet	The number of times the application program starts the booklet mode NOTE: The counter of the staple mode (003) can also increase.	
005	Z-Fold	The number of times the application program starts the Z-fold mode NOTE: The booklet mode is not included.	
006	Punch	The number of times the application program starts the punch mode NOTE: The counter of the printer application program (P:) can also increase.	
007	Other	(Reserved)	

8071	T: Jobs/PGS	*CTL	The number of jobs that try to output a specific number of pages [0~9999999/ 0 / 1]
8074	P: Jobs/PGS	*CTL	
8077	O: Jobs/PGS	*CTL	
001	1 Page	008	21~50 Pages
002	2 Pages	009	51~100 Pages
003	3 Pages	010	101~300 Pages
004	4 Pages	011	301~500 Pages
005	5 Pages	012	501~700 Pages
006	6~10 Pages	013	701~1000 Pages
007	11~20 Pages	014	1001~ Pages

- The jobs interrupted by paper jams or some other errors are also counted.
- If a job is suspended and restarted later, the job is seen as one job.
- If the finisher runs out of staples during stapling, the job is counted at the time the error occurs.
- The first test print and subsequent test prints to adjust settings are added to the number of pages of the copy job (SP8-072).

Service Tables

8381	T: Total PrtPGS	*CTL	The number of sheets that the application program tries to print (excluding the pages printed in the SP mode) [0~9999999/ 0 / 1]
8384	P: Total PrtPGS	*CTL	
8387	O: Total PrtPGS	*CTL	

- A3/DLT simplex is counted as two if the A3/DLT double-count program is validated.
- The following pages are not counted as printed pages:
 - Blank pages in a duplex printing job
 - Blank pages inserted as document covers, chapter title sheets, and slip sheets
 - Reports printed to confirm counts
 - All reports done in the service mode (service summaries, engine maintenance reports, etc.)
 - Test prints for machine image adjustment
 - Error notification reports
 - Partially printed pages as the result of a copier jam

8391	LSize PrtPGS	*CTL	The number of sheets printed on A3/DLT and larger sizes [0~9999999/ 0 / 1]
-------------	--------------	------	---

8411	Prints/Duplex	*CTL	The number of sheets used in duplex printing [0~9999999/ 0 / 1]
-------------	---------------	------	--

- The counter increases by +1 when both sides (front/back) are printed. The counter does not increase when one of the two sides is not printed (e.g., the last page of the documents that have three pages, five pages, seven pages, and so on).

8421	T: PrtPGS/Dup Comb	*CTL	The number of sheets used in binding and combining [0~9999999/ 0 / 1]
8424	P: PrtPGS/Dup Comb	*CTL	
8427	O: PrtPGS/Dup Comb	*CTL	
001	Simplex> Duplex		
004	Simplex Combine		
005	Duplex Combine		
006	2>	2 pages on 1 side (2-Up)	
007	4>	4 pages on 1 side (4-Up)	
008	6>	6 pages on 1 side (6-Up)	
009	8>	8 pages on 1 side (8-Up)	
010	9>	9 pages on 1 side (9-Up)	
011	16>	16 pages on 1 side (16-Up)	
012	Booklet		
013	Magazine		

- These counters are useful for the users who want to know how much paper they have saved.
- Partially printed sheets are also counted as 1 page (e.g, the last page in the 4-Up mode is only partially printed when the documents have 5, 6, or 7 pages, 9, 10, or 11 pages, 13, 14, or 15 pages, and so on.).
- Here is a summary of how the counters work in the booklet and magazine modes.

Booklet		Magazine	
Original Pages	Count	Original Pages	Count
1	1	1	1
2	2	2	2
3	2	3	2
4	2	4	2
5	3	5	4
6	4	6	4
7	4	7	4
8	4	8	4

Service Tables

8431	T: PrtPGS/ImgEdt	*CTL	The number of pages that the application program handles in a specific way [0~9999999/ 0 / 1]
8434	P: PrtPGS/ImgEdt	*CTL	
8437	O: PrtPGS/ImgEdt	*CTL	
001	Cover/Slip Sheet	The number of cover sheets or slip sheets inserted NOTE: A duplex-printed cover is counted as two.	
002	Series/Book	The number of pages printed in series (one side) or in the booklet mode	
003	User Stamp	The number of pages where stamps were applied (including page numbering and date stamping)	

8441	T: PrtPGS/Ppr Size	*CTL	The number of sheets of a specific paper size that the application program uses [0~9999999/ 0 / 1]
8444	P: PrtPGS/Ppr Size	*CTL	
8447	O: PrtPGS/Ppr Size	*CTL	
001	A3		007 LG
002	A4		008 LT
003	A5		009 HLT
004	B4		010 Full Bleed
005	B5		254 Other (Standard)
006	DLT		255 Other (Custom)

- These counters do not distinguish between LEF and SEF.

8451	PrtPGS/Ppr Tray	*CTL	The number of sheets fed from a specific tray [0~9999999/ 0 / 1]
001	Bypass		Bypass Tray
002	Tray 1		Copier
003	Tray 2		Copier
004	Tray 3		Paper Tray Unit/LCT (Optional)
005	Tray 4		Paper Tray Unit (Optional)
006	Tray 5		(Not used)
007	Tray 6		(Not used)
008	Tray 7		(Not used)
009	Tray 8		(Not used)
010	Tray 9		(Not used)

8461	T: PrtPGS/Ppr Type	*CTL	The number of sheets of specific paper types [0~9999999/ 0 / 1]
8464	P: PrtPGS/Ppr Type	*CTL	
001	Normal		005 Normal (Back)
002	Recycled		006 Thick (Back)
003	Special		007 OHP
004	Thick		008 Other

- These counters increase when the paper is output. On the other hand, the PM counter increases (to measure the service life of each feed roller) when the paper is fed.
- Blank sheets (covers, chapter covers, slip sheets) are also counted.
- During duplex printing, a sheet printed on two sides and a sheet printed on one side are both counted as 1.

8471	PrtPGS/Mag	*CTL	The number of pages magnified or reduced [0~9999999/ 0 / 1]
001	~49%		004 101%~200%
002	50%~99%		005 201% ~
003	100%		

- Some application programs (on the computer) can specify the magnification setting of the printer driver (e.g., MS Excel). In a case like this, SP8-471 recognizes the setting and increases the corresponding counter. Other application programs can magnify or reduce the print images on their own. In a case like this, SP8-471 does not recognize the magnification setting of the application programs and increase the counter of 100%.
- Magnification adjustment conducted on the document server is not counted.
- Blank cover sheets and slip sheets are regarded as 100%.

8481	T: PrtPGS/TonSave	*CTL	The number of pages printed with the toner save feature activated [0~9999999/ 0 / 1]
8484	P: PrtPGS/TonSave	*CTL	

- These counters display the same result.

8501	T: PrtPGS/Col Mode	*CTL	The number of pages printed in a specific color mode [0~9999999/ 0 / 1]
8504	P: PrtPGS/Col Mode	*CTL	
001	B/W		003 Full Color
002	Single Color		

8511	T: PrtPGS/Emul	*CTL	The number of pages printed by the printer emulation mode [0~9999999/ 0 / 1]
8514	P: PrtPGS/Emul	*CTL	
001	RPCS		008 RTIFF
002	RPDL		009 PDF
003	PS3		010 PCL5e/5c
004	R98		011 PCL XL
005	R16		012 IPDL-C
006	GL/GL2		013 BM-Links (for local models only)
007	R55		014 Other

- These counters display the same result.

8521	T: PrtPGS/FIN	*CTL	The number of pages processed by the finisher [0~9999999/ 0 / 1]
8524	P: PrtPGS/FIN	*CTL	[0~9999999/ 0 / 1]
001	Sort		005 Z-Fold
002	Stack		006 Punch
003	Staple		007 Other
004	Booklet		

- Even if the pages are too many for the finisher to staple, all pages are counted (including unstapled pages).
- The counter of stapling (003) increases by +1 when the paper is transported from the printer to the tray of the finisher. Even if a paper jam occurs on this path, the counter (003) increases. If the same job is retried, the counter (003) increases once again.

8531	Staples	*CTL	The number of staples [0~9999999/ 0 / 1]
-------------	---------	------	---

8581	T: Counter	*CTL	The number of outputs in a specific color mode [0~9999999/ 0 / 1]
001	Total		010 Total: Color
002	Total: Full Color		011 Total: B/W
003	B&W/Single Color		012 Full Color: A3
004	Development: CMY		013 Full Color: ~B4
005	Development: K		014 Full Color Print
008	Print: Color		015 Mono Color Print
009	Print: B/W		

8584	P: Counter	*CTL	The number of outputs in a specific color mode [0~9999999/ 0 / 1]
001	B/W		003 Full Color
002	Single Color		

8591	O: Counter	*CTL	The number of A3/DLT, duplex printing, or staples [0~9999999/ 0 / 1]
001	A3/DLT		003 Staple
002	Duplex		

- Note that these counters are not for the printer application program.

8771	Dev Counter	*CTL	The number of rotations of the development rollers [0~9999999/ 0 / 1]
001	Total		004 M
002	K		005 C
003	Y		

8781	Toner Botol Info.	*BCU	The number of toner bottles (cartridges) already replaced [0~9999999/ 0 / 1]
001	Toner [BK]		003 Toner [M]
002	Toner [Y]		004 Toner [C]

- SP7-833-011 through 014 and SP8-781-001 through 004 display the same results.

8801	Toner Remain	*CTL	The percentage of the remaining toner [0~100/ 0 / 1]
001	K		003 M
002	Y		004 C

8831	Coverage	*BCU	The average coverage [0~100/ 0 / 1]
001	Average [BK]		003 Average [M]
002	Average [Y]		004 Average [C]

- SP8-831 displays the image coverage ratio for each color of the last output. This SP mode displays the coverage ratio of the output, i.e. the ratio of the total pixel area of the image data to the total printable area on the paper. Note that this value is not directly proportional to the amount of toner consumed, although of course it is one factor that affects this amount. The other major factors involved include: the type, total image area and image density of the original, toner concentration and developer potential.
- SP8-831-001 through 004 and SP7-833-005 through 008 display the same results.

8841	Coverage	*BCU	The coverage of the latest print [0~100/ 0 / 1]
001	Last [BK]		003 Last [M]
002	Last [Y]		004 Last [C]

- SP8-841-001 through 004 and SP7-833-001 through 004 display the same results.

8851	Coverage: 0-10%	*BCU	The number of scanned sheets of a specific coverage ratio [0~9999999/ 0 / 1]
8861	Coverage: 11-20%	*BCU	
8871	Coverage: 21-30%	*BCU	
8881	Coverage: 31%-	*BCU	
001	S: BK		003 S: M
002	S: Y		004 S: C

- For example, SP8-851-001 displays the number of scanned sheets whose black-coverage ratio is 0 percent through 10 percent. SP8-881-004 displays the number of scanned sheets whose cyan-coverage ratio is 31 percent or higher.

8891	PM Counter	*BCU	The number of sheets output by the scanner application program [0~9999999/ 0 / 1]
001	S: Toner [BK]		003 S: Toner [M]
002	S: Toner [Y]		004 S: Toner [C]

8901	PM Counter-PREV	*BCU	The number of sheets output by the scanner application program with the previously replaced units [0~9999999/ 0 / 1]
001	S: Toner [BK]		003 S: Toner [M]
002	S: Toner [Y]		004 S: Toner [C]

8911	PM Counter-Before	*BCU	The number of sheets output by the scanner application program with the replaced units before previous units. [0~9999999/ 0 / 1]
001	S: Toner [BK]		003 S: Toner [M]
002	S: Toner [Y]		004 S: Toner [C]

8941	Machine Status	*CTL	The amount of time the machine spends in a specific mode [0~9999999/ 0 / 1]
001	Operation Time		The engine is operating. The counter does not include the time when the data is being saved in the HDD (while engine is not operating).
002	Standby Time		The engine is not operating. The counter includes the time when the data is being saved in the HDD. The counter does not include the time when the machine is in the Energy Saver Mode, the Low Power Mode, or the Off Mode.
003	Energy Save Time		The machine is in the Energy Saver Mode. The counter includes the time when the background printing is being executed.
004	Low Power Time		The machine is in the Low Power Mode. The counter includes the time when the engine is on in the Energy Saver Mode. The counter also includes the time when the background printing is being executed.
005	Off Mode Time		The machine is in the Off Mode. The counter includes the time when the background printing is being executed. The counter does not include the time when the main power switch is off.
006	SC		The total time caused by SC codes
007	PrtJam		The total time caused by plotter jams
008	OrgJam		The total time caused by original jams
009	PM Unit End		The total time caused by supply unit ends

5.3.2 MEMORY CLEAR/COUNTER CLEAR

The table lists the data that is reset or deleted with SP5-801, SP5-998. The serial number information, meter charge setting (SP5-930), and meter charge counters (SP8-58x) are not cleared.

NOTE: In this section (5.3.2), the letter “x” represents a whole number from “0” to “9”.

Service Program		Reset or Deleted
5801 001	All Clear	Resets all correction data for process control and all software counters, and returns all modes and adjustments to their default values.
5801 002	ENG All	Clears the engine settings.
5801 003	SCS	SP5-104, 812, 961 SP7-401, 502, 504, 506 SP8-00x, 02x, 03x, 06x, 07x, 42x, 43x, 44x, 451, 46x, 471, 48x, 51x, 52x, 771, 781, 801, 831, 841, 851, 861, 871, 881, 891, 901, 911, 941
5801 004	IMH	No SP modes are cleared. All files stored in the HDD are deleted.
5801 005	MCS	No SP modes are cleared.
5801 008	PRT	Service settings: <ul style="list-style-type: none"> • Bit switches • Gamma settings (User & Service) • Toner Limit User settings: <ul style="list-style-type: none"> • Tray Priority • Menu Protect • System Setting other than energy saver settings • I/F Setup (I/O Buffer and I/O Timeout) • PCL Menu
5801 010	Web Service	Clears the netfile application management files and thumbnails, and initializes the job login ID.
5801 011	NCS	All setting of Network Setup (User Menu)
5801 014	Clear DCS Settings	Initializes the DCS (Delivery Control Service) settings.
5801 015	Clear UCS Settings	Initializes the UCS (User Information Control Service) settings.
5801 016	MIRS Setting	Initializes the MIRS (Machine Information Report Service) settings.
5801 017	CCS	Initializes the CCS (Certification and Charge-control Service) settings.
5801 018	SRM	Initializes the SRM settings
5801 019	LCS Setting	Initializes the LCS settings
5998 001	ENG Setting	All engine related SP modes other than the following: <ul style="list-style-type: none"> • Serial number information • SP modes related to meter charge • Counters and logging data
5998 002	ENG Counter	All counters and logging data related to engine

5.3.3 INPUT CHECK TABLE

When entering the Input Check mode, 8 digits display the result for a section. Each digit corresponds to a different device as shown in the table.

Bit No.	7	6	5	4	3	2	1	0
Result	0 or 1	0 or 1	0 or 1	0 or 1	0 or 1	0 or 1	0 or 1	0 or 1

SP5-803 -XXX	Bit	Description	Reading	
			0	1
1	Paper Tray 1			
	0	Paper End Sensor	Paper end	Paper detected
	1	Paper Lift Sensor	Deactivated	Activated (Actuator not inside sensor)
	2	Paper Height Sensor 1	See Table 1.	
	3	Paper Height Sensor 2		
4	Tray Set	Not set	Set	
2	Paper Tray 2			
	0	Paper End Sensor	Paper end	Paper detected
	1	Paper Lift Sensor	Deactivated	Activated (Actuator not inside sensor)
	2	Paper Height Sensor 1	See Table 1. 1: Activated (Actuator inside sensor)	
	3	Paper Height Sensor 2		
	4	Paper Size Switch 1	See Table 2. 1: Pushed	
	5	Paper Size Switch 2		
6	Paper Size Switch 3			
7	Paper Size Switch 4			
3	By-pass Table			
	0	Paper End Sensor	Paper end	Paper detected
	1	Paper Size 1	See Table 3.	
	2	Paper Size 2		
	3	Paper Size 3		
4	Paper Size 4			
4	Doors			
	0	Front Door Switch	Opened	Closed
	1	Left Door Switch	Opened	Closed
	2	Right Door Switch	Opened	Closed
	3	Vertical Transport Switch	Opened	Closed
	4	Duplex Inverter Unit Switch	Opened	Closed
5	Right Door Switch (LCT/PFU)	Opened	Closed	
5	Paper Feed			
	0	Relay Sensor	Paper not detected	Paper detected
	1	Vertical Transport Sensor	Paper not detected	Paper detected
	2	Upper Relay Sensor (PFU)	Paper not detected	Paper detected
	3	Lower Relay Sensor (PFU)	Paper not detected	Paper detected
	4	Registration Sensor	Paper not detected	Paper detected
	5	Duplex Inverter Sensor	Paper not detected	Paper detected
6	Duplex Feed Sensor	Paper not detected	Paper detected	

SP5-803 -XXX	Bit	Description	Reading	
			0	1
6	Paper Exit			
	0	Fusing Exit Sensor	Paper not detected	Paper detected
	1	Paper Exit Sensor	Paper not detected	Paper detected
	2	Duplex Exit Sensor 1	Paper not detected	Paper detected
	3	Duplex Exit Sensor 2	Paper not detected	Paper detected
	4	Duplex Exit Sensor 3	Paper not detected	Paper detected
	5	Exit Upper Limit Sensor	Not full	Full
7	Fusing Unit			
	0	Fusing Unit (Set)	Not set	Set
	1	Fusing Unit (New)	0 to 1 : New unit installed	
	2	Oil Supply Unit (Set)	Set	Not set
	3	Oil Supply Unit (New)	1 to 0 : New unit installed	
	4	European Version	US	Europe
	5	Waste Oil Bottle Set Sensor	Not Set	Set
	6	Waste Oil Sensor	Not full	Full
8	Motor Lock			
	0	Development Drive Motor - CMY	Not locked	Locked
	1	Development Drive Motor - K	Not locked	Locked
	2	Fusing Fan Motor	Not locked	Locked
	3	Air Pump Motor - MY	Not locked	Locked
	4	Air Pump Motor - CK	Not locked	Locked
9	Dev. Unit/ PCU			
	0	Development Unit - K	Not set	Set
	1	Development Unit - C	Not set	Set
	2	Development Unit - M	Not set	Set
	3	Development Unit - Y	Not set	Set
	4	PCU - K	Not set	Set
	5	PCU - C	Not set	Set
	6	PCU - M	Not set	Set
	7	PCU - Y	Not set	Set
10	Toner End Sens			
	0	Black Toner	Not end	End
	1	Cyan Toner	Not end	End
	2	Magenta Toner	Not end	End
	3	Yellow Toner	Not end	End
13	Others			
	0	LD H.P. Sensor	Not H.P.	H.P.
	1	Transfer Belt Sensor	Not contact	Contact
	2	-	-	-
	3	Used Toner Sensor	Not full	Full
	4	Used Toner Bottle Set Sensor	Not set	Set
	5	Drum Gear Position Sensor - K	Deactivated	Activated (Actuator inside sensor)
6	Drum Gear Position Sensor - CMY	Deactivated	Activated (Actuator inside sensor)	

SP5-803 -XXX	Bit	Description	Reading	
			0	1
15	Mail Box 1			
	0	Tray 1 Paper Overflow Sensor	Not full	Full
	1	Tray 1 Paper Sensor	Paper not detected	Paper detected
	2	Tray 2 Paper Overflow Sensor	Not full	Full
	3	Tray 2 Paper Sensor	Paper not detected	Paper detected
	4	Tray 3 Paper Overflow Sensor	Not full	Full
	5	Tray 3 Paper Sensor	Paper not detected	Paper detected
	6	Tray 4 Paper Overflow Sensor	Not full	Full
16	Mail Box 2			
	0	Vertical Transport Sensor 1	Paper not detected	Paper detected
	1	Vertical Transport Sensor 2	Paper not detected	Paper detected
	2	Door Safety Switch	Opened	Closed

Table 1: Paper Height Sensor

Low: Deactivated, High: Activated (actuator inside sensor)

Remaining paper	Paper height sensor 1	Paper height sensor 2
Full	Low	Low
Nearly full	Low	High
Near end	High	High
Almost empty	High	Low

Table 2: Paper Size Switch (Tray 2)

0: Not pushed, 1: pushed

Models		Switch Location			
North America	Europe/Asia	1	2	3	4
11" x 17" SEF	11" x 17" SEF	0	1	0	0
A3 SEF	A3 SEF	1	0	1	0
8 1/2" x 14" SEF *1	B4 SEF *1	1	1	0	1
8 1/2" x 11" SEF *2	A4 SEF *2	0	1	1	0
11" x 8 1/2" LEF *3	11" x 8 1/2" LEF *3	1	0	1	1
A4 LEF	A4 LEF	0	1	0	1
B5 LEF	B5 LEF	0	0	1	0
A5 LEF	A5 LEF	0	0	0	1

NOTES:

*1: The machine detects either 8 1/2" x 14" SEF or B4 SEF, depending on the setting of SP 1-902-2

*2: The machine detects either 8 1/2" x 11" SEF or A4 SEF, depending on the setting of SP 1-902-3

*3: The machine detects either 11" x 8 1/2" LEF or B5 SEF, depending on the setting of SP 1-902-4

Table 3: Paper Size (By-pass Table)

Models		Bit No.			
North America	Europe/Asia	4	3	2	1
11" x 17" SEF	11" x 17" SEF	0	0	1	1
A3 SEF	A3 SEF	0	0	0	1
-	B4 SEF	0	0	1	0
8 1/2" x 11" SEF	A4 SEF	0	1	1	0
8" x 13" SEF	F SEF	0	1	0	0
-	A5 SEF	1	1	0	0
5 1/2" x 18 1/2" SEF	B6 SEF	1	0	0	0
Post Card	Post Card	0	0	0	0

5.3.4 OUTPUT CHECK TABLE

CH: Charge

PF: Paper Feed

TS: Toner Supply

CW: Clockwise

CCW: Counterclockwise

MB: 4-bin Mailbox (Not used in this machine)

DI: Duplex Inverter

SP5-804-XXX		Description
1	Lift M UP (1)	Tray 1 Lift Motor / UP
2	Lift M DOWN(1)	Tray 1 Lift Motor / DOWN
3	Lift M UP(2)	Tray 2 Lift Motor / UP
4	Lift M DOWN(2)	Tray 2 Lift Motor / DOWN
5	By-pass CL	By-pass Feed Clutch
6	Pick-up SOL	Pick-up Solenoid
7	PF CL (1)	Paper Feed Clutch - Tray 1
8	PF CL (2)	Paper Feed Clutch - Tray 2
9	PF GRP SOL	Grip Roller Release Solenoid
10	Regist CL	Registration Clutch
11	Junction SOL	Exit Junction Gate Solenoid
13	Fusing CL	Fusing Clutch
14	Wst Tn Vib M	Waste Toner Vibrator Motor
19	K Dev CL	Development Unit Clutch - K
20	C Dev CL	Development Unit Clutch - C
21	M Dev CL	Development Unit Clutch - M
22	Y Dev CL	Development Unit Clutch - Y
23	K Dev M H	Development Motor - K / High Speed
24	K Dev M M	Development Motor - K / Middle Speed
25	K Dev M L	Development Motor - K / Low Speed
26	K Dev M Card	Black Development Motor - Thick paper
27	FC Dev M H	Color Development Motor - High Speed
28	FC Dev M M	Color Development Motor - Middle Speed
29	FC Dev M L	Color Development Motor - Low Speed
30	TS CL [Y]	Toner Supply Clutch for Yellow
31	TS CL [M]	Toner Supply Clutch for Magenta
32	TS CL [C]	Toner Supply Clutch for Cyan
33	TS CL [K]	Toner Supply Clutch for Black
34	Valve SOL [K]	Air Flow Valve solenoid for Black
35	Valve SOL [C]	Air Flow Valve solenoid for Cyan
36	Valve SOL [M]	Air Flow Valve solenoid for Magenta
37	Valve SOL [Y]	Air Flow Valve solenoid for Yellow
38	Air Supply M [YM]	Air Supply Motor - yellow and magenta
39	Air Supply M [CK]	Air Supply Motor - cyan and black
40	Air Supply [Y]	Air Pump Motor and Valve for Yellow
41	Air Supply [M]	Air Pump Motor and Valve for Magenta
42	Air Supply [C]	Air Pump Motor and Valve for Cyan
43	Air Supply [K]	Air Pump Motor and Valve for Black
44	T End Sens [Y]	Toner End Sensor - Y

SP5-804-XXX		Description
45	T End Sens [M]	Toner End Sensor - M
46	T End Sens [C]	Toner End Sensor - C
47	T End Sens [K]	Toner End Sensor - K
50	PSU Fan	PSU Cooling Fan Motor
51	Fusing Fan H	Fusing Fan Motor / High Speed
52	Fusing Fan L	Fusing Fan Motor / Low Speed
53	M Fan	Laser Optics Housing Unit Cooling Fan
54	Belt M CW	Transfer Belt Contact Motor / Clockwise
55	Belt M CCW	Transfer Belt Contact Motor / Counterclockwise
56	Belt M Break	Transfer Belt Contact Motor / Break
57	Fusing Relay	Fusing Relay
58	Heat Lamp	Heating Roller Fusing Lamp
59	Pressure Lamp	Pressure Roller Fusing Lamp
61	K PCU Fan: H	PCU Fan Motor for Black / High Speed
62	K PCU Fan: L	PCU Fan Motor for Black / Low Speed
65	Drum M L CW	Drum Drive Motors (K & CMY) and Transfer belt Drive Motor / Low Speed / Clockwise
66	Drum M M CW	Drum Drive Motors (K & CMY) and Transfer belt Drive Motor / Middle Speed / Clockwise
67	Drum M H CW	Drum Drive Motors (K & CMY) and Transfer belt Drive Motor / High Speed / Clockwise
74	PF M L CW	Paper Feed Motor / Low Speed / Clockwise
75	PF M M CW	Paper Feed Motor / Middle Speed / Clockwise
76	PF M H CW	Paper Feed Motor / High Speed / Clockwise
77	PF M Feed L	Paper Feed Motor / Low Speed
78	PF M Feed M	Paper Feed Motor / Middle Speed
79	PF M Feed H	Paper Feed Motor / High Speed
80	By-Pass M L CW	By-pass Motor / Low Speed / Clockwise
81	By-Pass M M CW	By-pass Motor / Middle Speed / Clockwise
82	By-Pass M H CW	Paper Feed Motor / High Speed / Clockwise
83	By-pass M C CW	By-pass Motor / Thick Paper or OHP mode / Clockwise
84	Counter: K	
85	Counter: YMC	
89	CH DC [Y]	Charge DC Bias for Yellow / 162 mm/s
90	CH DC [M]	Charge DC Bias for Magenta / 162 mm/s
91	CH DC [C]	Charge DC Bias for Cyan / 162 mm/s
92	CH DC [K]	Charge DC Bias for Black / 162 mm/s
93	CH AC [FC] L	Charger AC / Full Color / Low Speed
94	CH AC [K] L	Charger AC / Black / Low Speed
95	CH AC [FC] M	Charger AC / Full Color / Middle Speed
96	CH AC [K] M	Charger AC / Black / Middle Speed
97	CH AC [FC] H	Charger AC / Full Color / High Speed
98	CH AC [K] H	Charger AC / Black / High Speed
99	Dev DC [Y]	Development DC Bias for Yellow
100	Dev DC [M]	Development DC Bias for Magenta
101	Dev DC [C]	Development DC Bias for Cyan
102	Dev DC [K]	Development DC Bias for Black
103	Dev AC [FC] L	Development AC Bias for Color - Low Speed

SP5-804-XXX		Description
104	Dev AC [K] L	Development AC Bias for Black - Low Speed
105	Dev AC [FC] M	Development AC Bias for Color - Middle Speed
106	Dev AC [K] M	Development AC Bias for Black - Middle Speed
107	Dev AC [FC] H	Development AC Bias for Color - High Speed
108	Dev AC [K] H	Development AC Bias for Black - High Speed
109	Transfer [Y]	Transfer Current for Yellow
110	Transfer [M]	Transfer Current for Magenta
111	Transfer [C]	Transfer Current for Cyan
112	Transfer [K]	Transfer Current for Black
113	Cleaning Bias	Transfer Belt Cleaning Roller Bias
114	PA Roller Bias+	Paper Attraction Roller Bias
115	PA Roller Bias-	Paper Attraction Roller Bias
116	DevAC TRG [FC]	Development AC Trigger for Color
117	DevAC TRG [K]	Development AC Trigger for Black
118	DevPWM TRG [K]	Development PWM Trigger for Black
119	DevPWM TRG [C]	Development PWM Trigger for Cyan
120	DevPWM TRG [M]	Development PWM Trigger for Magenta
121	DevPWM TRG [Y]	Development PWM Trigger for Yellow
122	CHdcPWM TRG [K]	Charge DC PWM Trigger for Black
123	CHdcPWM TRG [C]	Charge DC PWM Trigger for Cyan
124	CHdcPWM TRG [M]	Charge DC PWM Trigger for Magenta
125	CHdcPWM TRG [Y]	Charge DC PWM Trigger for Yellow
126	CHac1 TRG [FC]	Charge AC1 Trigger for Color
127	Chac2 TRG [FC]	Charge AC2 Trigger for Color
128	Chac3 TRG [FC]	Charge AC3 Trigger for Color
129	CHac1 TRG [K]	Charge AC1 Trigger for Black
130	Chac2 TRG [K]	Charge AC2 Trigger for Black
131	Chac3 TRG [K]	Charge AC3 Trigger for Black
132	ID Sensor LED	ID Sensor LED
133	TD Vcnt	TD Sensor / Vcnt
134	Memory Chip	Memory Chip / Power (5V) Supply
136	PCU Cln Bias K	PCU Cleaning Bias for Black
137	PCU Cln Bias YMC	PCU Cleaning Bias for YMC
141	Polygon M L	Polygon Motor / 38,268 rpm
142	Polygon M H	Polygon Motor / 29,528 rpm
143	LD FC[K]: L	LD Power for Black in Color Mode / Low Speed
144	LD FC[K]: M	LD Power for Black in Color Mode / Middle Speed
145	LD FC[Y]: L	LD Power for Yellow in Color Mode / Low Speed
146	LD FC[Y]: M	LD Power for Yellow in Color Mode / Middle Speed
147	LD FC[M]: L	LD Power for Magenta in Color Mode / Low Speed
148	LD FC[M]: M	LD Power for Magenta in Color Mode / Middle Speed
149	LD FC[C]: L	LD Power for Cyan in Color Mode / Low Speed
150	LD FC[C]: M	LD Power for Cyan in Color Mode / Middle Speed
151	LD1 [K]: L	LD1 Power for Black / Low Speed
152	LD1 [K]: M	LD1 Power for Black / Middle Speed
153	LD1 [K]: H	LD1 Power for Black / High Speed
154	LD2 [K]: L	LD2 Power for Black / Low Speed

SP5-804-XXX		Description
155	LD2 [K]: M	LD2 Power for Black / Middle Speed
156	LD2 [K]: H	LD2 Power for Black / High Speed
157	LD [K]: L	LD Power for Black / Low Speed
158	LD [K]: M	LD Power for Black / Middle Speed
159	LD [K]: H	LD Power for Black / High Speed
165	PSU M	Optional Paper Feed Unit (PSU: Paper Supply Unit) / Motor
166	PF CL PSU (1)	Paper Feed Clutch / Optional Paper Feed Unit (PSU: Paper Supply Unit)/ Tray 1
167	PF CL PSU (2)	Paper Feed Clutch / Optional Paper Feed Unit (PSU: Paper Supply Unit)/ Tray 2
168	Pick-up SOL PSU	Pick-up Solenoid / Optional Paper Feed Unit (PSU: Paper Supply Unit)
170	MB M	4-bin Mailbox Main Motor
171	MB SOL1	4-bin Mailbox Junction Gate Solenoid 1
172	MB SOL2	4-bin Mailbox Junction Gate Solenoid 2
173	MB SOL3	4-bin Mailbox Junction Gate Solenoid 3
174	MB Gate SOL	4-bin Mailbox Junction Gate Solenoid
176	Duplex SOL	Duplex Junction Gate Solenoid
177	DI M1 81 CCW	Duplex Inverter Motor 1 / 81 / Counterclockwise
178	DI M1 65 CCW	Duplex Inverter Motor 1 / 65 / Counterclockwise
179	DI M1 125 CCW	Duplex Inverter Motor 1 / 125 / Counterclockwise
180	DI M1 162 CCW	Duplex Inverter Motor 1 / 162 / Counterclockwise
181	DI M1 185 CCW	Duplex Inverter Motor 1 / 185 / Counterclockwise
182	DI M1 193 CCW	Duplex Inverter Motor 1 / 193 / Counterclockwise
183	DI M1 230 CCW	Duplex Inverter Motor 1 / 230 / Counterclockwise
184	DI M1 370 CCW	Duplex Inverter Motor 1 / 370 / Counterclockwise
185	DI M1 370 CW	Duplex Inverter Motor 1 / 370 / Clockwise
186	DI M1 450 CW	Duplex Inverter Motor 1 / 450 / Clockwise
187	DI M1 81 CCW	Duplex Inverter Motor 1 / 81 / Counterclockwise
188	DI M2 62.5 CCW	Duplex Inverter Motor 2 / 62.5 / Counterclockwise
189	DI M2 65 CCW	Duplex Inverter Motor 2 / 65 / Counterclockwise
190	DI M2 125 CCW	Duplex Inverter Motor 2 / 125 / Counterclockwise
191	DI M2 162 CCW	Duplex Inverter Motor 2 / 162 / Counterclockwise
192	DI M2 185 CCW	Duplex Inverter Motor 2 / 185 / Counterclockwise
193	DI M2 193 CCW	Duplex Inverter Motor 2 / 193 / Counterclockwise
194	DI M2 230 CCW	Duplex Inverter Motor 2 / 230 / Counterclockwise
195	DI M2 370 CCW	Duplex Inverter Motor 2 / 370 / Counterclockwise
196	DI M2 370 CW	Duplex Inverter Motor 2 / 370 / Clockwise
197	DI M2 450 CW	Duplex Inverter Motor 2 / 450 / Clockwise
198	DI M2 81 CCW	Duplex Inverter Motor 2 / 81 / Counterclockwise
199	DI M2 OFF	Duplex Inverter Motor 2 / OFF
200	DI M12 62.5 CCW	Duplex Inverter Motor 1&2 / 62.5 / Counterclockwise
201	DI M12 65 CCW	Duplex Inverter Motor 1&2 / 65 / Counterclockwise
202	DI M12 125 CCW	Duplex Inverter Motor 1&2 / 125 / Counterclockwise
203	DI M12 162 CW	Duplex Inverter Motor 1&2 / 162 / Clockwise
204	DI M12 185 CW	Duplex Inverter Motor 1&2 / 185 / Clockwise
205	DI M12 193 CCW	Duplex Inverter Motor 1&2 / 193 / Counterclockwise

SP5- 804-XXX		Description
206	DI M12 230 CCW	Duplex Inverter Motor 1&2 / 230 / Counterclockwise
207	DI M12 370 CCW	Duplex Inverter Motor 1&2 / 370 / Counterclockwise
208	DI M12 370 CW	Duplex Inverter Motor 1&2 / 370 / Clockwise
209	DI M12 450 CW	Duplex Inverter Motor 1&2 / 450 / Clockwise
210	DI M12 81 CCW	Duplex Inverter Motor 1&2 / 81 / Counterclockwise
211	PF M 125	Paper Feed Motor / 125 mm/s
212	PF M 162	Paper Feed Motor / 162 mm/s
213	PF M 185	Paper Feed Motor / 185 mm/s
214	PF M 230	Paper Feed Motor / 230 mm/s
215	PF M 370	Paper Feed Motor / 370 mm/s
216	PF M 81	Paper Feed Motor / 81 mm/s

5.3.5 TEST PATTERN (SP5-997)

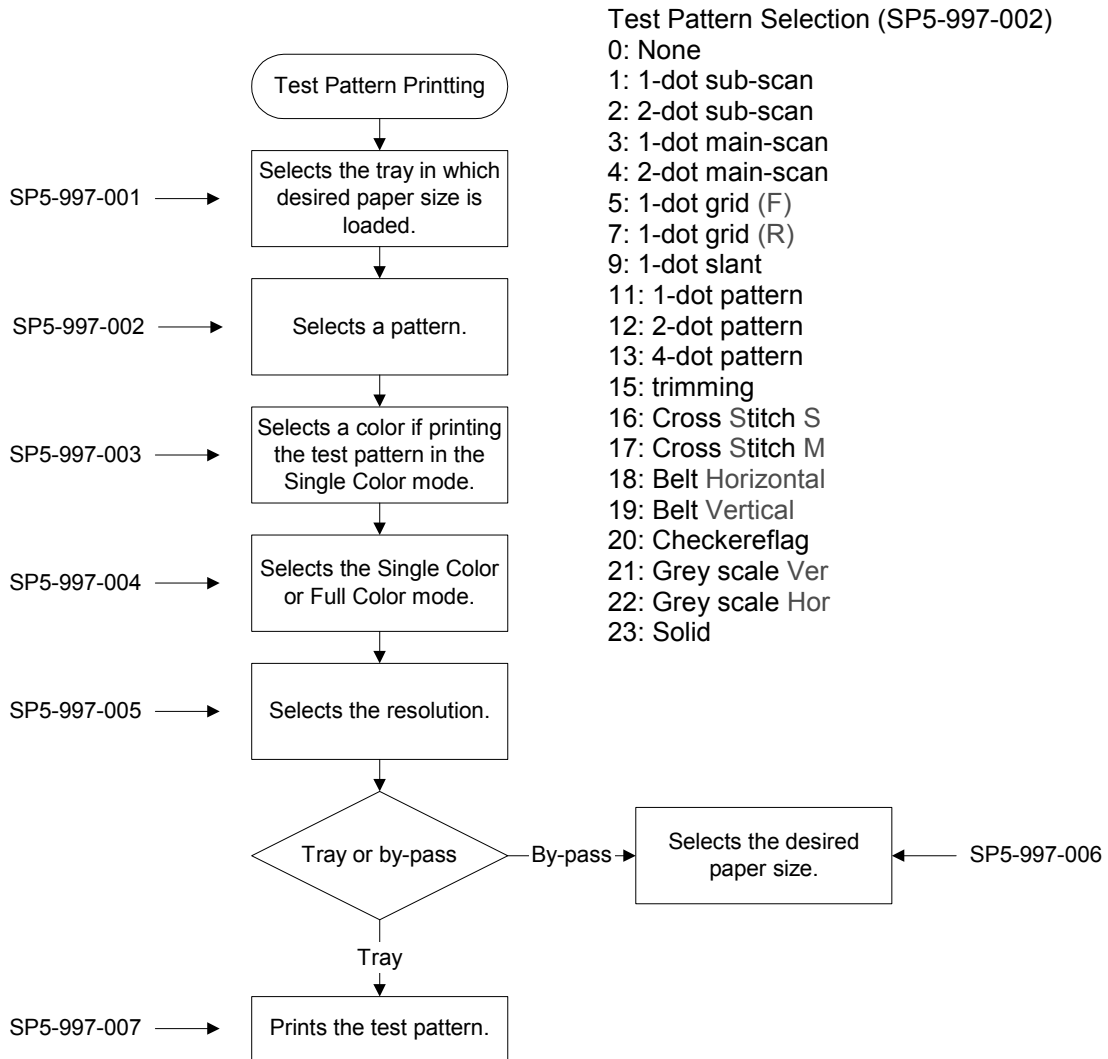

G130S502.WMF



5.4 FIRMWARE UPDATE

5.4.1 TYPE OF FIRMWARE

The table lists the programs used by this machine.

Type of firmware	Function	Location of firmware	Message displayed
Engine - Main	Printer engine control	BCU flash ROM	Engine
Engine - MUSIC	Line position adjustment	BCU MUSIC CPU	Music
System	Printer system management	SD card	system
Printer Application	Feature application	SD card	Opt SD1 Prn
NIB	NIB management	SD card	Network Support
Web System	Web service application	SD card	Web Support
Netfile	Netfile Application	SD card	Network DocBox

5.4.2 PRECAUTIONS

Handling SD Cards

Observe the following precautions when handling SD cards:

- Turn off the main power switch before you insert or remove an SD card. Data in the SD card can be corrupted if you insert or remove an SD card while the main power switch is on.
- Do not turn off the main power switch during downloading.
- Keep SD cards in a safe location. Do not store SD cards in these locations:
 - Locations exposed to high temperature, high humidity, direct sunlight, or strong vibration
 - Locations where there are effects from magnetic forces
- Do not bend or scratch SD cards.
- Do not drop SD cards or expose them to shock or vibration.

NOTE: For the arrangement of files in SD cards, see 5.4.3.

Upload or Download

In this section (5.4), 'upload' and 'download' have these meanings:

- Upload: To copy data from the printer to the SD card
- Download: To copy data from the SD card to the printer

Network Connection

Before you start, tell the user that they cannot use the printer during firmware update, and that they must disconnect the printer physically from the network. If a print job comes in, this can cause problems with the firmware update.

5.4.3 FILE ARRANGEMENT

How the Program Works

The firmware-update program for this machine searches the folder *romdata* for necessary firmware. When you save the firmware in a SD card, make the folder *romdata*. You must not make the folder *romdata* in another folder; but you can make more than one folder in the folder *romdata*. The firmware-update program searches all folders if they are in *romdata*.

Each firmware program contains the file information. Before downloading the firmware from an SD card, the firmware-update program reads the file information. The firmware is downloaded only when the file information is correct.

NOTE: The file information can identify the firmware, but this information does not guarantee that the data is not corrupted.

Example

When you save the firmware, we recommend that you arrange folders and files as follows:

- In the folder *romdata*, make another folder and use this folder exclusively for one model. Use the machine code as the name of this folder.
- When you save the firmware of a different model, make a new folder in the folder *romdata*. Give it a name as mentioned above. (The diagram shows an example. The folder *romdata* has three sub-folders: B130, B149, and G131. Each folder is for one model.)
- When you save some files other than firmware, make a new folder outside *romdata*. Save the files in this folder. Do not save any file outside the folders. (The diagram shows an example. Three folders, *log*, *nvrामdata*, and *prt*, are outside *romdata*. These folders can store debug logs, NVRAM data, and captured files respectively.)

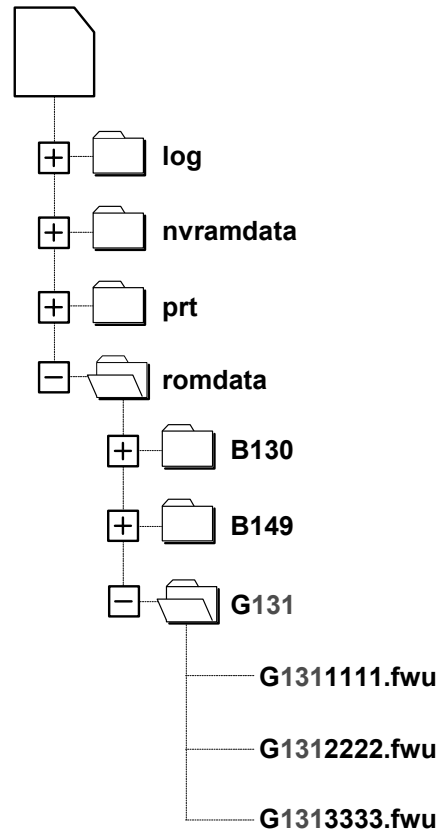

Service Tables

G130S503.WMF

5.4.4 UPDATING

Procedure

1. Turn off the main power switch.
2. Disconnect the printer from the network (☛ 5.4.2).
3. Remove the slot cover [A] (⚙ x 1).
4. Turn the label face of the SD card to the front side of the printer, and insert it into slot 3 [B].
5. Slowly push the SD card into the slot until it clicks.
6. Make sure that the SD card is locked in place.

NOTE: To remove the SD card, push it in until it clicks, and release it slowly. The slot pushes out the SD card.

7. Turn on the main power switch.
8. Wait until a firmware name is shown on the display (about 45 seconds).

NOTE: The firmware name is read from inside the firmware. The firmware name is not changed even if you change the file name on your PC.
9. If the necessary firmware name is shown on the display, go to the next step. To use a different firmware, push the up-arrow key or the down-arrow key to find the necessary firmware.
10. To confirm the firmware version, press the menu key twice after the firmware name shows. This ensures that you have updated the correct firmware version.
11. To select the firmware, push the enter key. Make sure that a star (*) is added to the firmware name.
12. If you update more than one firmware program at the same time, find each of them and select each of them. Make sure a star is added to each firmware name.
13. To select "Update Data", push the up-arrow key or the down-arrow key.

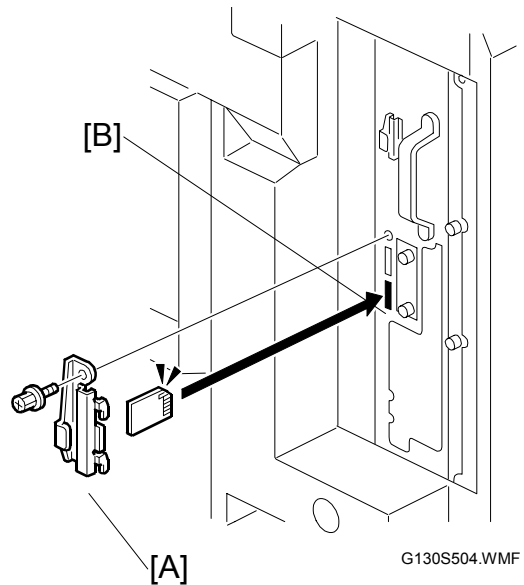

14. To start firmware update, push the enter key. While each firmware is downloaded, the underscores on the operation panel are replaced by stars.
15. Wait until the message “Updated” is shown.
16. Turn off the main power switch.
17. Remove the SD card from the slot.
18. Attach the slot cover (🔑 x 1).
19. Connect the printer to the network physically.
20. Turn on the main power switch.
21. Print the Configuration Page to check that the every firmware is correctly updated: Menu > List/Test Print > Config.P/Er.Log

Error Handling

An error code is shown if an error occurs during the download. Error codes have the letter “E” and a number. If an error occurs, the firmware is not correctly downloaded; see the error code table (5.4.6) and do the necessary steps. After this, download the firmware again.

Power Failure

If firmware update is interrupted by power failure, the firmware is not correctly downloaded. In this condition, machine operation is not guaranteed. You have to download the firmware again.

5.4.5 NVRAM DATA UPLOAD/DOWNLOAD

CAUTION

Turn off the main power switch before you insert or remove an SD card. Make sure that the controller and the BCU are correctly connected.

Uploading NVRAM Data

Copy the data from the NVRAM to an SD card (referred to as “to upload NVRAM data” in this section) before you replace the NVRAM. If you cannot upload NVRAM data, manually input the necessary settings after you replace the NVRAM.

1. Start the SP mode.
2. Select SP5-990-001 (ALL (Data List)).
3. Do the SP.
4. See if the SMC Report is correctly output.
NOTE: You may need the SMC Report when the machine did not complete an NVRAM data upload or download (☛ Downloading NVRAM Data) correctly.
5. Go out of the SP mode.
6. Turn off the main power switch.
7. Insert an SD card into slot 3.
8. Turn on the main power switch.
9. Start the SP mode.
10. Select SP5-824 (NVRAM Upload).
11. Push the enter key. The upload starts.
When uploading ends correctly, the following file is made:
NVRAM\serial_number.NV
where “NVRAM” is the folder name in the SD card and “serial_number.NV” is the file name with the extension “.NV”. The serial number of the printer is used as the file name. For example, if the serial number is G1310017, the file name is “G1310017.NV”.
12. Go out of the SP mode.
13. Turn off the main power switch.
14. Remove the SD card.
15. Mark the SD card with, for example, the machine code. You need this SD card when you download NVRAM data (☛ Downloading NVRAM Data).
NOTE: One SD card can store the NVRAM data from two or more machines.

Downloading NVRAM Data

Copy the data from the SD card to the NVRAM (referred to as “to download NVRAM data” in this section) after you replace the NVRAM. If you cannot download NVRAM data, manually input the necessary settings.

1. Make sure that the main power switch is off. If it is on, turn it off.
2. Make sure that you have the correct SD card that contains the necessary NVRAM data.
3. Insert the SD card into slot 3.
4. Turn on the main power switch.
5. Start the SP mode.
6. Select SP5-825 (NVRAM Download).
7. Push the enter key. The download starts.

NOTE: The machine cannot do the download if the file name in the SD card is different from the serial number of the printer (●Uploading NVRAM Data).

8. Go out of the SP mode.
 9. Turn off the main power switch.
 10. Remove the SD card.
 11. Turn on the main power switch.
 12. Check that the NVRAM data is correctly downloaded.
- This procedure does not download the following data to the NVRAM:

- Total Count
- Machine's Device Number

5.4.6 ERROR CODE TABLE

These error codes are used by more than one model. Some codes are not used by this machine.

Code	Cause	Solution
20	Cannot map logical address	Make sure SD card inserted correctly, or use another SD card.
21	Cannot access memory	HDD connection incorrect or replace hard disks.
22	Cannot decompress compressed data	Incorrect ROM data on the SD card, or data is corrupted.
23	Error occurred when ROM update program started	Controller program abnormal. If the second attempt fails, replace controller board.
24	SD card access error	Make sure SD card inserted correctly, or use another SD card.
30	No HDD available for stamp data download	HDD connection incorrect or replace hard disks.
31	Data incorrect for continuous download	Insert the SD card with the remaining data required for the download, the re-start the procedure.
32	Data incorrect after download interrupted	Execute the recovery procedure for the intended module download, then repeat the installation procedure.
33	Incorrect SD card version	Incorrect ROM data on the SD card, or data is corrupted.
34	Module mismatch - Correct module is not on the SD card)	SD update data is incorrect. Acquire the correct data (Japan, Overseas, OEM, etc.) then install again.
35	Module mismatch – Module on SD card is not for this machine	SD update data is incorrect. The data on the SD card is for another machine. Acquire correct update data then install again.
36	Cannot write module – Cause other than E34, E35	SD update data is incorrect. The data on the SD card is for another machine. Acquire correct update data then install again.
40	Engine module download failed	Replace the update data for the module on the SD card and try again, or replace the BCU board.
42	Operation panel module download failed	Replace the update data for the module on the SD card and try again, or replace the LCDC.
43	Stamp data module download failed	Replace the update data for the module on the SD card and try again, or replace the hard disks.
44	Controller module download failed	Replace the update data for the module on the SD card and tray again, or replace controller board.
50	Electronic confirmation check failed	SD update data is incorrect. The data on the SD card is for another machine. Acquire correct update data then install again.

5.5 SD CARD APPLI MOVE

5.5.1 OVERVIEW

The service program “SD Card Appli Move” (SP5-873) enables you to copy application programs from an SD card to another SD card.

There are three SD card slots. This machine uses slot 1 to store the firmware of this machine and application programs. Slot 2 is for storing application programs. Slot 3 is for maintenance work only. Because of this, if the application programs are stored in three SD cards or more, ① choose one SD card or two from these SD cards and ② store all the application programs on these one or two cards.

Use extreme caution when using SD Card Appli Move:

1. The authentication data is transferred with the application program from an SD card to the other SD card. Authentication fails if you try to use the SD card after you copy the application program from this card to another SD card.
2. Do not use an SD card if it has been used for some other work, for example, on a computer. Normal operation is not guaranteed when such SD card is used.
3. Keep the SD card in a safe place after you copy the application program from the card to another card. This is because: ① The SD card can be the only proof that the user is licensed to use the application program. ② You may need to check the SD card and its data to solve a problem in the future.
4. You cannot copy PostScript data to another SD card. You can copy an application program to the SD card that stores PostScript data.

5.5.2 MOVE EXEC

The menu "Move Exec" (SP5-873-001) enables you to copy application programs from the original SD card to another SD card. The application programs are copied as follows:

- From slot 3 to slot 1 when SD cards are in slots 1 and 3

Note that the authentication data is also copied with the application program (see 5.5.1).

1. Turn off the main power switch.
2. Make sure that an SD card is in slot 1. The application program is copied to this SD card.
3. Insert the SD card (having stored the application program) to slot 3. The application program is copied from this SD card.
4. Turn on the main power switch.
5. Start the SP mode.
6. Select SP5-873-001 "Move Exec."
7. Follow the messages displayed on the operation panel.
8. Go out of the SP mode.
9. Turn off the main power switch.
10. Remove the SD card from slot 3.
11. Turn on the main power switch.
12. Check that the application programs run normally.

5.5.3 UNDO EXEC

The menu “Undo Exec” (SP5-873-002) enables you to copy back application programs from an SD card to the original SD card. You can use this program when, for example, you have mistakenly copied some programs by using Move Exec (SP5-873-001). The application programs are copied as follows:

- From slot 2 to slot 3 when SD cards are in slots 2 and 3 or in all slots
- From slot 1 to slot 3 when SD cards are in slots 1 and 3

Note that the authentication data is also copied with the application program (☛ 5.5.1).

1. Turn off the main power switch.
2. Insert the original SD card in slot 3. The application program is copied back to this card.
3. Insert the SD card (having stored the application program) to slot 1 or 2. The application program is copied back from one of these SD cards.
4. Turn on the main power switch.
5. Start the SP mode.
6. Select SP5-873-002 “Undo Exec.”
7. Follow the messages displayed on the operation panel.
8. Go out of the SP mode.
9. Turn off the main power switch.
10. Remove the SD card from slot 3.
11. Turn on the main power switch.
12. Check that the machine operates correctly.

5.6 CONTROLLER SELF-DIAGNOSTICS

5.6.1 OVERVIEW

There are three types of self-diagnostics for the controller.

- Power-on self-diagnostics: The machine automatically starts the self-diagnostics just after the power has been turned on.
- Detailed self-diagnostics: The machine does the detailed self-diagnostics by using a loop-back connector (P/N G0219350)
- SC detection: The machine automatically detects SC conditions at power-on or during operation.

The following shows the workflow of the power-on and detailed self-diagnostics.

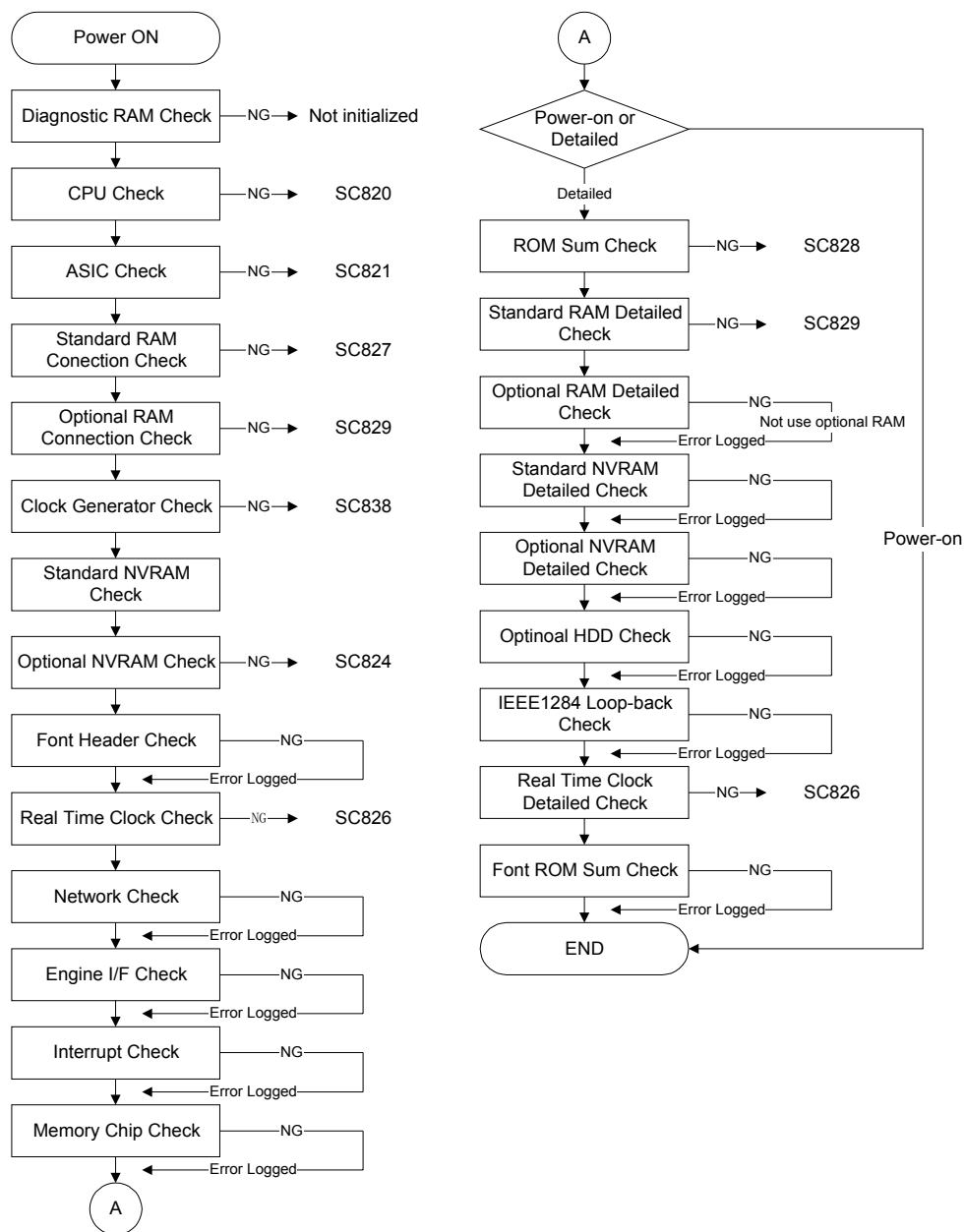

G130S505.WMF

5.6.2 DETAILED SELF-DIAGNOSTICS

This detailed self-diagnostic test requires a loop-back connector (P/N: G0219350).

1. Turn off the machine and attach the loop-back connector to the parallel interface.
2. Turn on the machine while pressing the “On Line” key and “# Enter” key together.
3. The machine automatically starts the self-diagnostics and prints the diagnostic report after completing the test.
 - Refer to the diagnostics report for the detected errors. The errors detected during self-diagnostics can be checked with SP7-832-001 (Diag. Result).
 - Refer to section 4.1 for details about the error codes.

5.7 USER PROGRAM MODE

To enter a User Program

1. Push the menu key to start the user program mode.
2. Use the up arrow key and the down arrow key to select a program.
3. Push the enter key to start the program.

NOTE: To return to step 1, press the escape key one or more times.

To exit a User Program

Push the online key or push the escape key one or more times until “ready” is shown.

Menu List

For more, print the menu list (Menu > List/Test Print > Menu List).

Sample Print

- Print One File
- Print All Files
- Delete One File
- Del. All Files
- Error File(s)

Locked Print

- Print One File
- Print All Files
- Delete One File
- Del. All Files
- Error File(s)

Hold Print

- Print One File
- Print All Files
- Delete One File
- Del. All Files
- Error File(s)

Stored Print

- Print One File
- Print All Files
- Delete One File
- Del. All Files
- Error File(s)

Paper Input

- Bypass Size
- Tray Paper Size
- Paper Type
- Aut. Tray Select
- Tray Priority

List/Test Print

- Config. Page/Error Log
- Config. Page
- Error Log
- Menu List
- Color Demo Page
- PCL Config. Page
- PS Config. Page
- PDF Config. Page
- Hex Dump
- Operations Test

Maintenance

- Color Registration
- Color Calibrate
- Image Density
- Registration
- Plain Paper
- Thick Paper
- Special Paper
- Del. All Temp
- Del. All Stored
- HD format
- 4C. Graphic Mode
- Fuser Temperature.
- Replacement Alert
- Date/ Time
- Key Repeat
- Erase All Mem.

System

- Print Error Report
- Auto Continue
- Memory Overflow
- Copies
- Printer Language
- Sub Paper Size
- Page Size
- Edge-Edge Print
- Def. Printer Language
- Duplex
- Blank Page
- Output Tray
- Energy Saver 1
- Energy Saver 2
- Auto Reset Time
- Auto Del. Temp
- Auto Del. Stored
- Unit of Measure
- B&W Page Detect
- Spool Printing
- Letterhead Mode
- Bypass Priority
- Tray Switching
- Notify by Email

Host Interface

- I/O Buffer
- I/O Timeout
- Network Setup

PCL Menu

- Orientation
- Form Lines
- Font Source
- Font Number
- Point Size
- Font Pitch
- Symbol Set
- Courier Font
- Ext. A4 Width
- Append CR to LF
- Resolution

PS Menu

- Data Format
- Resolution
- Color Setting
- Color Profile

PDF Menu

- PDF: Change PW
- PDF Group PW
- Resolution
- Color Setting
- Color Profile

Language

5.8 DIP SWITCHES

Controller Board

All switches are off.

BCU Board

Locale	DIP Switch				
	1	2	3	4	
				G130	G131
North America	On	Off	Off	Off	On
Europe	Off	On	Off	Off	On
Asia	On	On	Off	Off	On

6. DETAILED SECTION DESCRIPTIONS

6.1 OVERVIEW

6.1.1 COMPONENT LAYOUT

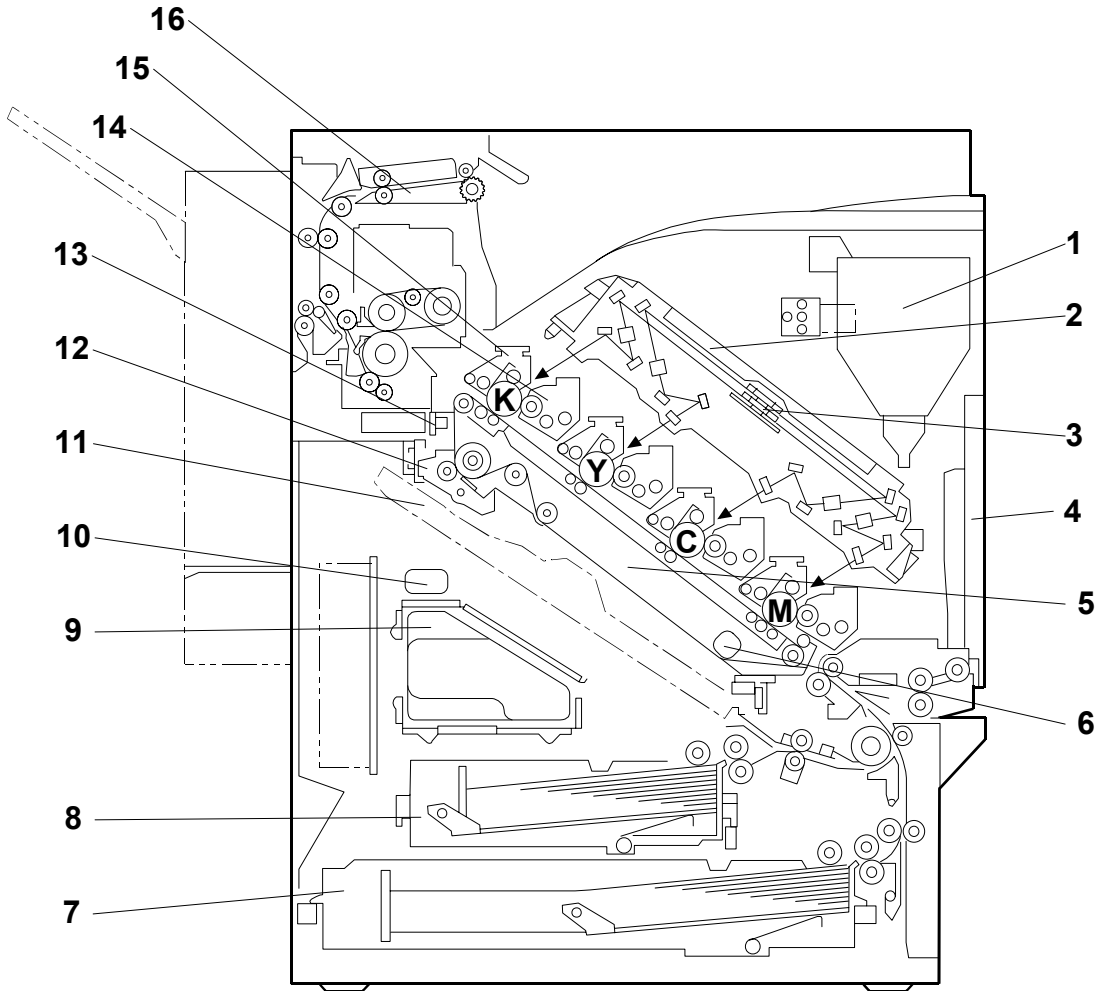

G130D501.WMF

- | | |
|------------------------------|-----------------------------------|
| 1. Toner cartridge | 9. Waste toner bottle |
| 2. Laser optics housing unit | 10. Waste toner vibrator |
| 3. Polygon mirror motor | 11. Duplex feed unit |
| 4. By-pass feed table | 12. Transfer belt cleaning unit |
| 5. Transfer unit | 13. ID sensor |
| 6. Rotation encoder | 14. Development unit (each color) |
| 7. Tray 2 | 15. PCU (each color) |
| 8. Tray 1 | 16. Fusing unit |

6.1.2 PAPER PATH

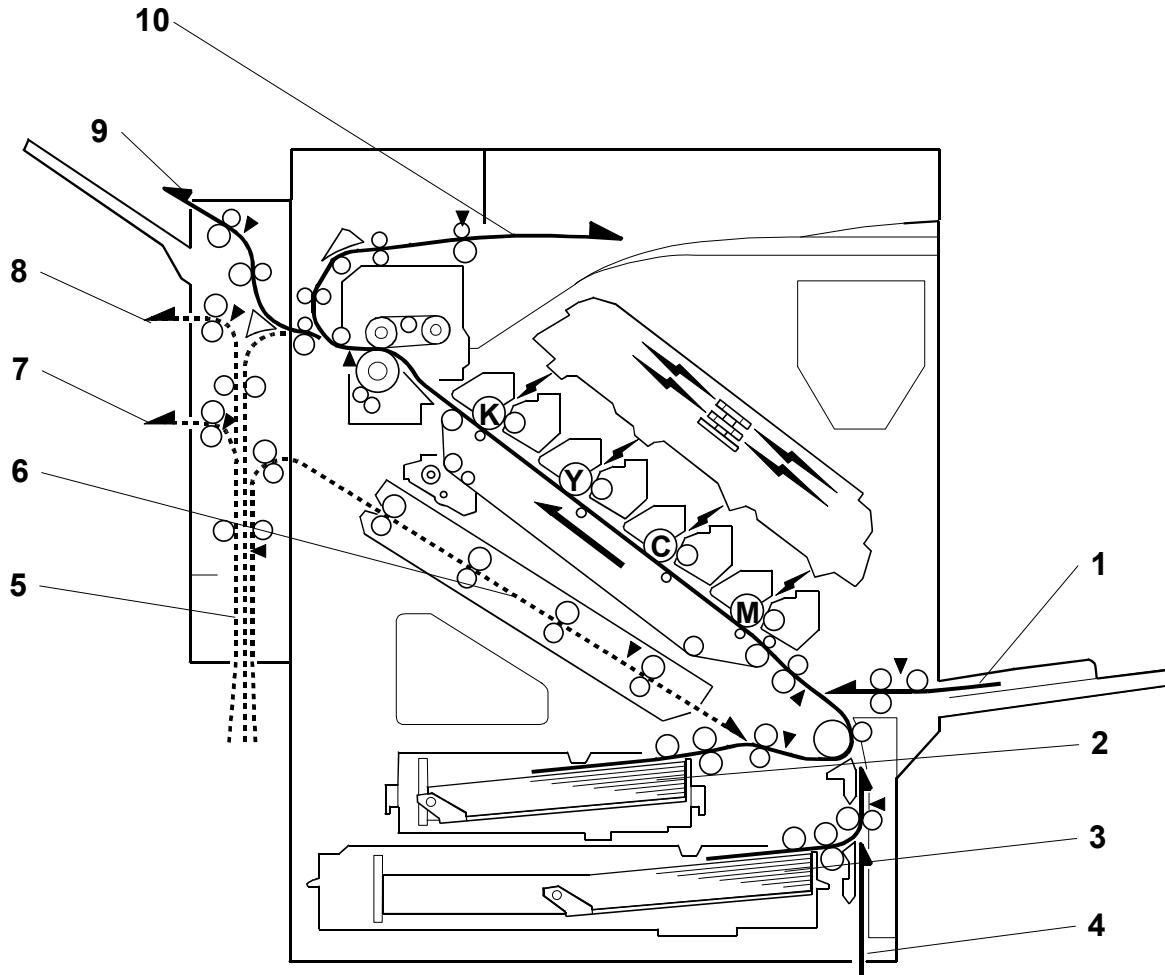

G130D502.WMF

- | | |
|---------------------------------|-------------------------|
| 1. By-pass tray | 6. Duplex feed unit |
| 2. Tray 1 | 7. To optional finisher |
| 3. Tray 2 | 8. To optional finisher |
| 4. Optional paper feed unit/LCT | 9. External Tray |
| 5. Duplex inverter unit | 10. Standard tray |

The two-tray finisher requires an optional paper feed unit or the LCT. The duplex inverter unit has two exits for the two-tray finisher. When the one-tray paper feed unit is installed, paper feeds out to the two-tray finisher from the upper exit [8]. When the two-tray paper feed unit or LCT is installed, paper feeds out to the two-tray finisher from the lower exit [7]. Paper always feeds out to the booklet finisher from the lower exit [7] regardless of which optional paper feed unit (one-tray paper feed unit, two-tray paper feed unit or the LCT) is installed.

6.1.3 DRIVE LAYOUT

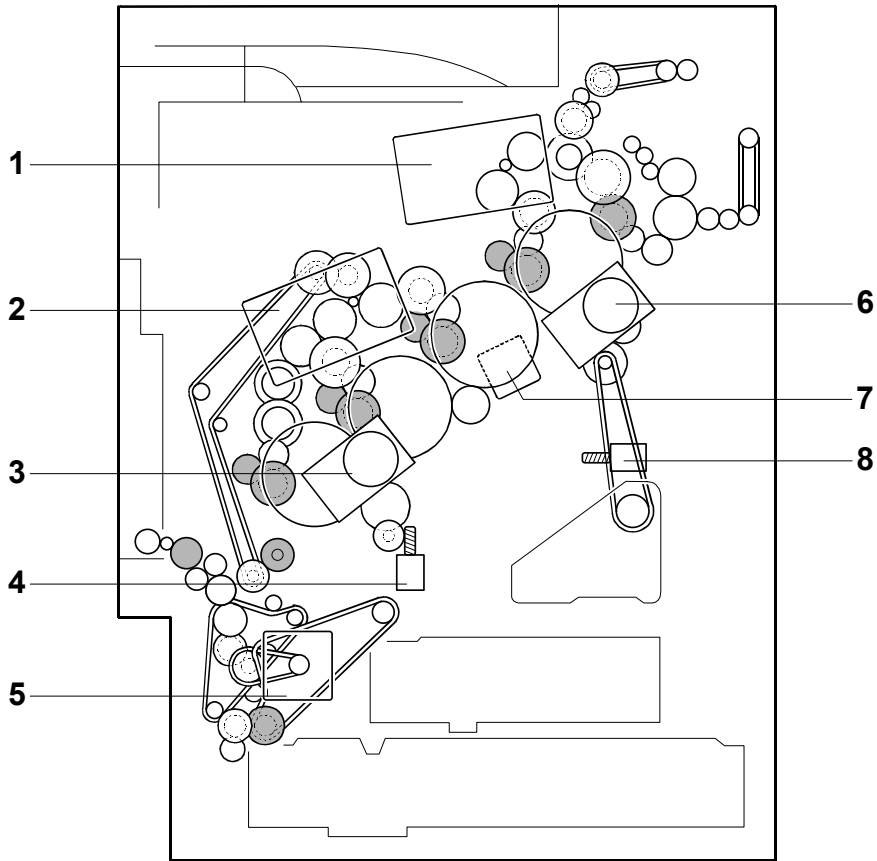

G130D503.WMF

- | | |
|---------------------------------|--|
| 1. Development drive motor-K: | Drives the development unit for black, the fusing unit, and the paper exit section. |
| 2. Development drive motor-CMY: | Drives the color development units (magenta/cyan/yellow), the registration roller, and the waste toner collection coils from the PCUs. |
| 3. Drum drive motor-CMY: | Drives the PCUs for magenta, cyan, and yellow. |
| 4. Transfer belt contact motor: | Moves the transfer belt into contact and away from the color PCUs. |
| 5. Paper feed motor: | Drives the paper feed mechanisms (tray 1/tray 2/by-pass tray). |
| 6. Drum drive motor-K: | Drives the black PCU and the collection coil in the waste toner bottle. |
| 7. Transfer unit drive motor: | Drives the transfer unit. |
| 8. Waste toner vibration motor: | Makes vibrations to not let waste toner clog the waste toner path. |

Detailed Descriptions

6.1.4 BOARD STRUCTURE

Overview

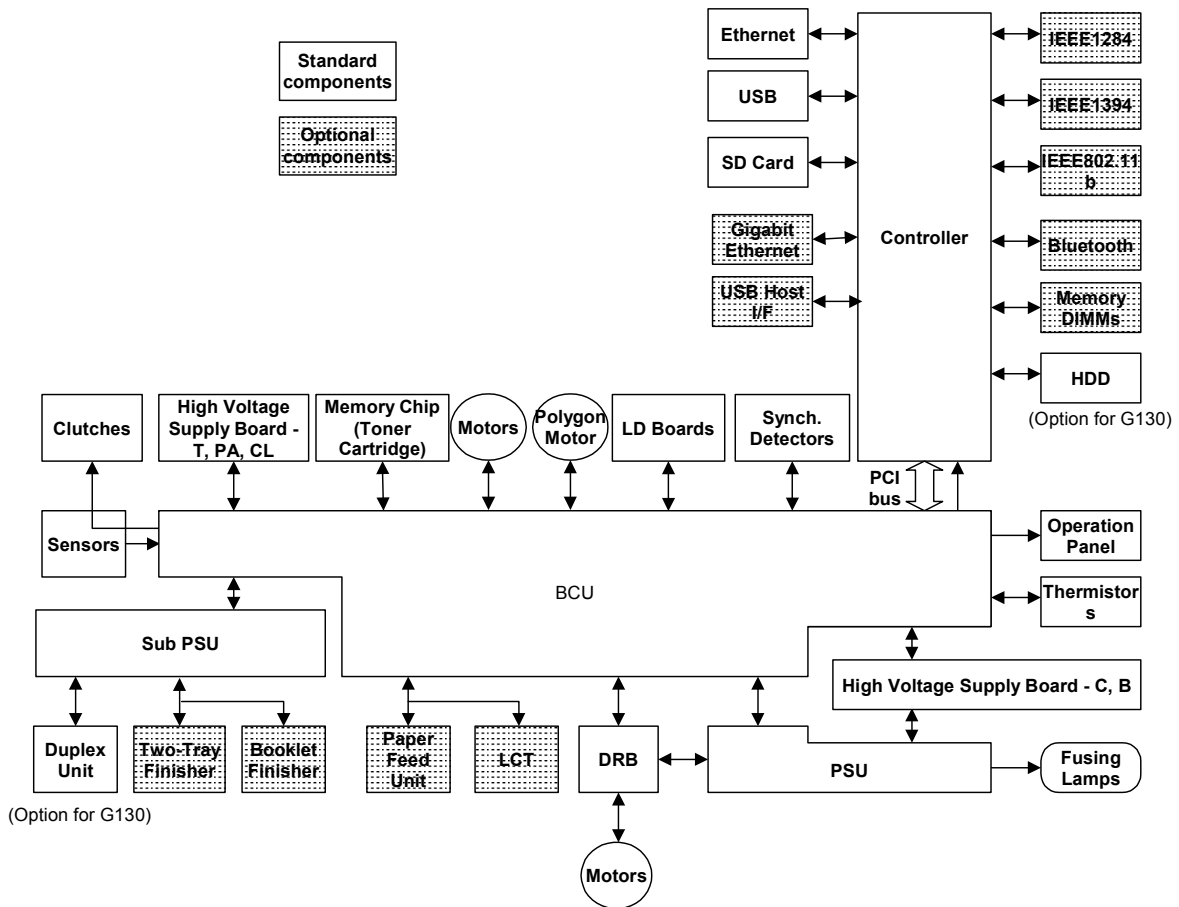

G130D504.WMF

Descriptions

BCU (Base Engine Control Unit):

The BCU controls all the mechanical components. The BCU has three CPUs (Main, MUSIC, and DSP). The CPUs control the following functions:

Main CPU

- Engine sequence
- Engine operation
- Timing for peripherals
- High voltage supply, laser, and fusing
- Sensors, drive board, and solenoids
- Motors

MUSIC (Mirror Unit for Skew and Interval Correction) CPU

- TD sensor
- Line position adjustment
- Memory chip on the toner cartridge

DSP (Digital Signal Processor)

- Line position adjustment

Controller:

The controller connects to the BCU through a PCI bus. The controller handles the following functions:

- Machine-to-host interface
- Operation panel interface
- Network interface
- Interfacing and control of the optional IEEE1284, Bluetooth, IEEE1394, IEEE802.11b (wireless LAN), Gigabit Ethernet, USB Host I/F, HDD, and DRAM DIMM

LD Drive Board:

This is the laser diode drive circuit board.

DRB:

The DRB (driver board) controls the paper feed motor, development motors (color/black), drum drive motors (color/black), transfer unit drive motor.

Operation Panel Board:

Controls the display panel, the LED and the keypad.

6.1.5 PRINTING PROCESS

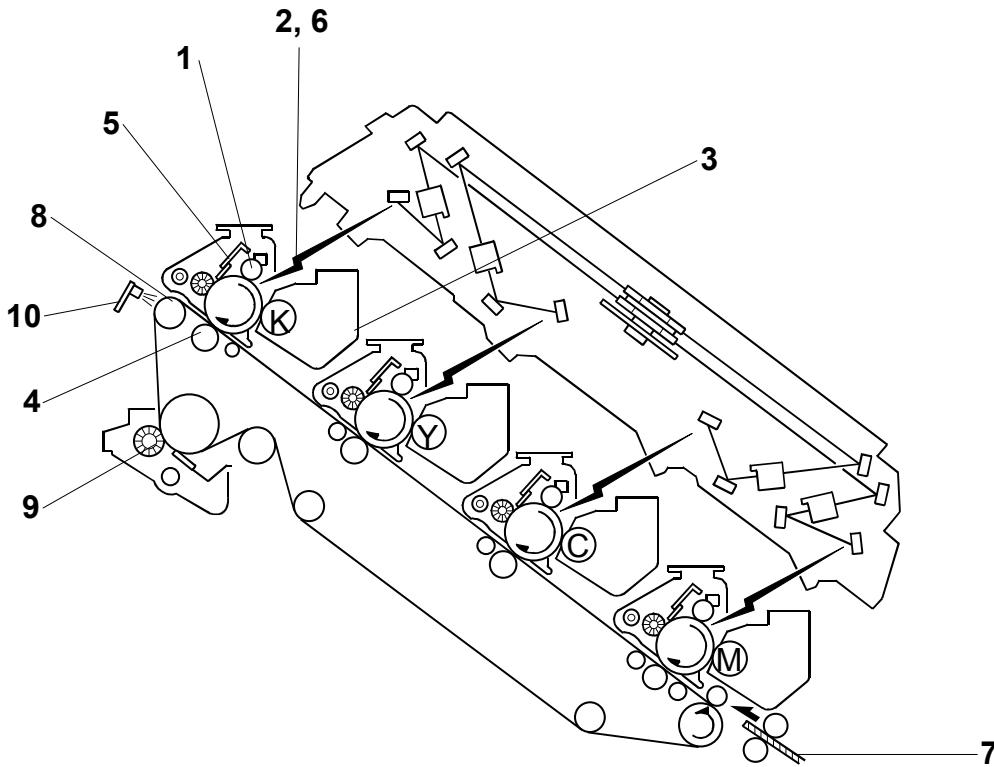

G130D505.WMF

This machine uses four PCUs, four development units, and four laser beams for color printing. Each PCU has a drum, charge roller, cleaning brush, and blade. From the left, the PCU stations are black, yellow, cyan, and magenta.

A transfer belt feeds paper past the PCUs. Then the toner image on each drum is transferred to the paper.

The paper path is inclined at about 38 degrees. This helps to keep the machine as compact as possible.

1. **Drum charge:**
The charge roller gives the drum a negative charge
2. **Laser exposure:**
The laser beam from the laser diode (LD) goes through the lens and mirrors and reaches the drum. The machine turns the laser beam on and off to make a latent image on the drum.
3. **Development:**
The development roller carries negatively charged toner to the latent image on the drum surface. This machine uses four independent development units (one for each color).
4. **Image transfer:**
The charge given to the transfer roller attracts the toner from the drum to the paper. Four toner images are super-imposed onto the paper.
5. **Cleaning for OPC drum:**
The cleaning brush and blade remove remaining toner on the drum surface after image transfer to the paper.
6. **Quenching for OPC drum:**
Quenching is done by illuminating the whole area of the drum with the laser at the end of every job.
7. **Paper attraction:**
Paper is attracted to the transfer belt by the charge given to the paper attraction roller.
8. **Separation:**
Paper separates from the transfer belt when the belt curves away from it.
9. **Cleaning and quenching for transfer belt:**
The cleaning brush and blade clean the belt surface. The grounding roller inside the transfer belt unit removes the remaining charge on the belt.
10. **ID sensor:**
The ID sensor board contains three ID sensors (front, center, and rear). The ID sensor detects the density of the ID sensor pattern on the transfer belt. The ID sensor output is used for the following:
 - Process control and for automatic line position
 - Skew
 - Color registration adjustments for the latent image.

6.2 PROCESS CONTROL

6.2.1 OVERVIEW

This machine has the following two forms of process control:

- Potential control
- Toner supply control

The process control facilities of this machine have the following features:

- Three ID (image density) sensors (front, center, and rear). Only the center ID sensor is used for process control. All ID sensors are used for line positioning and other adjustments.
- TD sensor.

6.2.2 POTENTIAL CONTROL

Overview

Potential control controls development to maintain the density of the toner images on the drums. It does this by compensating for variations in drum chargeability and toner density.

The machine uses the center ID sensor to measure the reflectivity of the transfer belt and the density of a standard sensor pattern. This is done during the process control self check.

The machine determines the following depending on the ID sensor output and a reference table in memory.

- VD: Drum potential without exposure. The machine adjusts the charge roller voltage to adjust this.
- VB: Development bias
- VL: Drum potential at the strongest exposure. The machine adjusts the laser power to adjust this.

(In addition, VREF is corrected. This is used for toner supply control.)

This process controls the development potential so that the maximum amount of toner given to the drum is constant. However, the laser power control method can be changed to control the development potential to improve reproduction of highlight parts of images. This depends on the setting of SP3-125-2. The default setting is "Process Control". Set this SP mode to "LD Power" if you want to change the highlight range control method.

If SP3-125-1 is set to "OFF", the machine does not do the potential control. Instead, the machine uses the following:

- Development bias adjusted with SP2-201-1 to -9
- Charge roller voltage adjusted with SP2-001-1 to -13
- Laser power selected with SP2-103-1 to -15.

You should not adjust these SP modes in the field.

Process Control Self Check

This machine uses the process control self check method to do the potential control. The machine uses seven types of process control self check. These are categorized according to their execution timing:

1. **Forced**
This is done when SP3-126-1 is used.
2. **Initial**
This starts automatically when the power is turned on, or, when the machine recovers from energy saver mode (you can change this with SP3-125-7). This occurs only if the fusing unit pressure roller temperature is 60°C or less.
3. **Interval: Job End**
This starts automatically at the end of a print job when the total print counter for this feature exceeds 200 (you can change this with SP3-906-1). The counters are reset to '0' after all process control is done (except for forced process control).
4. **Interval: Interrupt (default: not done)**
This interrupts printing and then starts automatically at the following times:
 - 1) When the machine makes a certain number (A) of continuous color prints in the same job
 - 2) The main scan length detection is executed.After the above are completed, the machine continues to make prints.
You can adjust value A with SP3-906-2 (default: off). At this time, only VREF is corrected. Potential control (VD, VB, VL correction) is not done.
5. **Non-use Time (default: not done)**
This starts before the next print job if the machine has no job for a certain time (M) after it makes more than a certain number (N) of prints.
You can adjust M with SP3-906-4. You can adjust N with SP3-906-3.
6. **After Toner End Recovery**
This starts after recovery from a toner end condition.
7. **After Developer Initialization**
The machine executes the Auto Toner Density Adjustment (SP3-125-003). This starts after a developer initialization is done. Developer initialization occurs automatically after a new development unit has been installed.

6.2.3 PROCESS CONTROL SELF CHECK PROCEDURE

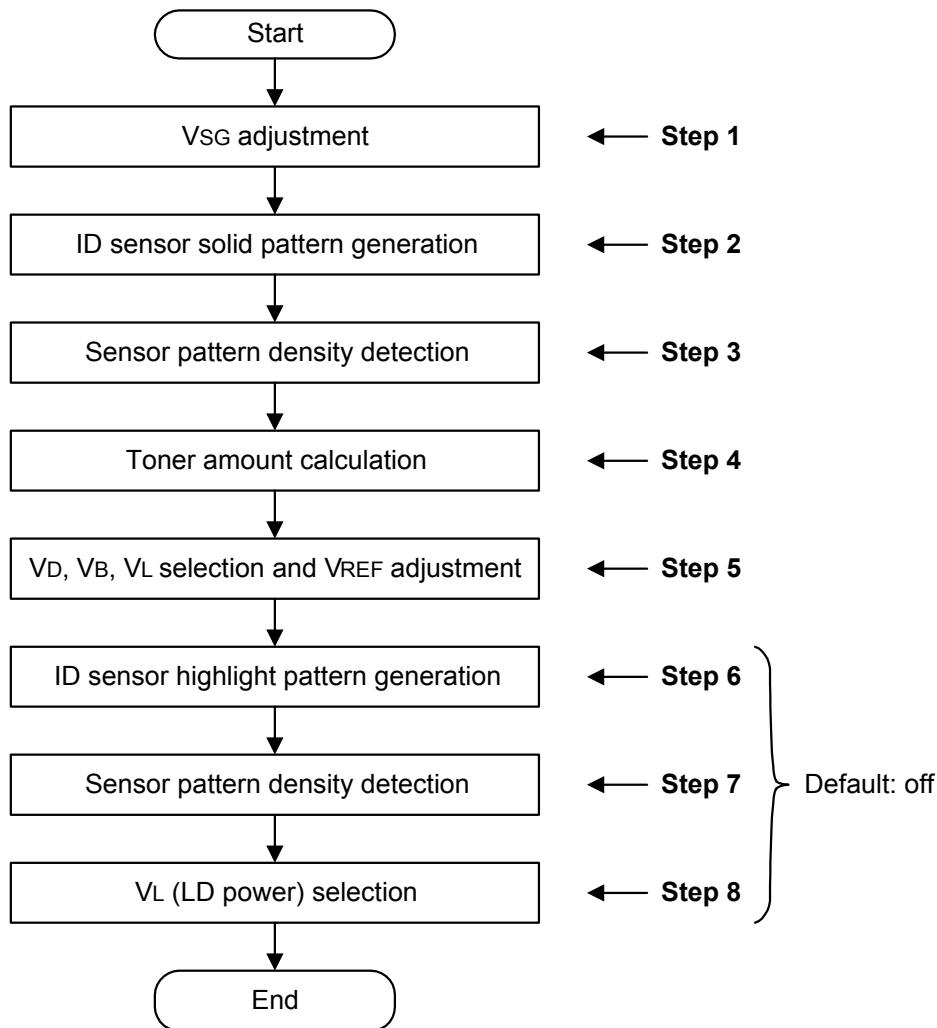

G130D506.WMF

Step 1: VSG Adjustment

This machine uses three ID sensors (direct reflection type). They are located at the front, center, and rear of the transfer unit. Only the center ID sensor is used for process control. The ID sensor checks the bare transfer belt's reflectivity. Then the machine calibrates the ID sensor until its output (known as VSG) is as follows.

- VSG = 4.0 ± 0.5 Volts

This calibration compensates for the transfer belt's condition and the ID sensor condition. For example dirt on the surface of the belt or ID sensor.

Step 2: ID Sensor Solid Pattern Generation

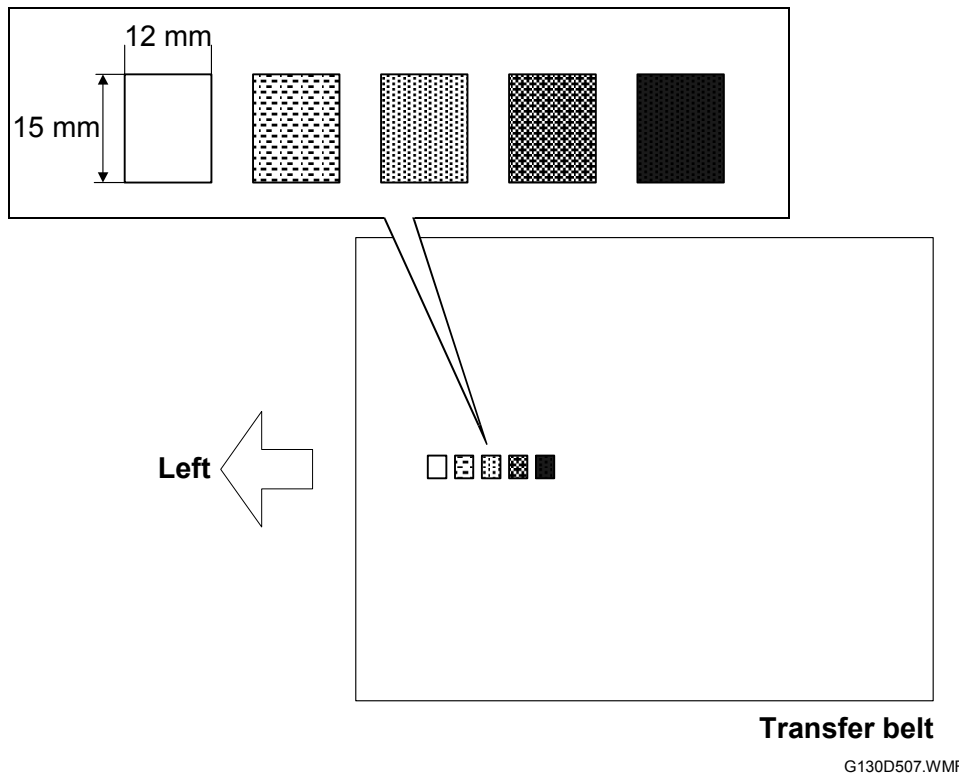

First, the machine agitates the developer for between 15 and 30 seconds until the fluctuation in TD sensor output becomes less than 0.3V.

Second, the machine makes the first series of grade patterns (see the diagram). This 5-grade pattern is made in black, yellow, cyan, and magenta (20 squares in total). They are made by changing the development bias and charge roller voltage. The difference between development bias and charge roller voltage is always the same.

Finally, the machine makes the second series of grade patterns in the same order as the first series. The development bias and charge roller voltage are not the same as those of the first series.

Detailed
Descriptions

Step 3: Sensor Pattern Detection

The ID sensor detects the densities of the 10 solid-color squares for each color (5 squares in the first series and another 5 squares in the second series). This data goes to memory.

Step 4: Toner Amount Calculation

The amount of toner on the transfer belt (M/A, mass per unit area, mg/cm^2) is calculated for each of the 10 grades of the sensor pattern from the ID sensor output value from each grade of the pattern.

Step 5: VD, VB, VL Selection and VREF Adjustment

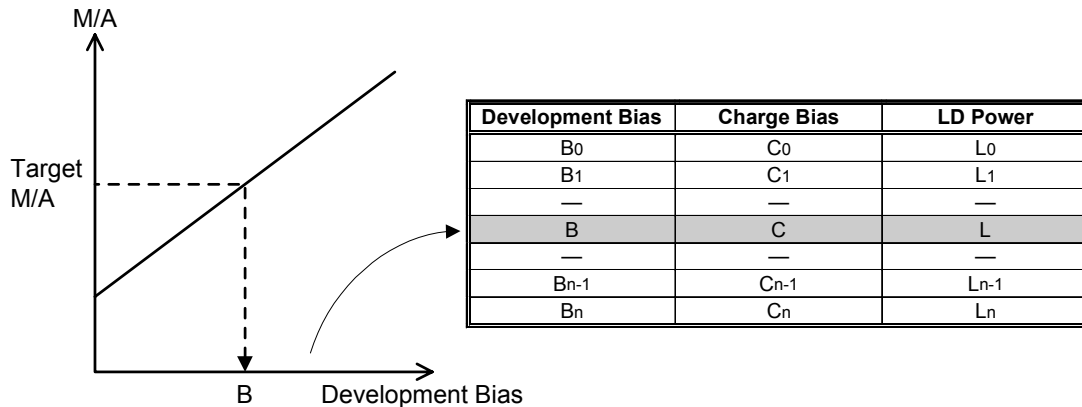

G130D508.WMF

The machine determines the relationship between the amount of toner on the transfer belt and the development bias for each of the 10 grades. Then the machine selects the development bias and charge roller voltages for the target M/A for each color by referring to a table in memory.

Laser power (VL) selected depends on the setting of SP3-125-2.

- If it is set to "Fixed", the LD power is fixed at the value of SP2-103-1, to -15.
- If it is set to "Process Control", LD power is selected using the same memory table as mentioned above.
- If it is set to "LD power", LD power is determined by ID sensor highlight pattern generation (steps 6 to 8 later in this procedure).

The machine also adjusts VREF (toner density target) at the same time so that the development gamma detected by process control will be the value stored in SP3-120-1 to -4 (do not adjust in the field unless advised to do so).

NOTE: The patterns on the transfer belt are cleaned by the transfer belt-cleaning unit.

Allowable changes to VD, VB, and VL (as a result of process control):

This depends on the process control type as follows.

- Forced: No limit
- Initial: After Developer Initialization: ± 80 volts
- Interval: (Job End/ Non-use Time/ During Toner End Recovery): ± 40 volts
- Interval: (Interrupt): Constant (The memory table is not used.)

Steps 6 to 8 are done only if SP3-125-2 is set to "LD Power". (Default: Steps 6 to 8 are not used)

Step 6: ID Sensor Highlight Pattern Generation

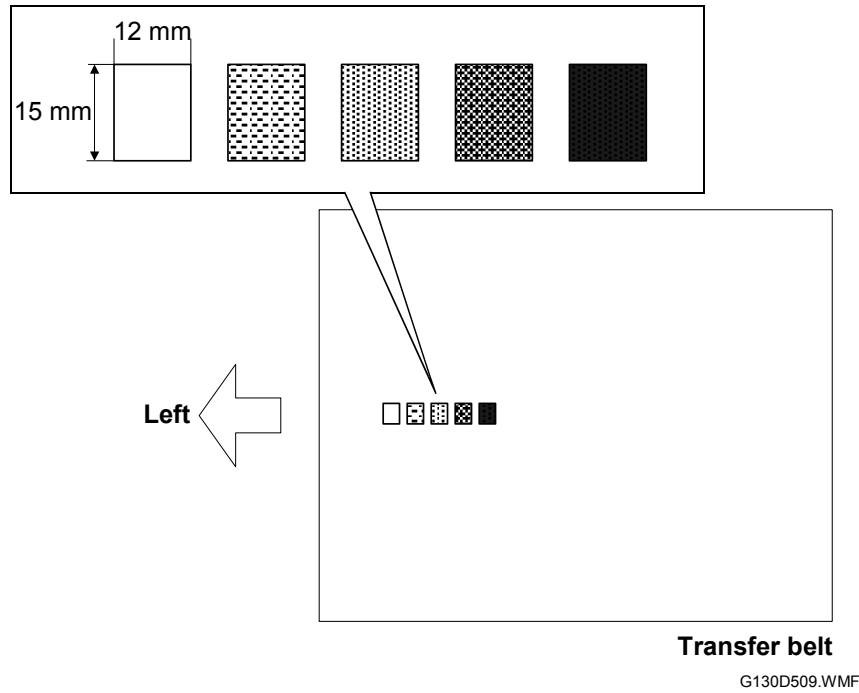

The machine makes a 10-grade pattern on the transfer belt for each toner color. The pattern has 10 squares. Each of the squares is 12 mm x 15 mm, and is a dot-pattern squares (not solid-color squares like in the process of step 2). They are made using constant bias and charge roller voltages selected from one of the types mentioned above. The various grades are made by changing the LD power.

Step 7: Sensor Pattern Density Detection

The ID sensor detects the densities of the 10 grade-pattern squares for each color. This data goes to memory.

Detailed Descriptions

Step 8: VL (LD Power) Selection

The machine determines the relationship between the amount of toner on the transfer belt and the laser power for each of the 10 grades. Then the machine selects the laser power to get the target M/A.

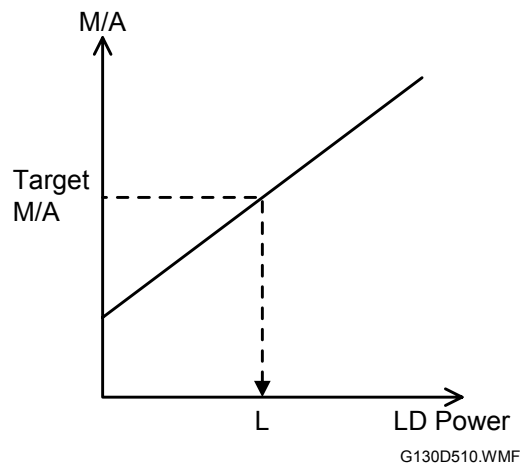

6.2.4 VREF COMPENSATION DURING A PRINT JOB

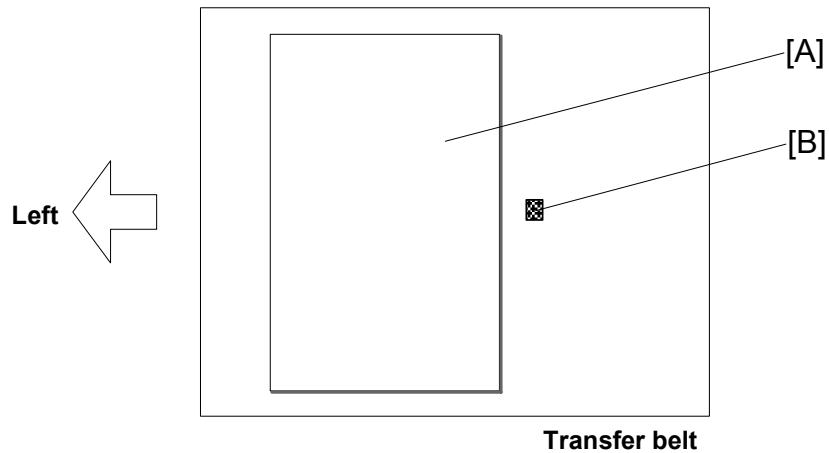

G130D511.WMF

Highlight Pattern

The M/A target (mass-per-area target) is the target toner amount in a given area. To adjust the toner amount, a highlight pattern [B] is created on the transfer. The interval of creating the highlight pattern depends on the setting specified with SP3-923 and 3-924.

For color jobs, the order of pattern generation is K → Y → M → C → K → Y → M → C. The highlight pattern is made about 2 cm after the trailing edge of the paper [A].

Adjustment Process

The machine generates a highlight pattern (one grade) of a specified density. The center ID sensor checks the density. Then the machine adjusts V_{REF} by comparing the reading with the target of each color (SP3-905-1 to 4). The machine adjusts V_{CNT} when this adjustment is not sufficient.

6.2.5 TONER SUPPLY CONTROL

Overview

Toner supply control uses the following to determine the amount of toner to be supplied. This is done before every development for each color.

- Density of the toner in the developer (detected by the TD sensor) - VREF, VT
- Pixel count

The image density is kept constant by adjusting the density of toner in the development unit. At the same time, it accommodates changes in the development conditions through the potential control mechanism. Environmental changes and the number of prints made are also used in the calculation.

The amount of toner supplied is determined by the 'on' time of the toner supply clutch. The total 'on' time for each toner supply clutch is stored in the memory chip for the relevant toner cartridge. The amount of toner supplied also depends on the process line speed for the current job. The machine supplies the calculated amount of toner for each color.

Toner Supply Control Modes

This machine has the following three toner supply control modes. You can select them with SP2-208-1 to -4.

1. Fuzzy control mode
This is the default toner supply control mode. The TD sensor, ID sensor, and pixel count are used in this mode.
2. Proportional control mode
This mode is used when the ID sensor at the center becomes faulty. Only the TD sensor is used to control toner supply. The machine uses the VREF that is stored in SP2-224-5 to -8.
3. Fixed supply mode
This mode is used when the TD sensor becomes faulty. You can adjust the amount of toner supply with SP2-208-5 to -8 if the image density is incorrect (the default setting is 5%).

6.2.6 TONER NEAR END/TONER END DETECTION

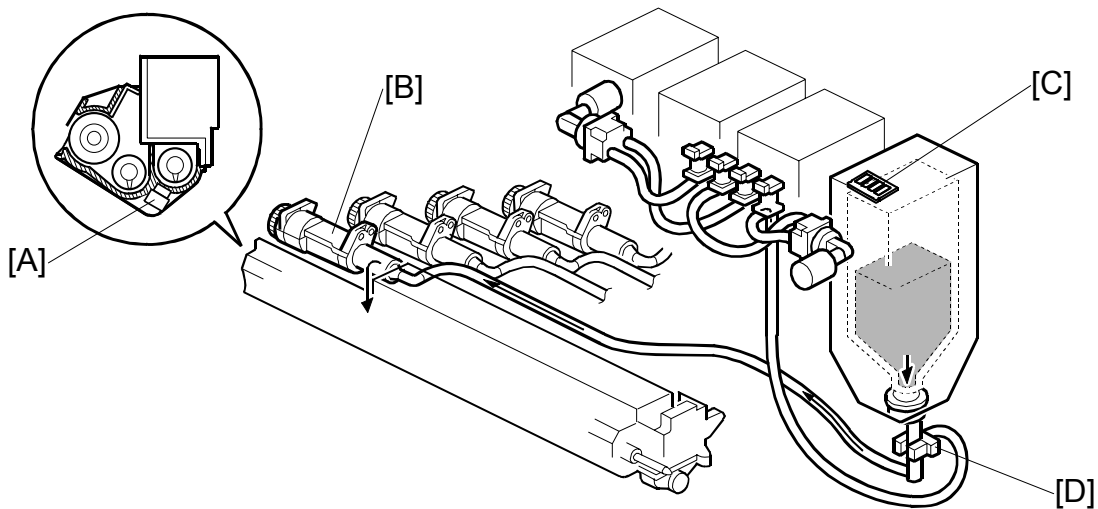

G130D512.WMF

Introduction

Toner Near End

The controller considers the following information to determine the toner near end status:

- TD sensor [A] in the development unit
- Operation time counter of the toner attraction pump [B]
- Memory chip [C] on the toner cartridge
- Toner end sensor [D]

There are two different toner near-end detection procedures (referred to as “Toner Near End Detection 1” and “Toner Near End Detection 2”). The machine enters the near-end condition if either of these gets detected.

Toner End

To determine the toner end status, the controller considers the following information:

- TD sensor [A] in the development unit
- Pixel counter

Toner Near End Detection 1

The controller considers the following information from the TD sensor:

- 1) The controller checks that the following condition is satisfied ten times consecutively:

$$V_{REF} + 0.4 \text{ V} < V_T$$

NOTE: You can adjust the condition with SP2-212.

- 2) If the above condition is satisfied, toner is supplied to the development unit. The messages, "Loading Toner" and "Please wait," show.
- 3) The controller checks the above condition again.
 - a) If the condition is satisfied, the controller decides that the machine is in the toner near end status. The yellow LED on the operation panel lights and the messages, "Toner is almost empty," "Replace Toner Cartridge(s)," and "Xxxxx," show. "Xxxxx" indicates the color, such as cyan.
 - b) If the condition is not satisfied, the controller decides that the machine is not in the toner near end status. The machine resumes its normal operation.

Toner Near End Detection 2

The controller considers the information from the operation time counter of the following:

- Toner attraction pump
 - Memory chip on the toner bottle
 - Toner end sensor.
- 1) To calculate the toner amount remaining in the toner cartridge, the controller considers the operation time counter of the toner attraction pump and the initial amount of the toner (recorded in the memory chip).
 - 2) If the amount reaches the predefined weight (default: 100 g), the controller checks the signals from the toner end sensor.

NOTE: You can adjust the weight with SP2-212-1 and -2.

- a) If the signals indicate the toner amount has fallen to a certain level (displayed with SP2-212-12 to -15), the controller decides that the machine is in the toner near end status. The yellow LED on the operation panel lights and the messages, "Toner is almost empty," "Replace Toner Cartridge(s)", and "Xxxxx," show. "Xxxxx" indicates the color, such as cyan.
- b) If the signals indicate the toner amount is not less than a certain level, the controller decides that the machine is not in the toner near end status. The machine resumes its normal operation.

Toner End Detection

The machine flags the toner end status when one of the conditions below is detected for a toner color. The red LED on the operation panel lights and the messages, “No Toner,” “Replace Toner Cartridge,” and “Xxxxx,” show. “Xxxxx” indicates the color, such as cyan.

- $V_{REF} + 0.5 V < V_T$ (ten times consecutively)
- The pixel counter counts up the equivalent of 50 A4 sheets of pixels (100% coverage) since near-end was detected.

However, printing continues if fewer pages have been made since near-end than the number set with SP2-212-11 (default: 10 pages).

NOTE: If one of the following conditions is detected 10 consecutive times, the machine flags a “toner end condition”. This condition does not depend on the number of pages printed since near-end.

- $V_{REF} + 1.2 V < V_T$
- $V_T > 4.8 V$

The machine cannot print until the toner cartridge is replaced after it detects toner end for black. The machine can print in black and white only if cyan, magenta, or yellow are in a toner end condition during standby mode. At this time the machine cannot do color print jobs.

NOTE: If the yellow, cyan, or magenta toner ends during a color-printing job, the job is suspended until toner is supplied. If new color toner is not installed, the user can print black-and-white jobs only.

Toner End Recovery

The machine assumes that the toner cartridge has been replaced if either of the following occurs when the near-end or end status exists

- The upper right cover is opened and closed.
- The main switch is turned off and on.

Then the machine starts to supply toner to the development unit. After supplying toner, the machine clears the toner near-end or end status if the following conditions are detected:

- $V_t [0] - V_t [3] > 0.5V$
- $V_t - V_{ref} > 0.3V$

6.2.7 DEVELOPER INITIALIZATION

When the machine detects that a new development unit has been installed, it initializes the developer.

To do this, the machine agitates the developer for about 100 seconds, and adjusts V_{CNT} (control voltage for TD sensor) so that V_T (TD sensor output) becomes 3.5 ± 0.1 volts. The machine stores this V_T as V_{REF} .

V_{CNT} is corrected for the current humidity every print job. V_{CNT} is also corrected for the total number of prints, to prevent the developer Q/M from varying.

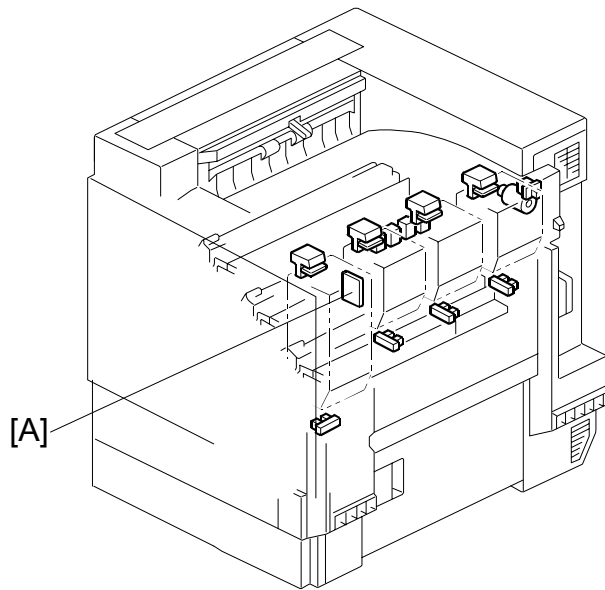

G130D922.WMF

If the humidity correction is giving poor results (for example, if the humidity sensor [A] is broken), it can be disabled with SP2-223-2. Then a value for V_{CNT} must be input manually using SP2-224-1 to -4 (adjust by trial and error).

During developer initialization, the machine forcibly supplies toner because there is no toner inside the toner transport tube at installation. Then the machine does the process control self check.

6.3 LASER EXPOSURE

6.3.1 OVERVIEW

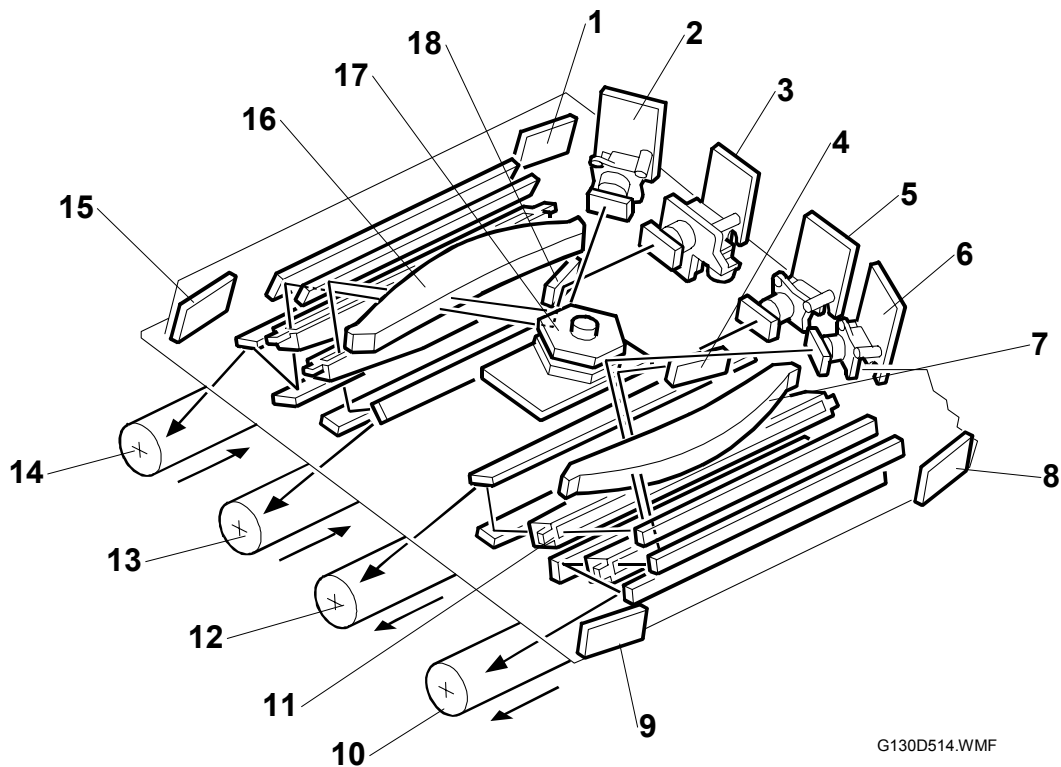

G130D514.WMF

- | | |
|--|---|
| 1. Synchronizing detector board-Y, K-E | 10. OPC drum-M |
| 2. LD unit-Y | 11. WTL |
| 3. LD unit-K | 12. OPC drum-C |
| 4. LD Mirror-M | 13. OPC drum-Y |
| 5. LD unit-M | 14. OPC drum-K |
| 6. LD unit-C | 15. Synchronizing detector board-Y, K-S |
| 7. F-theta lens-M, C | 16. F-theta lens-Y, K |
| 8. Synchronizing detector board-M, C-S | 17. Polygon mirror motor |
| 9. Synchronizing detector board-M, C-E | 18. LD Mirror-K |

This machine uses four LD units and one polygon mirror motor to produce latent images on four OPC drums (one drum for each color toner).

There are two hexagonal mirrors. Each mirror reflects beams from two LD units.

Laser exposure for magenta and cyan starts from the rear side of the drum. But for yellow and black it starts from the front side of the drum. This is because the units for magenta and cyan are on the other side of the polygon mirror from the units for yellow and black.

6.3.2 OPTICAL PATH

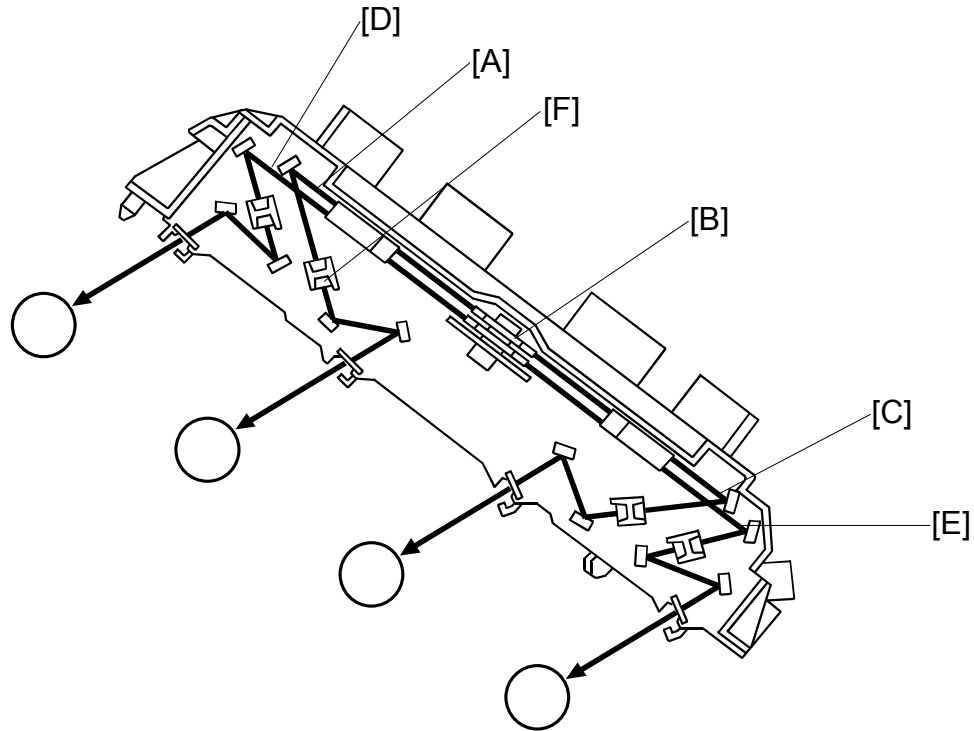

G130D515.WMF

The laser beams for cyan [C] and yellow [A] are directed to the upper part of the polygon mirror [B]. Laser beams for magenta [E] and black [D] are directed to the lower part of the polygon mirror. The LD mirrors (see the previous page) deflect the laser beams for magenta and black towards the lower polygon mirror.

The WTL [F] corrects the main scan line. Without this component, the line bends out towards the middle of the main scan. The central bend of the WTL is adjusted in the factory.

The speed of the polygon mirror depends on the selected mode and model (see below).

Detailed Descriptions

Mode	Resolution (dpi)	Polygon motor speed (rpm)	Process line speed (mm/s)	Print speed (ppm)	Remarks
B/W (except OHP/Thick paper)	600 x 600 1,200 x 600	38268	162	G130: 32 G131: 35	
	1,200 x 1,200	38268	81	17	
Color (except OHP/Thick paper)	600 x 600 1,200 x 600	G130: 29528 G131: 38268	G130: 125 G131: 162	G130: 28 G131: 35	
	1,200 x 1,200	38268	81	17	
OHP/Thick	600 x 600 1,200 x 600 1,200 x 1,200	38268	81	14	

6.3.3 LASER SYNCHRONIZING DETECTOR

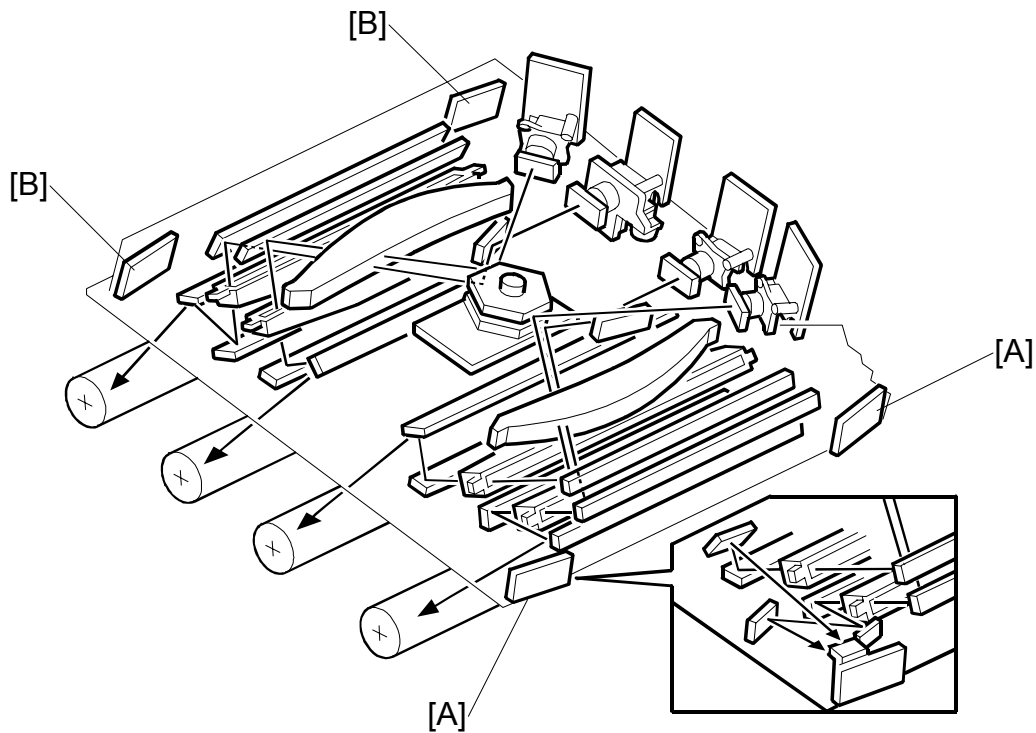

G130D516.WMF

Overview

The machine has four laser synchronizing detector boards (LSD). There is one at each corner of the laser optics-housing unit.

Each pair of boards detects two colors. The machine recognizes each color from the time that they are detected. The two LSDs at the right [A] are used for magenta and cyan. The two LSDs at the left [B] are used for yellow and black.

Main Scan Start Detection

For magenta and cyan, the LSD at the rear detects the start of the main scan. For yellow and black, the LSD at the front detects the start of the main scan.

Clock Frequency Adjustment

Each pair ensures that the number of laser clock pulses in the main scan is constant. If the count for one particular beam varies from normal, the LD clock frequency for that beam is adjusted.

If the board at the end position is defective, this cannot be detected. At this time, you must disable the detection feature with SP2-919-1.

6.3.4 LD SAFETY SWITCH

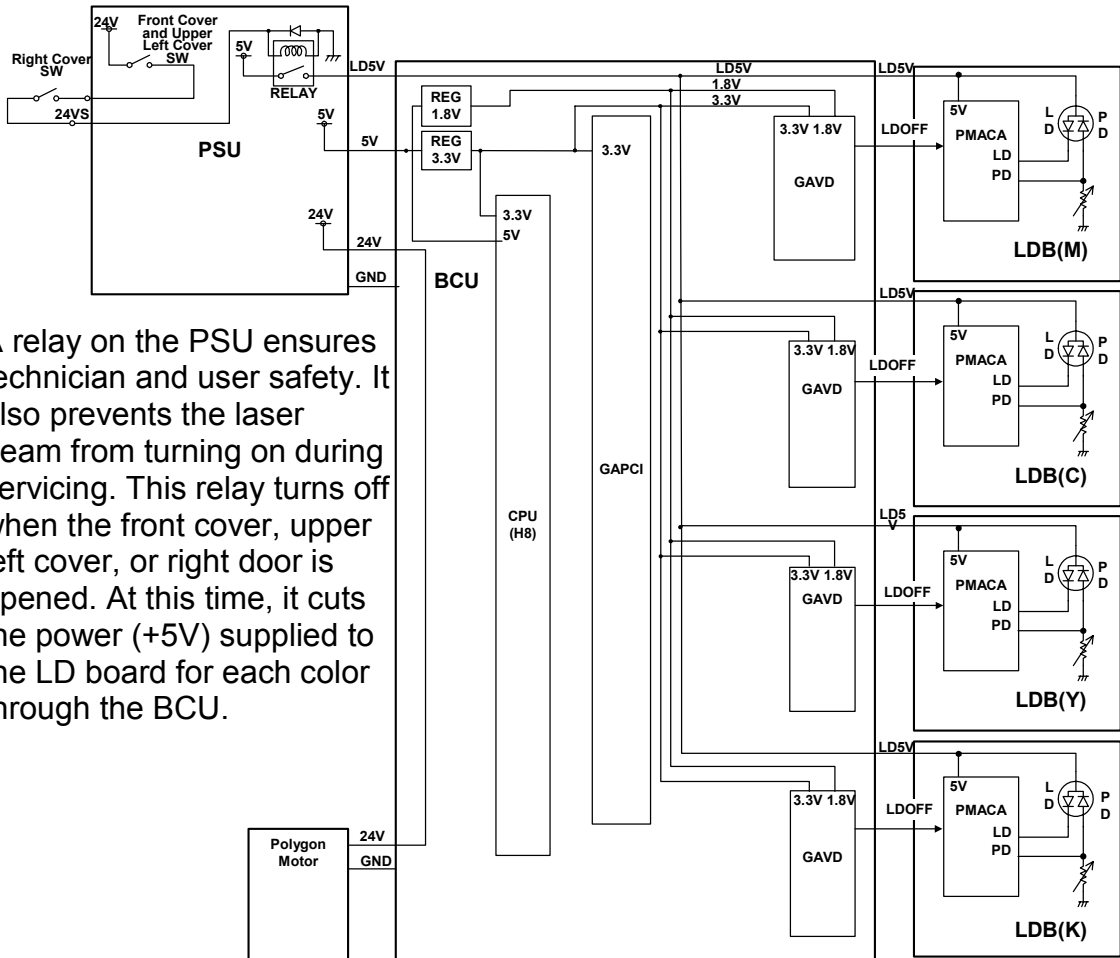

A relay on the PSU ensures technician and user safety. It also prevents the laser beam from turning on during servicing. This relay turns off when the front cover, upper left cover, or right door is opened. At this time, it cuts the power (+5V) supplied to the LD board for each color through the BCU.

G130D901.WMF

Two safety switches are used to turn the relay off. One switch is used for the front cover and upper left cover. This safety switch is off when either of the two covers is opened. The other safety switch is used for the right door.

- PMAC: Precise Pulse Modulation ASIC on C-MOS technology
- LDB: LD Drive Board (included in the LD Unit)

Front and Upper Left Cover Switch

The micro switch [A] on the PSU is activated or deactivated by the actuator [B] when the front cover or the upper left cover is opened and closed.

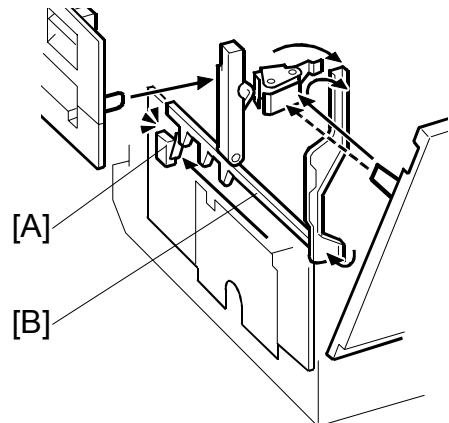

G130D520.WMF

Detailed Descriptions

Error Messages

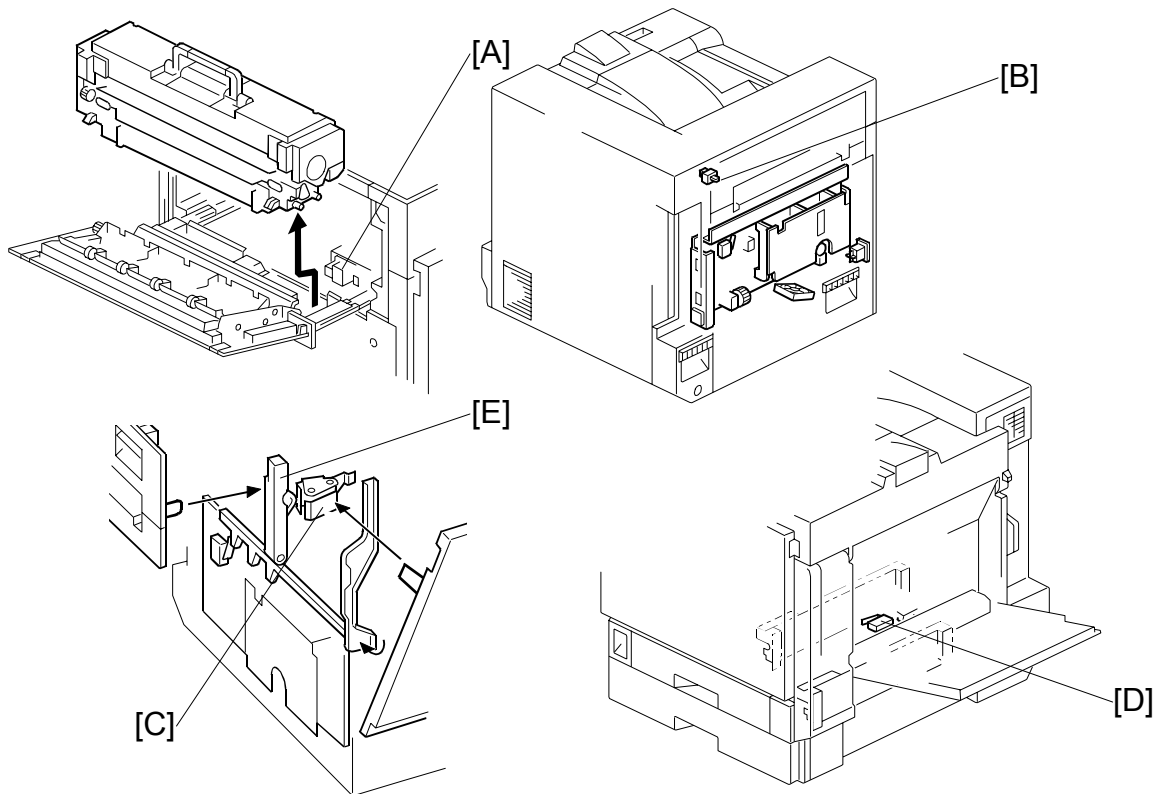

G130D521.WMF

The LD safety switches along with other electrical components help to show error messages related to external covers and doors. The table lists the error messages and their error conditions. Note that some messages take precedence over others.

Message	Condition			
	[A] Fusing unit link	[B] Upper left cover switch	[C] Front door switch	[D] Right door switch
Reset Fusing Unit Correctly	Open	(any)	(any)	(any)
Close Upper Left Cover	Connected	Open	(any)	(any)
Close Front Cover	Connected	Closed	Open	(any)
Close Right Cover	Connected	Closed	Closed	Open

- NOTE:** 1) In the table, “any” indicates that the condition does not affect the diagram indication.
 2) The left door switch [E] is closed when the upper left cover switch [B] is closed.

6.3.5 AUTOMATIC LINE POSITION ADJUSTMENT

Overview

YY, KK, CC, MM: Spaces between two lines of the same color
KY, KC, KM: Spaces between a black line and a color line

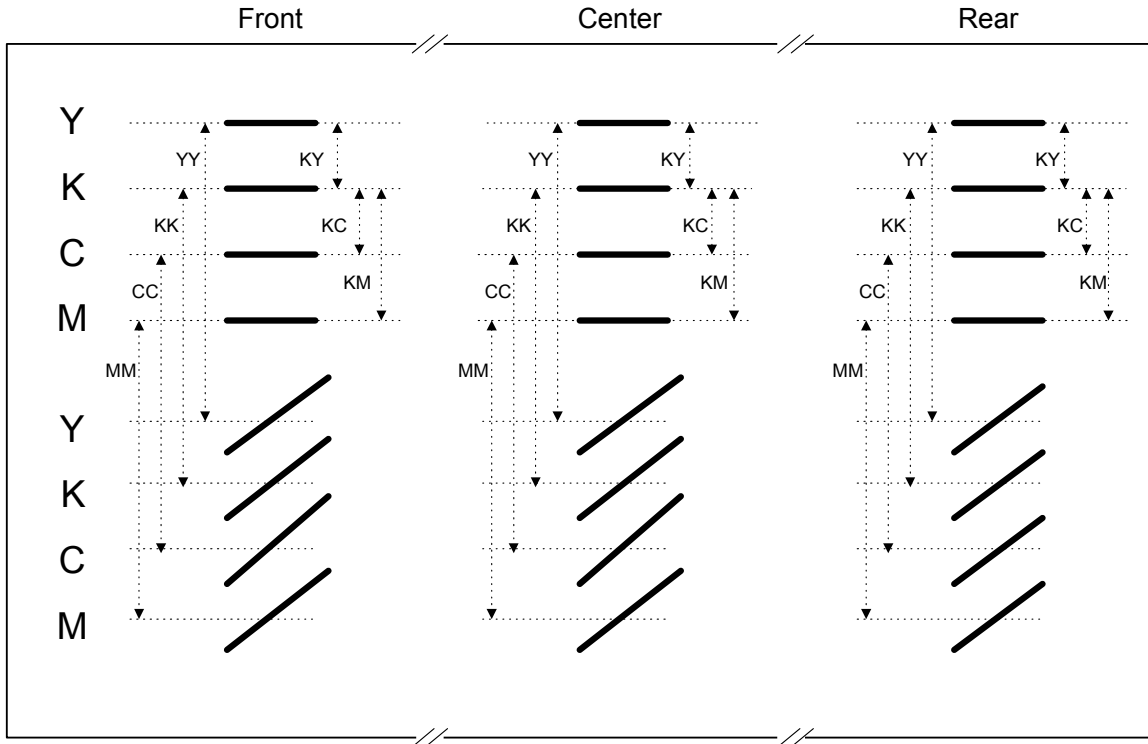

G130D522.WMF

During automatic line position adjustment, the line patterns above are created eight times on the transfer belt. The spaces between the lines (YY, KK, CC, MM, KY, KC, KM) are measured by the front, center, and rear ID sensors. The controller takes the average of the spaces. Then it adjusts the following positions and magnification:

- Sub scan line position for YCM
- Main scan line position for YCM
- Magnification ratio for KYCM
- Skew for YCM

The transfer belt-cleaning unit cleans the transfer belt after the patterns are measured. SC285 shows if an error is detected four times consecutively.

Detailed Descriptions

Summary of Each Adjustment***Sub scan line position for YCM***

The adjustment of the sub-scan line position for YCM is based on the line position for K (color registration). The machine measures the gaps between the lines of each color in the pattern on the transfer belt. If the gaps for a color are not correct, the machine moves the image of the color up or down the sub scan axis. To do this, it changes the laser write timing for that color.

Main scan line position for YCM

If the machine detects that the image is out of position in the main scan direction, it changes the laser write start timing for each scan line.

Magnification adjustment for KYCM

If the machine detects that magnification adjustment is necessary, it changes the LD clock frequency for the required color.

Skew for YCM

The adjustment of the skew for YCM is based on the line position for K.

Adjustment Conditions

Line position adjustment timing depends on several SP mode settings. But the mode selection, SP5-993-001, takes precedence over the others. The table below shows the conditions and the processes you need to do. Note that the adjustments of the sub-scan line position, main scan line position, and magnification are done under the same conditions.

The numbers in the mode selection column show the setting of SP 5-993-001. For details, refer to the description for SP 5-993-001 in the SP table.

Mode selection	Condition		Setting	S-pos./ M-pos./ Magni.	Skew
1	Process control	Job End	SP3-906-001	✓	
		Interrupt	SP3-906-002	✓	
		Non-use Time 1, 2	SP3-906-003, 004	✓	
		Power On Interval Time	SP3-906-006	✓	
		Recovery (fusing temperature 60°C or lower)	SP3-125-007	✓	✓
1 or 2	Temperature difference	Standby	SP5-993-003, 005	✓	
		Job start	SP5-993-003, 006	✓	
		Interrupt	SP5-993-003, 04, 022	✓	
	Main scan length detection	SP2-919-001	✓*		
	Initialization (fusing temperature over 60°C)	SP5-993-026	✓		
	Replacement of development unit or PCU	None	✓	✓	
0, 1, or 2	Forced self check		SP5-993-002	✓	✓

S-pos. : Sub-scan line position ✓ : Executed
M-pos. : Main scan line position ✓* : Executed one time when the
Magni. : Magnification conditions are met twice

- NOTE:** 1) "Recovery" includes turning on the main switch.
2) Fusing temperature is measured by the thermistor in the fusing unit. Other temperatures are measured by the sensors on the laser optics-housing unit.
3) You can use SP5-993-035 to select one of the six frequency levels of the line position adjustment.

Detailed
Descriptions

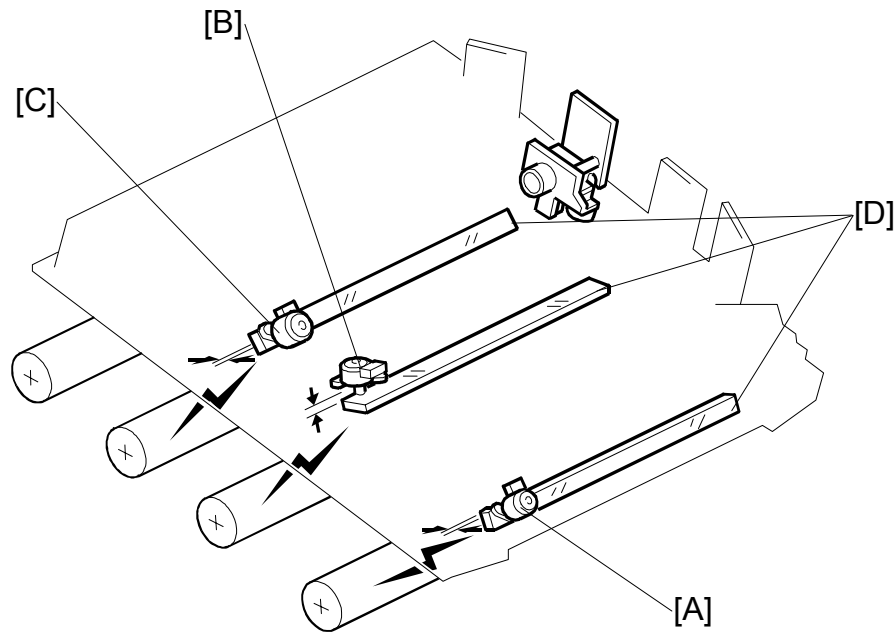
Main Scan Skew Adjustment

G130D523.WMF

The 3rd mirror positioning motors for magenta [A], cyan [B], and yellow [C] adjust the angle of the 3rd mirrors [D] respectively, based on the 3rd mirror position for black. This mechanism corrects main scan skew.

6.4 PHOTOCONDUCTOR UNIT

6.4.1 OVERVIEW

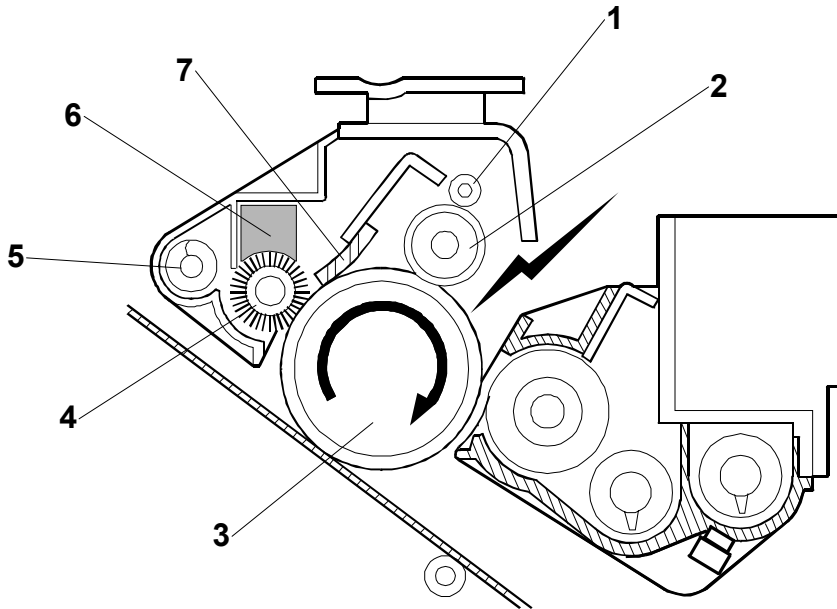

- | | |
|--------------------------------|---------------------------------|
| 1. Cleaning brush roller | 5. Waste toner collection auger |
| 2. Charge roller (non-contact) | 6. Lubricant bar |
| 3. OPC drum | 7. Cleaning blade |
| 4. Cleaning brush | |

This machine has four independent PCUs, one for each color. Each PCU has the following:

- 1) OPC drum
- 2) Non-contact charge roller
- 3) Cleaning brush
- 4) Cleaning blade.
- 5) Lubricant bar

The diameter of the drum is 30 mm (circumference: about 94.25 mm).

The photoconductor gap between a PCU and the corresponding development roller is determined by the drum positioning plate and the rear shaft. You cannot adjust this in the field.

The push switches in the drum positioning plate detect when a new PCU has been installed.

6.4.2 DRIVE

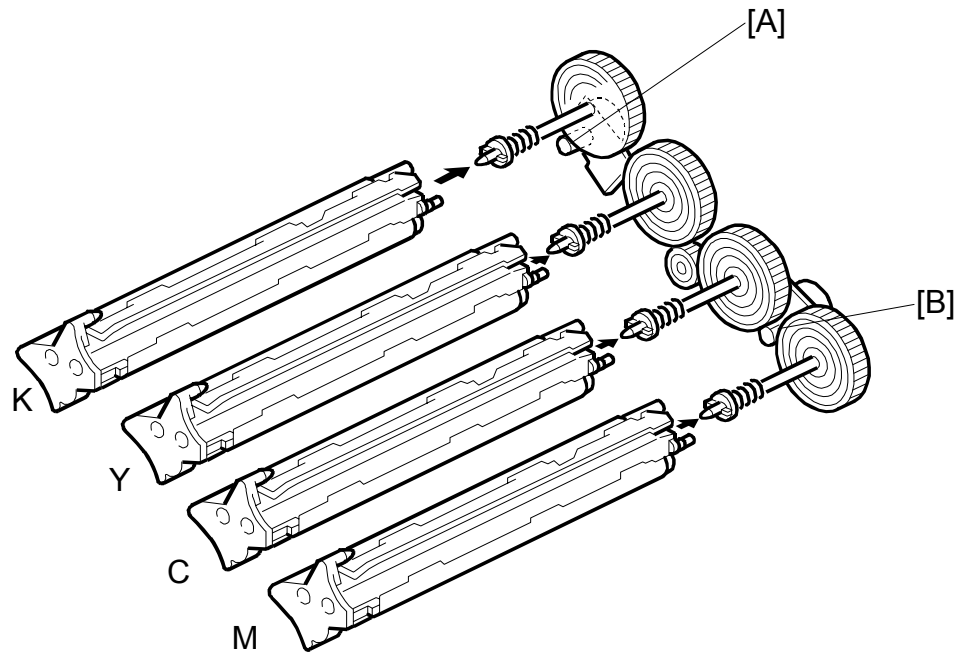

G130D525.WMF

The drum drive motor-K [A] drives the PCU for black.

The drum drive motor-CMY [B] drives the PCUs for magenta, cyan, and yellow. Using one motor to drive these three drums reduces CMY color misalignment.

Both motors are brush-less DC motors. This helps to reduce the drive noise. The brush-less DC motors make sound that is not the same as other machines, but this sound does not mean machine defective.

6.4.3 DRUM GEAR POSITION SENSORS

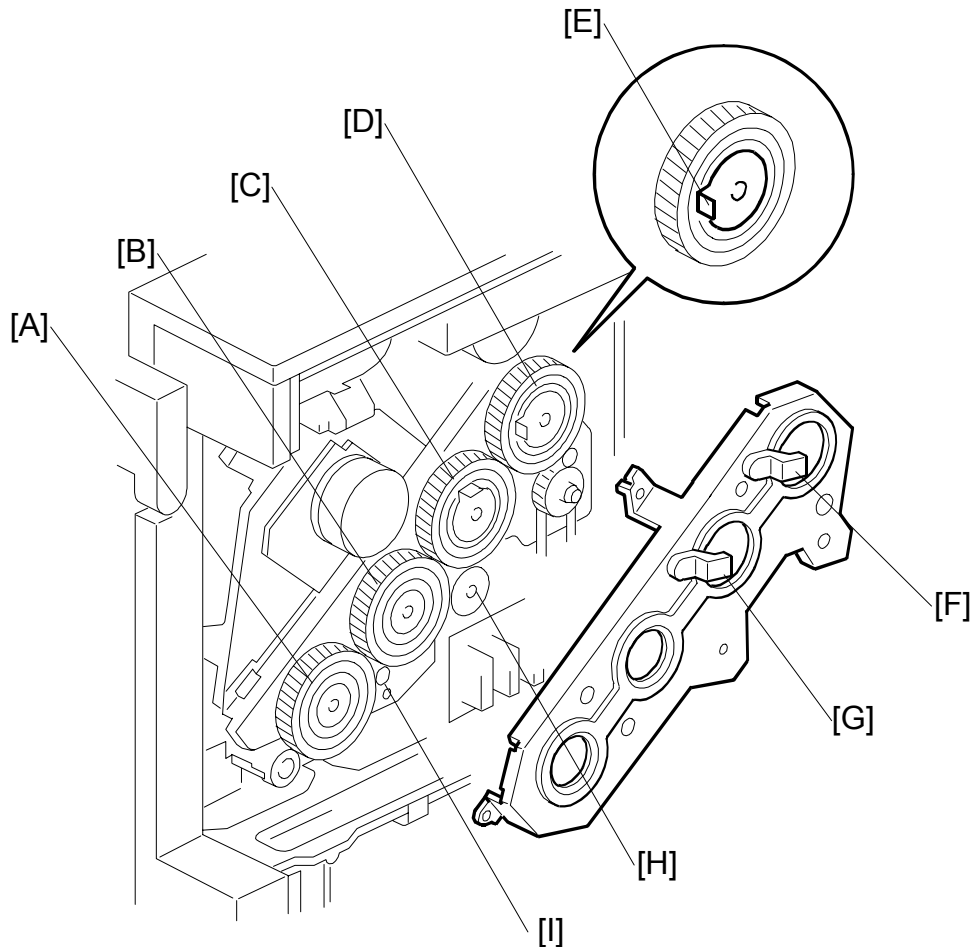

G130D526.WMF

Mechanism

The machine uses these sensors to detect if the drum motors rotate. SC440 shows when it detects that the drum motor is not moving. These sensors also help the machine to initialize the relative positions of the gears when the main switch is turned on, and during initializing. This prevents phase fluctuation between printouts.

There is an interrupter [E] on each of the black [D] and yellow [C] drum gears. The drum gear position sensors [F][G] detect the positions of these interrupters respectively. The sensors check that the two interrupters are parallel. This mechanism makes sure that output quality does not vary. The cyan [B] and magenta [A] drum gears operate with the yellow drum gear because these three drum gears are linked through other gears [H][I].

In the ready status, the two interrupters stay in a parallel position. If they are not in a parallel position (shown in the illustration), the machine adjusts the position of the black drum gear.

The relative positions of the gears are adjusted every 30 jobs. This takes one second or less. The message "Please Wait" shows during the adjustment.

Initialization Process and SC Codes

SC code 440-1 or 440-2 show when a drum gear position sensor detects an error. The table shows the following:

- Steps of the initialization process
- Possible errors
- Corresponding SC codes.

	Initialization process	Possible error	SC code
Step 1	The four drums simultaneously operated\ for seven seconds. The two drum position sensors detect the two drum gear interrupters several times.	The black drum gear interrupter is not detected.	440-1
		The yellow drum gear interrupter is not detected.	440-2
		Both black and yellow drum gear interrupters are not detected.	440-1
Step 2	The time lags between detection of the black drum gear interrupter and detection of the yellow drum gear interrupter are checked. The average time lag is calculated.		
Step 3	The black drum is operated. The position of the gear is adjusted according to the average time lag.	The black drum gear interrupter is not detected (●NOTE).	440-1

NOTE: No error occurs in step 1 and step 2 if the connector of the black drum position sensor has been connected to the yellow drum position sensor (and the connector of the yellow drum position sensor, to the black drum position sensor).

6.4.4 DRUM CHARGE AND QUENCHING

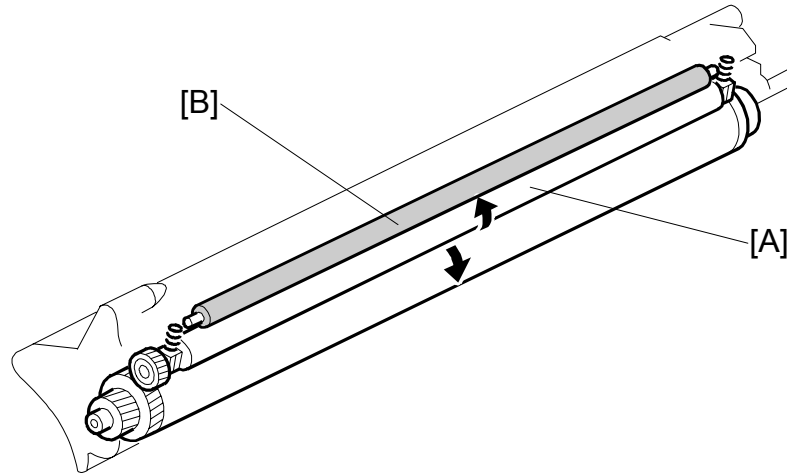

G130D527.WMF

This machine uses a non-contact charge roller [A] to reduce ozone. The non-contact charge roller gives the drum surface a negative charge. The high voltage supply board – C.B, which is located at the rear of the machine, applies a dc and ac voltage (at a constant current) to the roller. The ac voltage helps to ensure that the charge given to the drum is as uniform as possible.

The machine automatically controls the charge roller voltage if automatic process control is enabled (i.e., if SP3-125-1 is set to "ON"). However, if process control is switched off, (i.e., if SP3-125-1 is set to "OFF"), the dc voltage is the value stored in SP2-001-1 to -4 (do not adjust in the field unless advised to do so).

The diameter of the roller is 11.14 mm (circumference about 35 mm). The gap between a drum and the corresponding charge roller is about 50 μ m.

The cleaning brush roller [B], which always contacts the charge roller, cleans the charge roller.

The charge roller can generate small amounts of nitrogen oxide gases (known as NOx). These gases can stay on the surface of the drum. This can cause unfocused copies. To avoid this, the film of NOx is removed at the following times:

- Power on
- At the end of a job (if more than 200 prints)
- When a toner cartridge has been replaced

SP3-920-1 to -4 determines when this procedure (known as "refresh mode") is done. You can do this at any time with SP3-920-5 if the prints are smeared.

Quenching is done by illuminating the whole area of the drum with the laser at the end of every job.

6.4.5 DRUM CLEANING

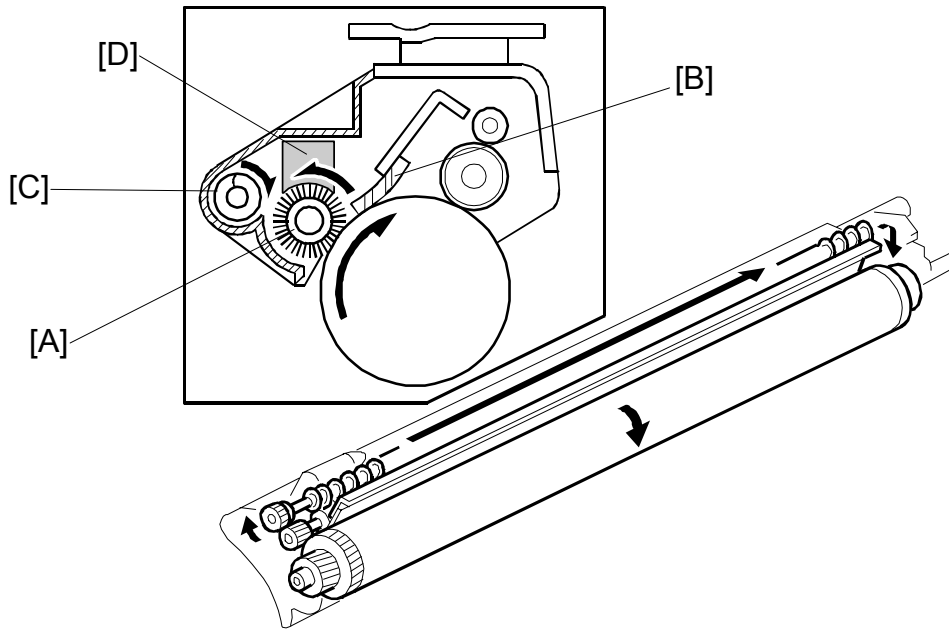

G130D528.WMF

The cleaning brush [A] spreads out the waste toner that stays on the drum. Then the cleaning blade [B] scrapes it off. The toner collection auger [C] transports the toner towards the waste toner collection duct.

The lubricant bar [D] is on the cleaning brush. The cleaning brush rubs against the lubricant bar and lubricates the drum surface. Excess lubricant is removed by the cleaning blade. Then it goes to the waste toner collection duct.

6.4.6 WASTE TONER COLLECTION

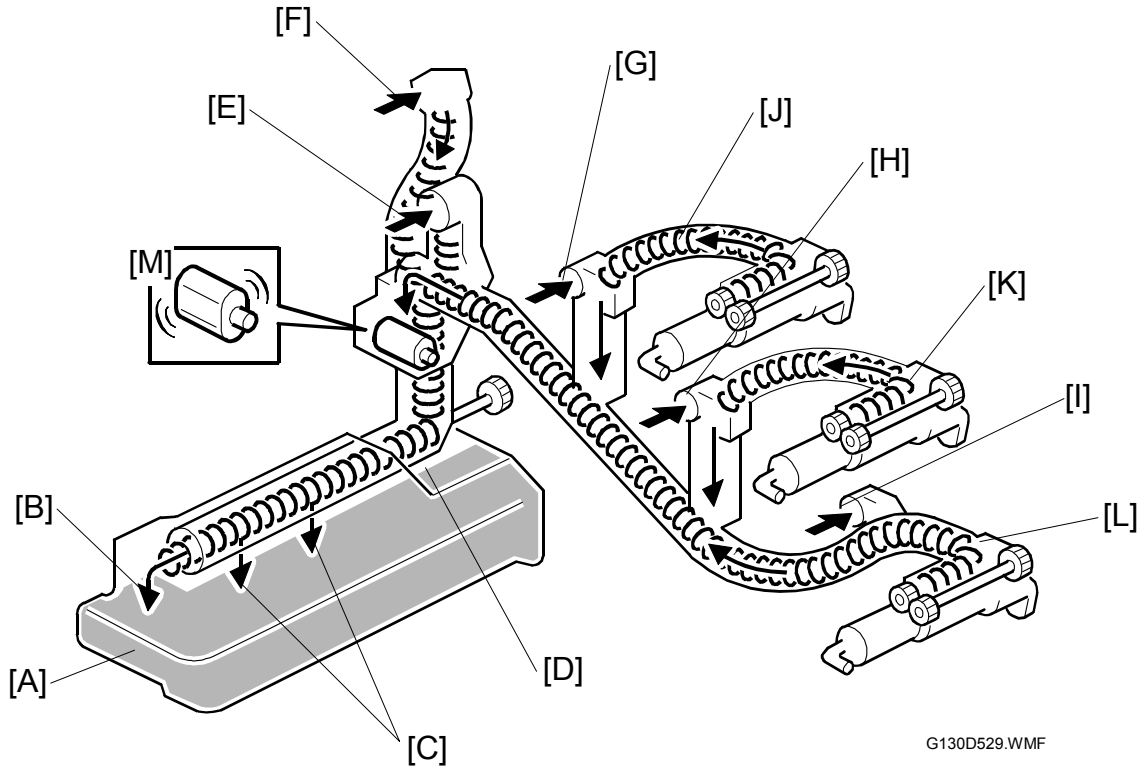

G130D529.WMF

Waste Toner Path

The waste toner from the collection augers in the four PCUs drops into the waste toner collection duct from the four openings [F][G][H][I] at the rear of the PCUs. The toner collection coils [J][K][L] in the duct transport this waste toner towards the waste toner bottle [A]. The coils [J][K][L] are driven by development drive motor-CMY. The openings and PCUs correspond as follows: black → [F], yellow → [G], cyan → [H], magenta → [I].

The waste toner from the transfer belt-cleaning unit drops into the waste toner collection duct from another opening [E].

The end of the waste toner collection duct is in the waste toner bottle [A]. There are three openings [B][C] and one collection coil [D] in this part. The waste toner drops into the bottle through the openings. The collection coil [D] is driven by drum drive motor-K.

Detailed Descriptions

Waste Toner Vibrator

The waste toner vibrator has one motor [M]. The motor operates for about one second at a time. Its vibration does not let waste toner clog the waste toner path.

The table shows the conditions under which the motor operates.

Machine status	Motor operation
During machine start (machine initialization)	Two times
At the beginning of the process control	One time
Printing jobs that output five or less papers	At the job end if 3 or more papers have been output since the previous operation (of the motor) (①)
Printing jobs that output 6 or more papers	Every five papers and at the job end (②)

Case 1: The machine does two jobs. The first job outputs one paper, and the second job outputs two papers. In this case, the motor operates one time at the end of the second job (see ①).

Case 2: The machine does one job, and the job outputs 12 papers. In this case, the motor operates at the following times:

- One time during the fifth printing
- One time during the tenth printing
- One time at the job end (see ②).

Case 3: The machine does two jobs. The first job outputs one paper, and the second job outputs 12 papers. In this case, the motor operates at the following times:

- One time during the fifth printing of the second job
- One time during the tenth printing of the second job
- One time at the end of the second job (see ②; This case does not satisfy condition ①).

6.4.7 WASTE TONER BOTTLE FULL DETECTION

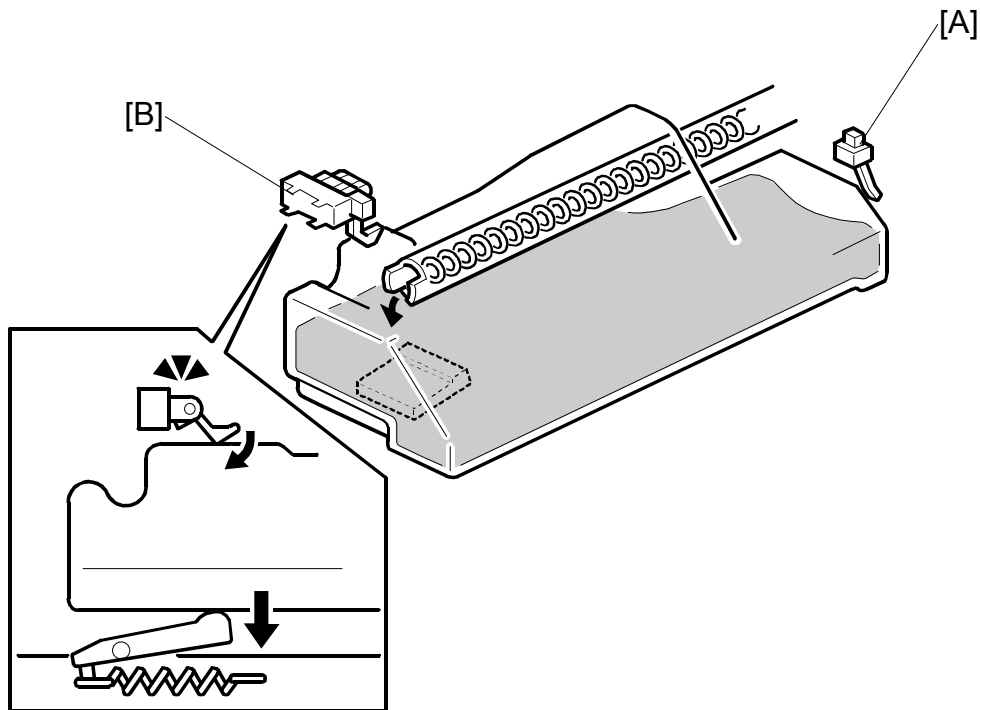

G130D530.WMF

The waste toner bottle set switch [A] detects the bottle when it is placed in the machine.

The waste toner sensor [B] detects the weight of the bottle and informs the machine when it is almost full.

When the bottle contains a certain amount of waste toner, the sensor is deactivated. The machine detects that the waste toner bottle is almost full and shows "Waste Toner is Almost Full".

At this time, the machine can print about 2,500 more sheets. After printing 2,500 sheets, it shows "Replace Waste Toner," at the end of the job. After this, you cannot use the machine again until the bottle is replaced or emptied.

NOTE: The number of sheets is calculated on the assumption that the paper size is A4 and that the coverage ratio of each color is 5%.

6.5 DEVELOPMENT

6.5.1 OVERVIEW

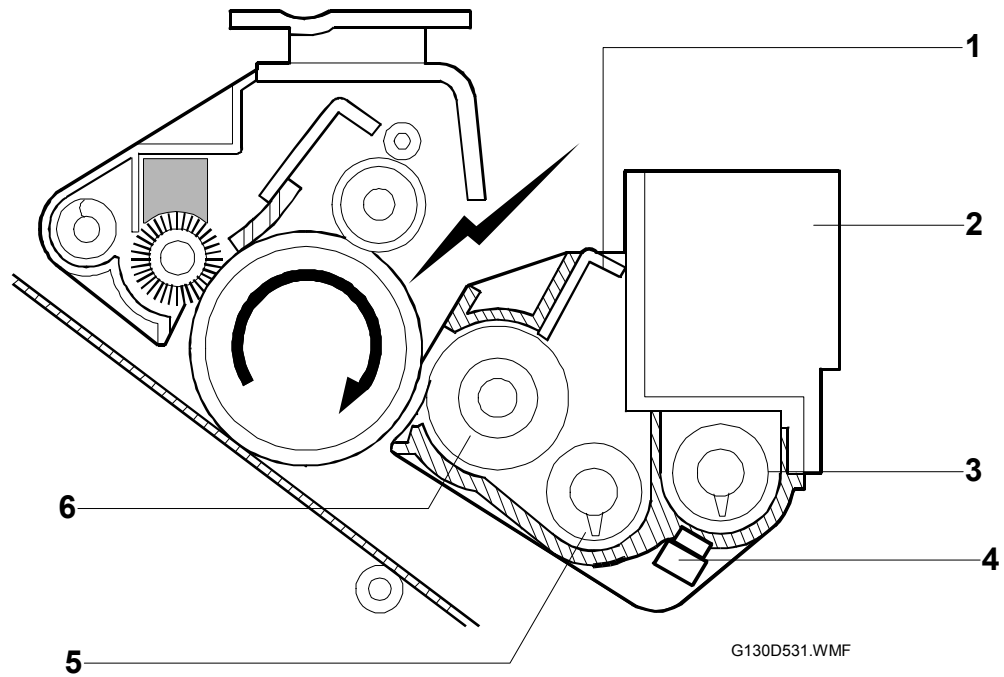

- | | |
|-------------------------|------------------------|
| 1. Doctor blade | 4. TD sensor |
| 2. Developer hopper | 5. Mixing auger (left) |
| 3. Mixing auger (right) | 6. Development roller |

This machine has four independent development units, one for each color. Each contains 300 g of developer when new. The developer in each unit is supplied to the development roller by the two mixing augers and attracted onto the surface of the roller.

The photoconductor gap between PCU and development roller is determined by the drum positioning plate and the rear shaft. You cannot adjust this in the field.

The push switches in the drum positioning plate detect a new development unit when it has been installed, and detect whether the development unit is in the machine.

The TD sensor and center ID sensor control toner density. Each development unit has a TD sensor.

The diameter of the development roller is 18.2 mm (circumference about 57.2 mm).

6.5.2 DRIVE

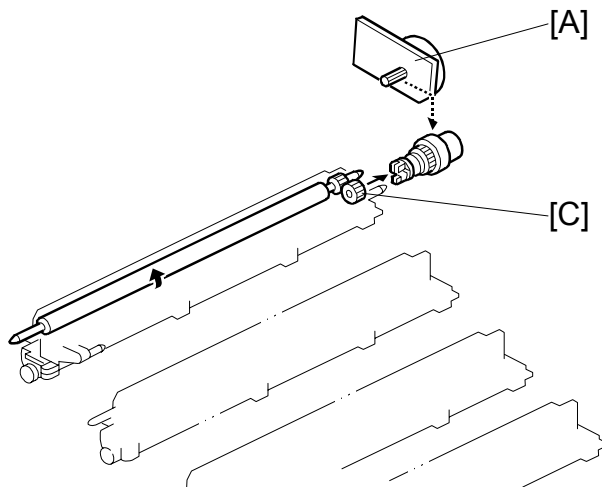

G130D532.WMF

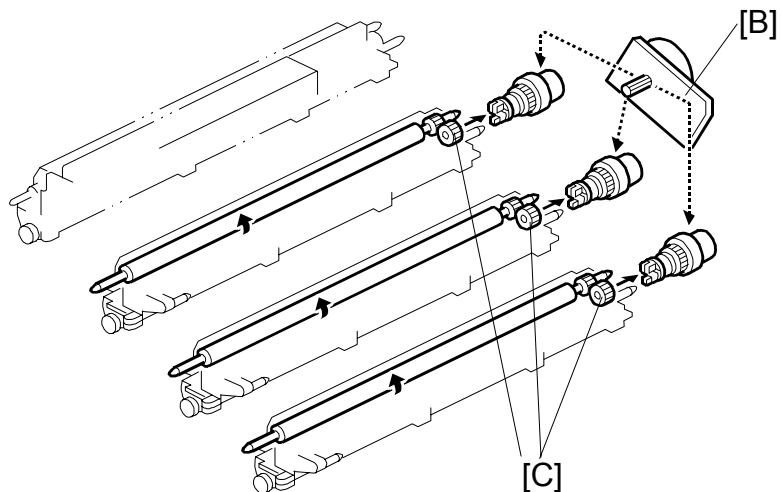

G130D533.WMF

Detailed
Descriptions

The development drive motor-K [A] drives the development roller for black through gears and a clutch. This motor also drives the fusing unit and paper exit rollers. The gear trains are shown in the diagram by dotted lines.

The development drive motor-CMY [B] drives the development unit for magenta, cyan, and yellow through gears and clutches. This motor also drives the registration roller.

The drive gears [C] of the development units are flexible. This creates a smooth connection between the development motor gear and the drive gear of the development unit.

6.5.3 DEVELOPER AGITATION

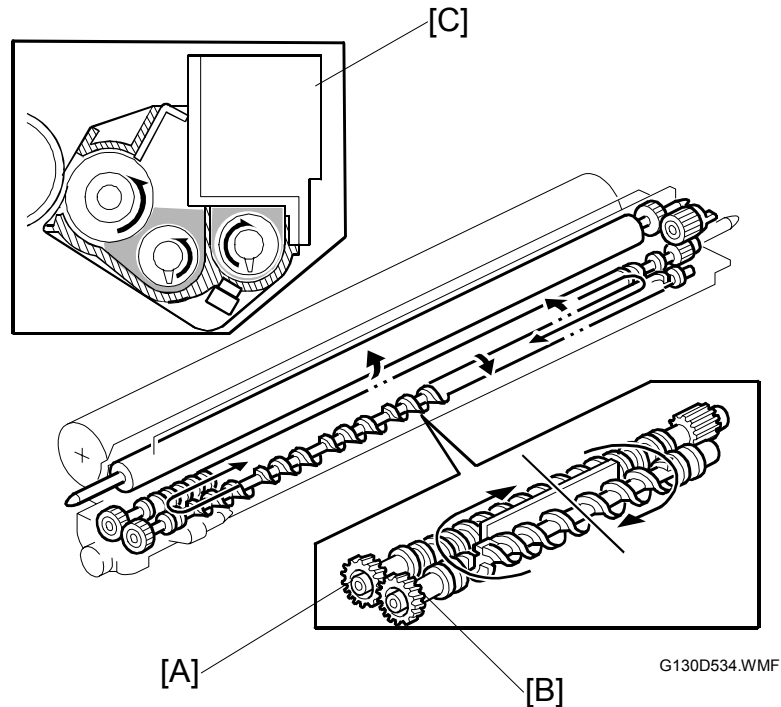

Two mixing augers [A and B] circulate the developer forward and backward to agitate the developer.

This happens at the following times:

- During process control self check
- During toner supply
- During development.

Ducts on the top of the developer hopper [C] make sure that the internal pressure does not become too high. These ducts are sealed to not let the toner solidify.

This development unit does not operate very well at high temperatures (over 50° C). The toner inside the development unit can become solid at temperatures higher than this value. A developer initialization error shows if the toner does become solid. At this time, you must do the following procedure:

NOTE: You should also do this procedure when you install a new development unit.

1. Remove the (old) development unit.
2. Keep the (new) development unit level and shake it several times from side to side.
3. Install it to the machine.

6.5.4 DEVELOPMENT BIAS

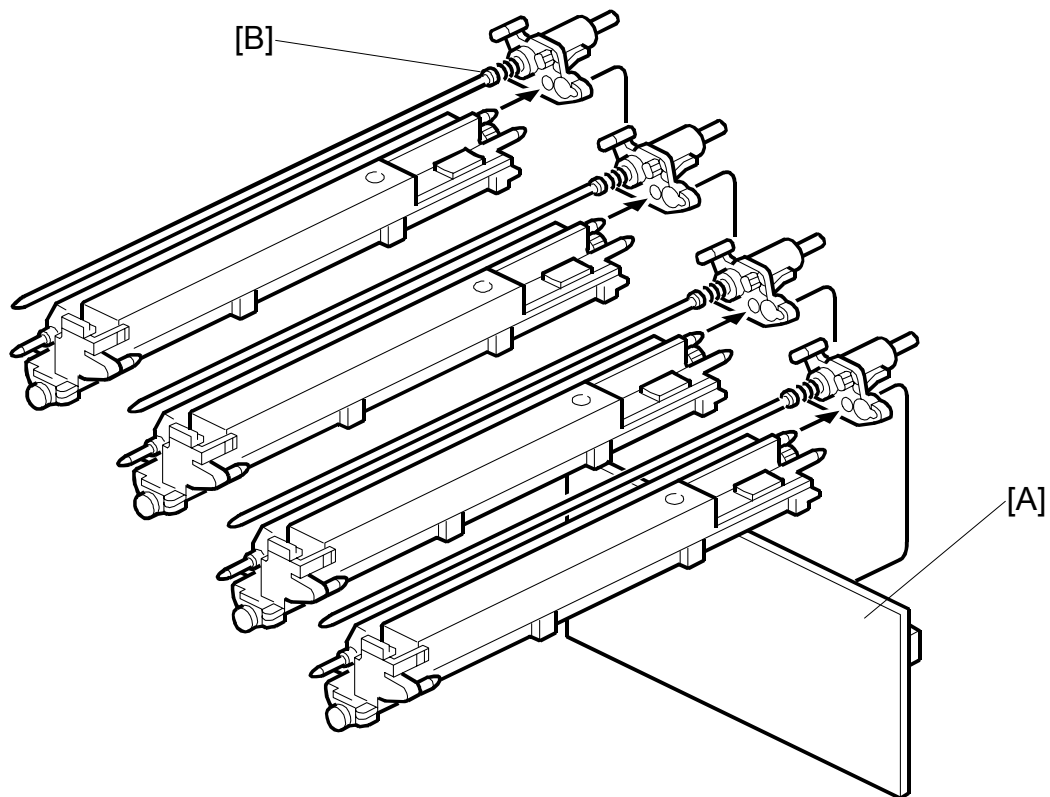

G130D535.WMF

The sub PSU [A] supplies development bias to the development roller via the receptacle [B] at the rear of each development unit.

There is a dc bias voltage.

The machine automatically controls the dc bias, if automatic process control is enabled (i.e., if SP3-125-001 is set to "ON"). However, if process control is switched off, (i.e., if SP3-125-001 is set to "OFF"), the dc bias is the value stored in SP2-201-001 to 009 (do not adjust in the field unless advised to do so).

6.5.5 TONER SUPPLY MECHANISM

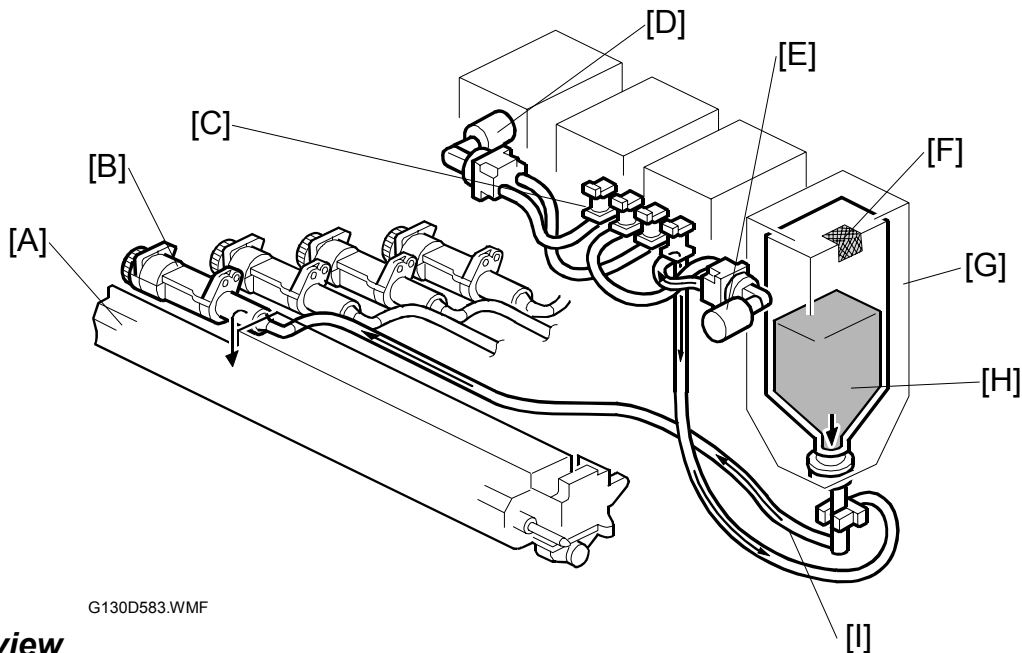

Overview

The air transport system agitates the toner [H] in the toner cartridges [G]. Toner is transported to the development unit [A] by the toner attraction pump [B] (each cartridge has a separate pump). This provides a more stable way to transport fine powder than previous methods.

Toner Agitation and Attraction

The rear air pump [D] supplies air to the yellow and magenta toner cartridges. The front air pump [E] supplies air to the black and cyan toner cartridges. Air agitates all the toner in each cartridge. The pumps and four valves [C] control the airflow. Mixed with air, the toner passes part of the way along the transport tube [I] towards the toner attraction pump. This pump draws the toner the rest of the way (● Toner Transport).

The air pump turns on to supply air to the toner cartridges for one second under the following conditions:

- During normal operation (when the “on” time for a toner supply clutch reaches a certain value).
- When forced toner supply (SP2-207) is done
- When forced toner density adjustment (SP3-126-002) is done
- At toner end recovery
- Developer initialization

The filter [F] on the inner package of the toner cartridge ensures that the internal pressure does not become too high.

Air Flow and Toner Flow

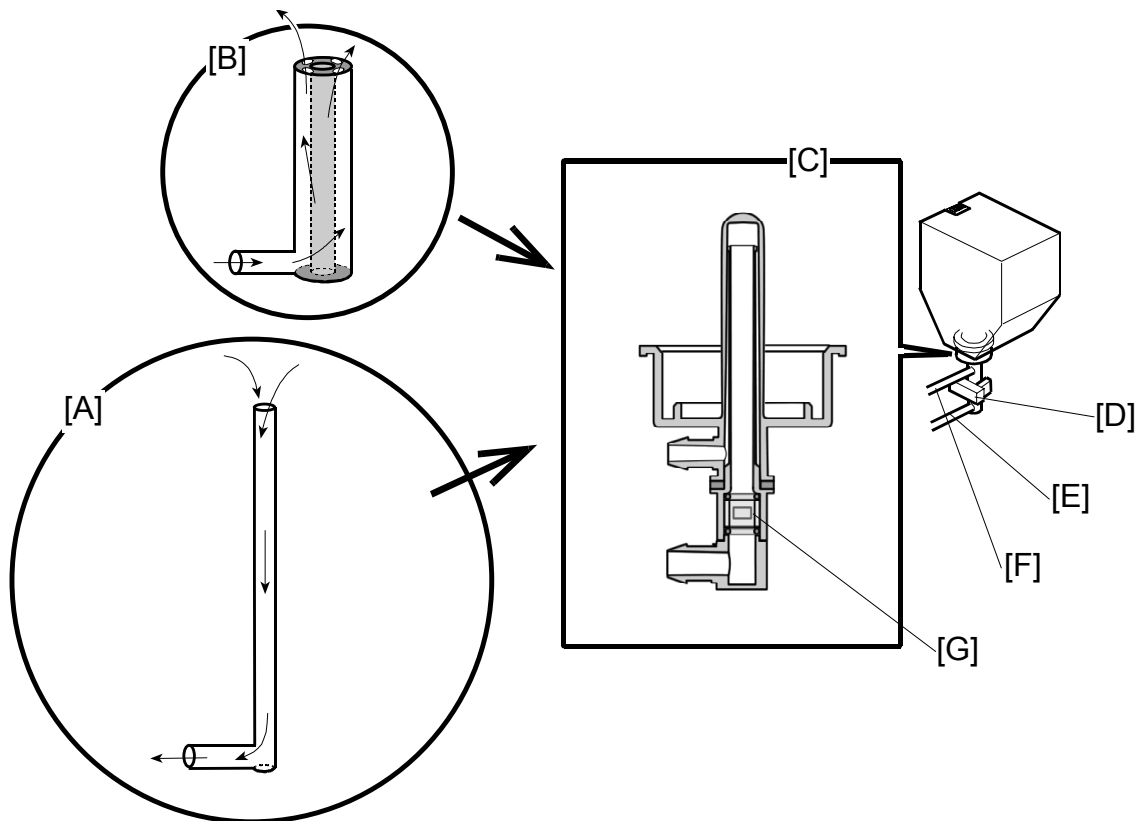

G130D536.WMF

The air tube [F] and the toner tube [E] are connected to the joint [C] at the bottom of the toner cartridge holder. This joint contains an inner pipe [A] and an outer pipe [B]. These two pipes are L-shaped. The inner pipe goes through the outer pipe. The inner pipe is longer than the outer pipe.

The toner goes through the inner pipe [A], and reaches the toner tube [E] at the bottom end of the pipe. The toner passes the sensor windows [G] on its way to the toner tube. The windows are transparent and are at the front side and the rear side of the pipe. The light emitted from the toner end sensor [D] goes through this area if there is no toner in the pipe.

The airflow generated by the air pump goes through the outer pipe [B], and comes out of the four openings at the top end.

Toner Near End Detection

Toner end sensors [D] detect toner near end conditions (➔ 6.2.6).

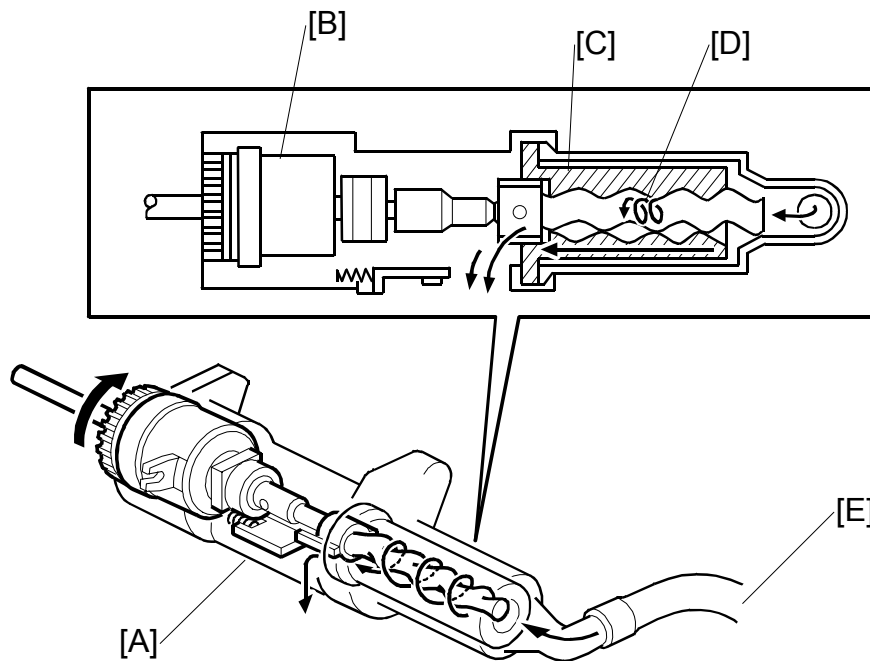
Toner Transport

G130D537.WMF

Each toner attraction pump has the same mechanism. The pump (toner attraction pump) [A], has the following components:

- Toner supply clutch [B]
- Rubber tube [C]
- Rotor [D]

The above components attract the toner in the toner transport tube [E] toward the development unit.

The toner supply clutch drives the rotor, which draws the toner in from the cartridge and passes it to the development unit. When supplying toner, the clutch turns on and off as many times as necessary to supply the necessary amount of toner. The amount of toner depends on the results of toner supply control.

Motor drive comes from the development drive motors.

Shutter Mechanism

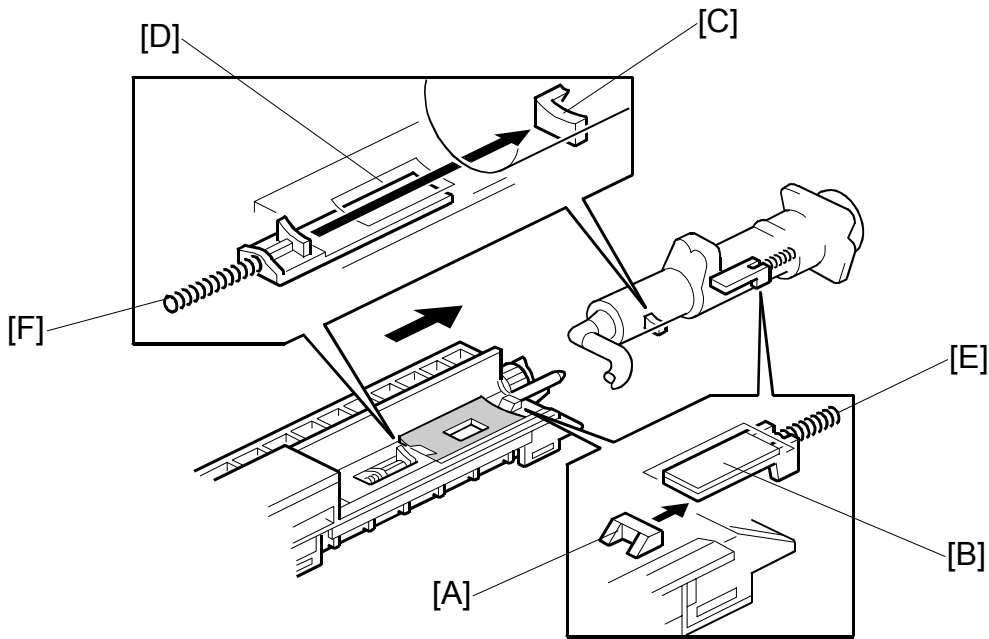

G130D538.WMF

The development unit and toner attraction pump each have a shutter mechanism. The protrusion [A] on the development unit opens the shutter [B] in the pump when the development unit is placed in the machine. At the same time the protrusion [C] on the pump opens the shutter [D] in the development unit. When both shutters are open, toner can enter the development unit from the toner attraction pump.

The shutter spring [E and F] pulls and closes the shutter when the development unit is removed.

6.5.6 TONER CARTRIDGE DETECTION

The memory chip [A] on each toner cartridge stores the total “on” time of the toner supply clutch. This is used to calculate the amount of toner remaining in the toner cartridge. The chip is also used to detect whether the cartridge is installed (if the cartridge is not installed, the machine does not detect a signal from the memory chip).

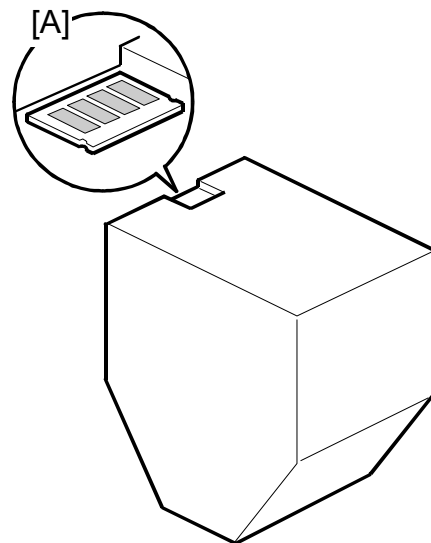

G130D539.WMF

Detailed Descriptions

6.6 PAPER FEED

6.6.1 OVERVIEW

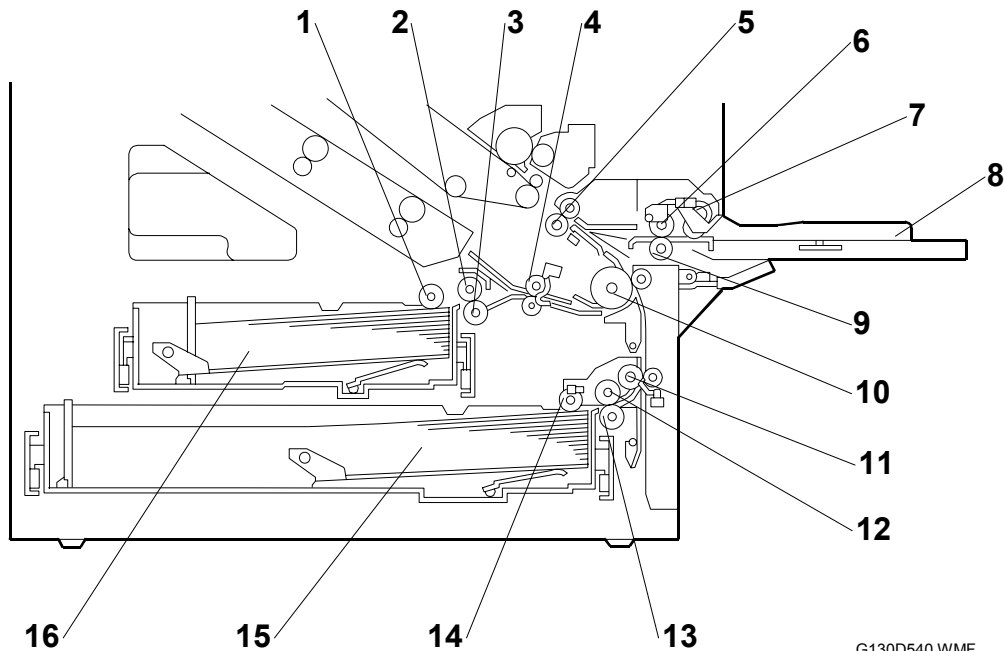

G130D540.WMF

- | | |
|----------------------------------|-------------------------------------|
| 1. Pick-up roller - tray 1 | 9. Separation roller - By-pass feed |
| 2. Feed roller - tray 1 | 10. Transport roller |
| 3. Separation roller - tray 1 | 11. Vertical transport roller |
| 4. Relay roller | 12. Feed roller - tray 2 |
| 5. Registration roller | 13. Separation roller - tray 2 |
| 6. Feed roller - By-pass feed | 14. Pick-up roller - tray 2 |
| 7. Pick-up roller - By-pass feed | 15. Paper tray 2 |
| 8. By-pass feed table | 16. Paper tray 1 |

There are two paper trays (500 sheets each), and a by-pass feed table (100 sheets).

The paper feed mechanism uses an FRR system.

Tray 1 can hold A4 or 8½" x 11" only. Tray 2 can hold a range of sizes.

6.6.2 DRIVE – TRAY 1, TRAY 2, AND BY-PASS TRAY

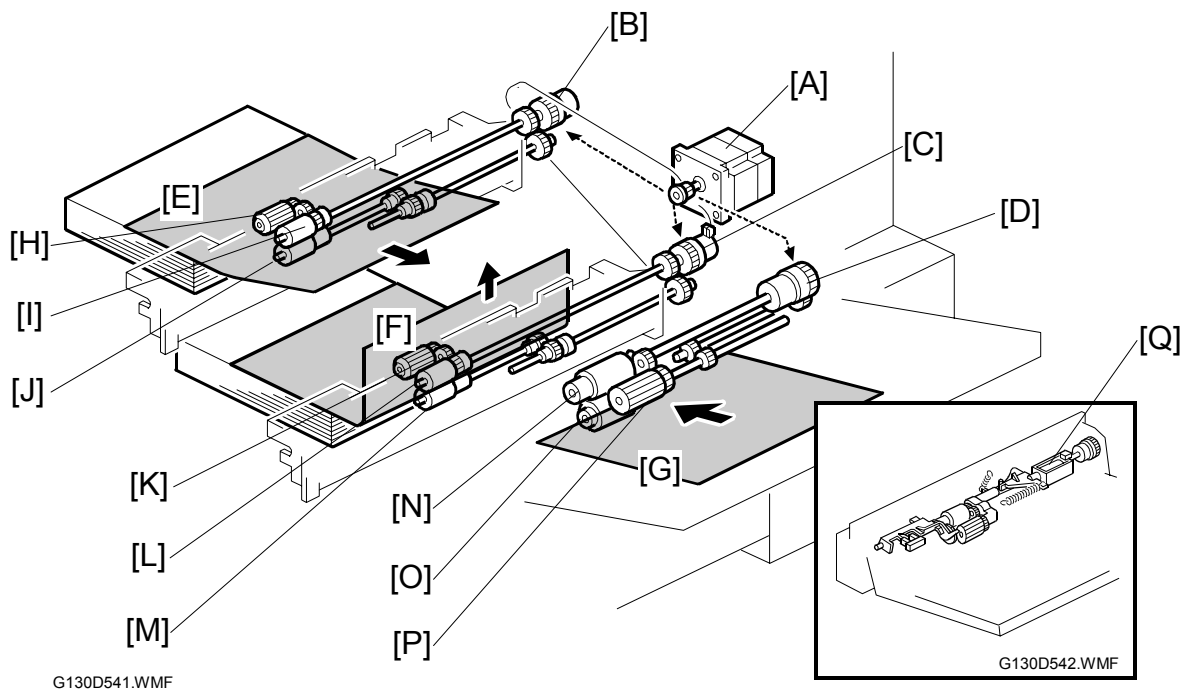

The paper feed motor [A] drives the pick-up and feed mechanisms in tray 1 [E], tray 2 [F], and the by-pass tray [G]. It uses clutches and complex trains of gears (the locations of the gear trains are indicated by dotted lines in the above diagram) to do this.

When tray 1 and tray 2 are inside the machine, their pick-up rollers [H][K] are always in contact with each top sheet of the paper stack. However, the pick-up roller [P] of the by-pass tray stays away until the by-pass pick-up solenoid [Q] turns on. When the paper feed clutch [B][C][D] turns on, the pick-up, feed [I][L][N], and separation [J][M][O] rollers start rotating to feed the paper. The paper feed clutch stays on until shortly after the registration sensor activates.

6.6.3 PAPER LIFT – TRAYS 1 & 2

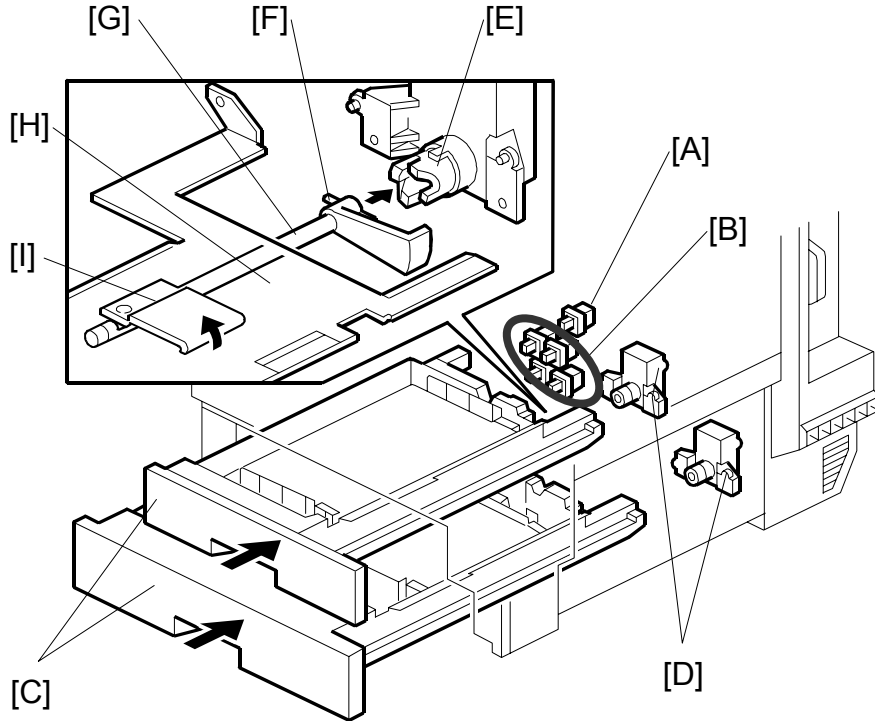

G130D543.WMF

The tray 1 set switch [A] and tray 2-paper size switches [B] detect when the paper trays [C] are placed in the machine. When the machine detects that a tray has been placed in the machine, the tray lift motor [D] rotates and the coupling gear [E] on the tray lift motor engages the pin [F] on the lift arm shaft [G]. Then the tray lift arm [I] lifts the tray bottom plate [H] until the paper lift sensor for the tray detects that the top of the stack is at the paper feed position.

6.6.4 PAPER SIZE DETECTION – TRAYS 1 & 2

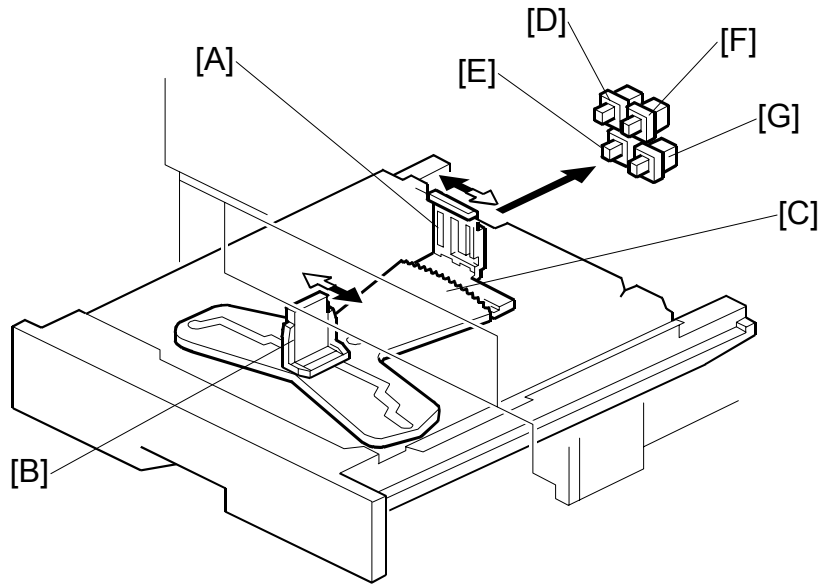

G130D544.WMF

There is no size switch for tray 1. The paper size is fixed at either A4 or 8 1/2" x 11". You can change this with SP1-902-1.

For tray 2, four paper size switches, working in combination, detect the paper size as shown in the table below. The actuators are on the side plate [A]. The side plate is moved by the end plate [B] through a cam [C].

1: Pushed

Models		Switch Location			
North America	Europe/Asia	1 [D]	2 [E]	3 [F]	4 [G]
11" x 17" SEF	11" x 17" SEF	0	1	0	0
A3 SEF	A3 SEF	1	0	1	0
8 1/2" x 14" SEF *1	B4 SEF *1	1	1	0	1
8 1/2" x 11" SEF *2	A4 SEF *2	0	1	1	0
11" x 8 1/2" LEF *3	11" x 8 1/2" LEF *3	1	0	1	1
A4 LEF	A4 LEF	0	1	0	1
B5 LEF	B5 LEF	0	0	1	0
A5 LEF	A5 LEF	0	0	0	1

Detailed Descriptions

NOTE:

*1: The machine detects either 8 1/2" x 14" SEF or B4 SEF, depending on the setting of SP 1-902-2

*2: The machine detects either 8 1/2" x 11" SEF or A4 SEF, depending on the setting of SP 1-902-3

*3: The machine detects either 11" x 8 1/2" LEF or B5 SEF, depending on the setting of SP 1-902-4

The machine disables paper feed from a tray if the paper size cannot be detected (if the paper size actuator is broken or no tray is installed).

6.6.5 PAPER HEIGHT DETECTION – TRAYS 1 & 2

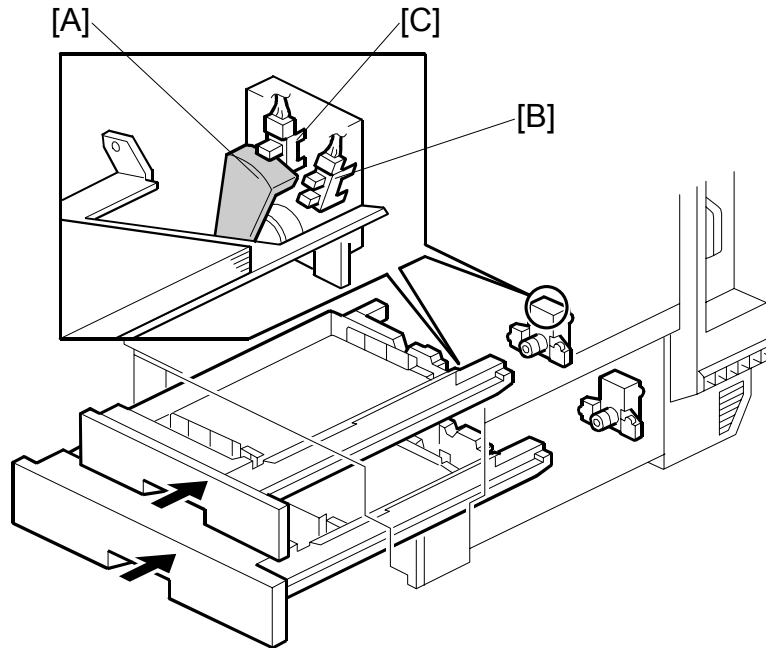

G130D545.WMF

Two paper height sensors, working in combination, detect the amount of paper in the tray.

When the amount of paper decreases, the bottom plate pressure lever moves up and the actuator [A] (on the pressure lever drive shaft) rotates.

Remaining paper	Paper height sensor 2 [B]	Paper height sensor 1 [C]
Full	OFF	OFF
Nearly full	ON	OFF
Near end	ON	ON
Almost empty	OFF	ON

OFF: No actuator

6.6.6 PAPER END DETECTION – TRAYS 1 & 2

The paper stack raises the paper end feeler and the paper end sensor deactivates if there is some paper in the paper tray.

When the paper tray runs out of paper, the paper end feeler drops into the cutout in the tray bottom plate. At this time, the paper end sensor is activated.

6.6.7 REGISTRATION

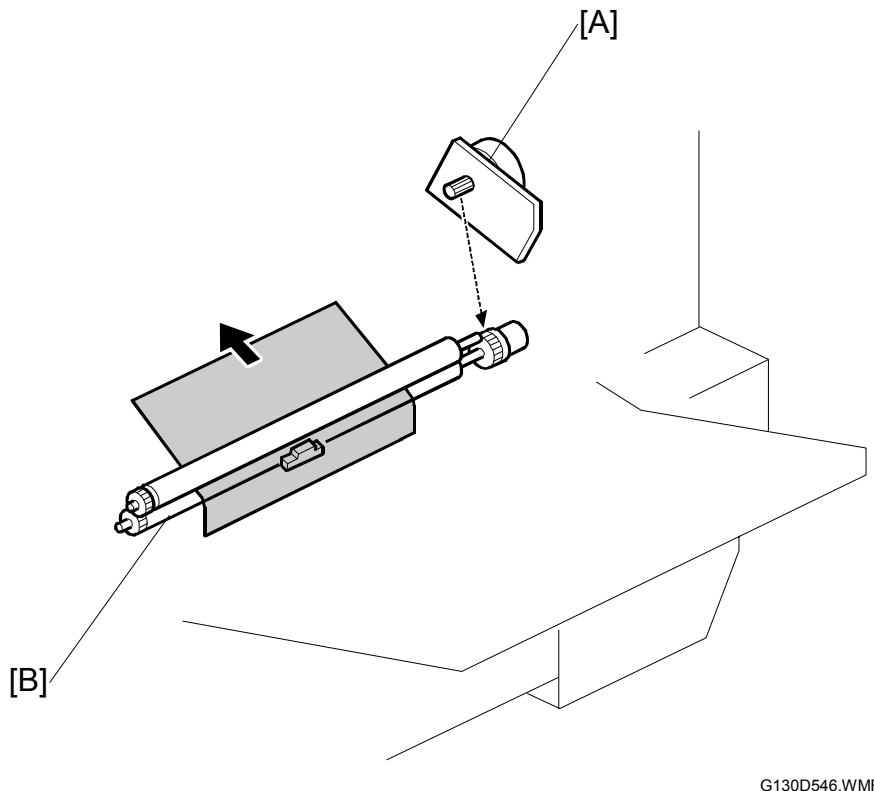

G130D546.WMF

The development drive motor - CMY [A] drives the registration roller [B] with a clutch and a complex train of gears (the location of the gear train is indicated by dotted lines in the above diagram).

The machine makes a paper buckle at the registration roller to correct paper skew. You can adjust the paper buckle with SP1-003-1 to -8.

6.6.8 PAPER FEED LINE SPEED

This machine has three process line speeds (for feed from registration roller to fusing unit). The line speeds depend on the mode, selected resolution, and model.

Mode	Resolution (dpi)	Line speed (mm/s)	Print speed (ppm)
B/W	600 x 600	162	G130: 32
	1,200 x 600		G131: 35
	1,200 x 1,200	81	17
Color	600 x 600	G130: 125	G130: 28
	1,200 x 600	G131: 162	G131: 35
	1,200 x 1,200	81	17
OHP/Thick	600 x 600	81	14
	1,200 x 600		
	1,200 x 1,200		

The machine changes the line speed if there is a page with color in the middle of the job during a monochrome print job. However, it will not change the line speed if there is a monochrome page in the middle of a color print job.

	Line speed (mm/s)
Paper feed from tray to registration roller	230
Fusing, paper exit to standard tray, and mailbox	A bit slower than "Process line speed"
Duplex invert and feed	370
Finisher	450

6.6.9 GRIP ROLLER RELEASE MECHANISM

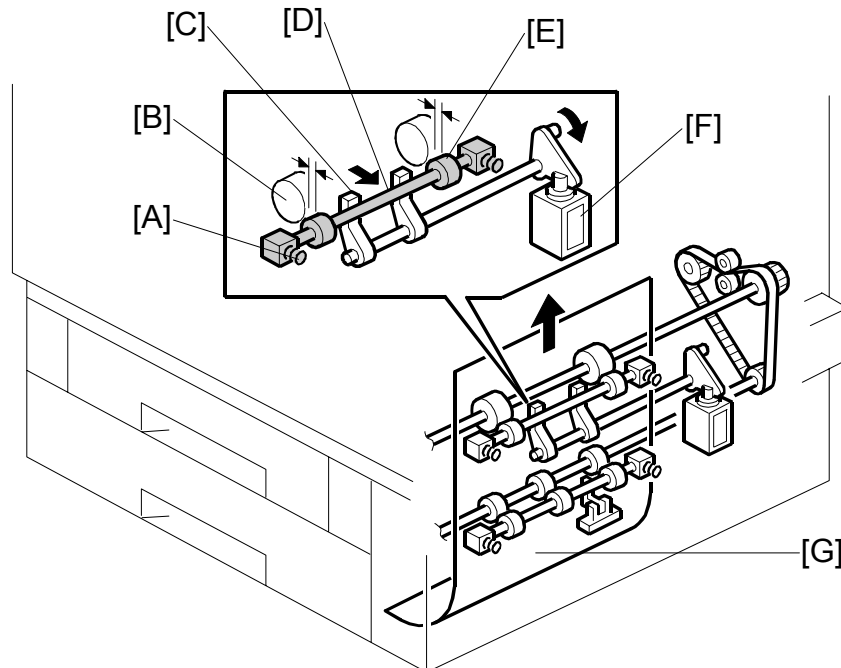

G130D547.WMF

The grip roller release mechanism reduces the pressure of the grip roller [E].

The grip roller transports a sheet of paper to the transfer unit. When the transfer unit starts to feed the leading edge of the paper [G], the trailing edge has still not reached the grip roller. Paper gets handled by the transfer unit and the grip roller at the same time. If the handling speeds are not the same, this may skew the paper. Longer paper sizes are more affected by the speed difference than shorter sizes. From the viewpoint of image crispness, multi-color images are more easily affected than mono-color images.

To solve this possible problem, the grip roller release mechanism is activated under the following conditions:

- 1) B4 paper or longer is being fed.
- 2) The machine is operating in the full-color mode.
- 3) The leading edge of the paper has been fed in the transfer unit.

The spring [A] always presses the grip roller against the transport roller [B]. When the above conditions are met, the solenoid [F] turns on. Then the lever [C] pushes the grip roller shaft [D], and the grip roller moves away from the paper.

6.7 IMAGE TRANSFER AND PAPER SEPARATION

6.7.1 OVERVIEW

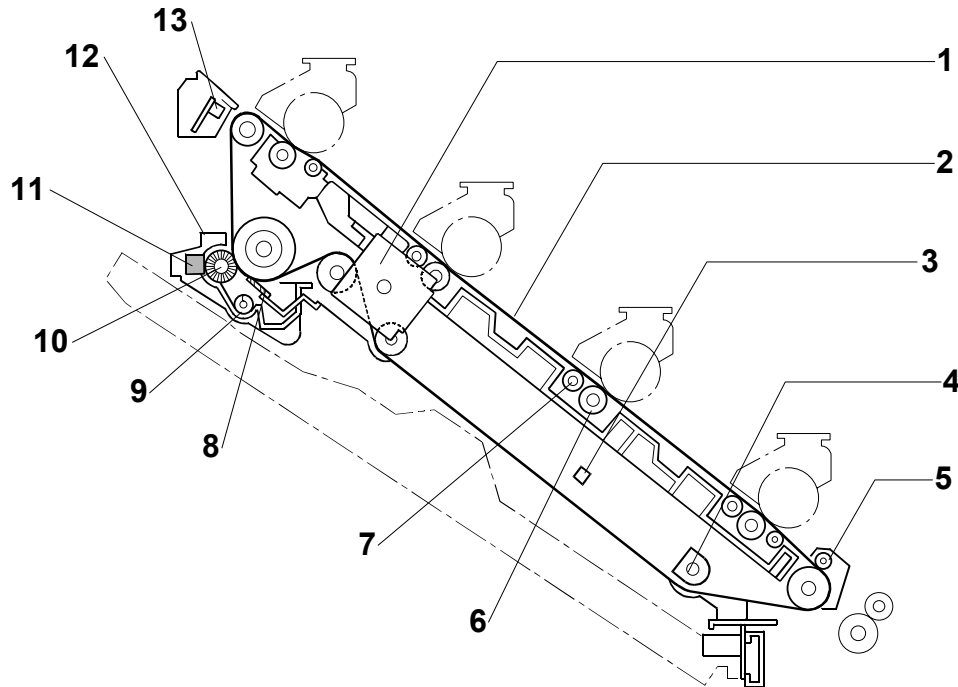

- | | |
|------------------------------|---------------------------|
| 1. Transfer unit drive motor | 7. Back-up roller |
| 2. Transfer belt | 8. Cleaning blade |
| 3. Transfer belt mark sensor | 9. Toner collection auger |
| 4. Rotation encoder | 10. Cleaning brush |
| 5. Paper attraction roller | 11. Lubricant bar |
| 6. Transfer roller | 12. Cleaning unit |
| | 13. ID sensor |

Paper is fed to the transfer belt before image transfer begins. The paper attraction roller charges the paper to ensure that the paper is attracted to the belt.

The magenta, cyan, yellow, and black color images transfer to the paper while the transfer belt feeds the paper past the drums towards the fusing unit. A positive charge is applied to the paper under the transfer belt, opposite each drum, to transfer the toner from the drums onto the paper. The back-up roller makes sure that the contact area between the drum and belt is sufficient.

The cleaning unit in the transfer unit cleans the belt surface with the cleaning blade and brush. The waste toner collected from the belt is transported to the waste toner bottle.

There are three ID sensors (front, center, and rear). Only the center ID sensor detects the image density of the patterns generated on the transfer belt for process control. The other function of the ID sensors is for automatic line position adjustment. All ID sensors are used for this.

6.7.2 TRANSFER BELT DRIVE

Drive Motor

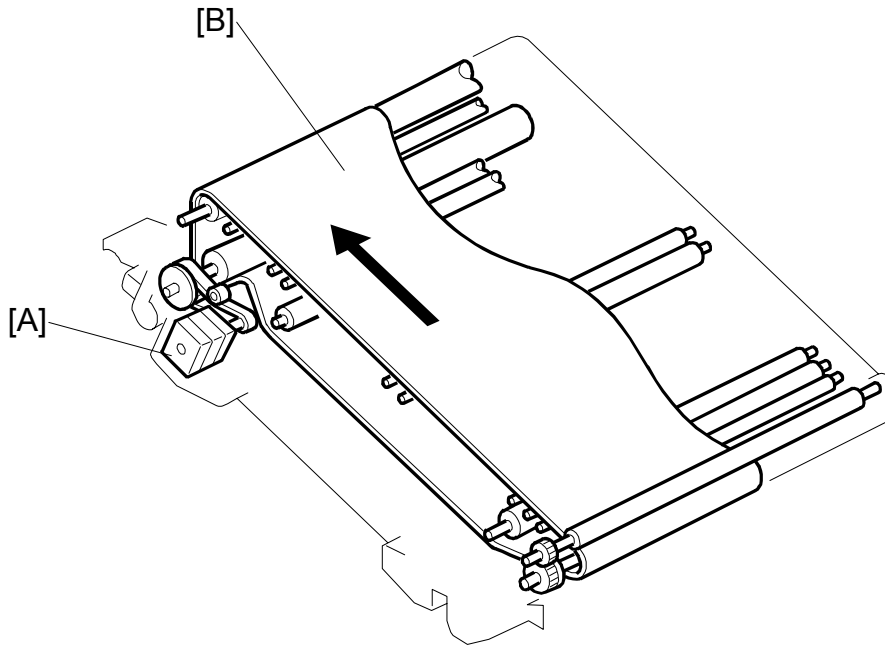

G130D549.WMF

The transfer unit drive motor [A] drives the transfer belt [B] and the cleaning unit via the timing belt and gears. The speed of transfer belt drive depends on the process line speed.

Detailed
Descriptions

Transfer belt speed control

This machine uses two devices (Rotation encoder and transfer belt mark sensor) to control the transfer belt speed.

Rotation Encoder

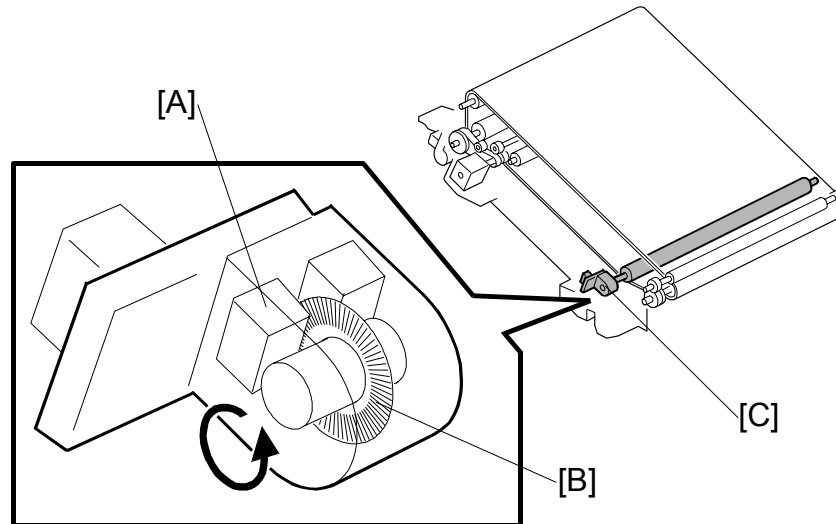

G130D550.WMF

An encoder [C] is on one of the rollers. This encoder checks the rotation speed of the transfer belt. The controller analyzes the signals from the encoder. Then it adjusts the rotation speed of the transfer belt.

The encoder contains a disk that has 300 notches on its surface [B]. These notches are read by the sensor [A]. The controller counts the number of notches that the sensor has read in the unit of time. If the sensor has read an unusually large number of notches or an unusually small number of notches, the controller ignores such unusual signals. Therefore, incorrect reading does not affect the rotation speed.

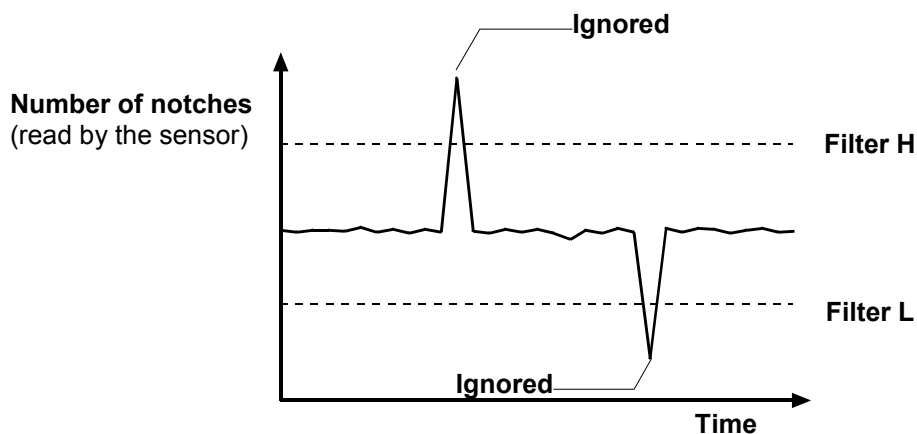

G130D584.WMF

Filter H: The number of notches read by the sensor when the rotation speed of the transfer belt is at its highest possible value.

Filter L: The number of notches read by the sensor when the rotation speed of the transfer belt is at its lowest possible value.

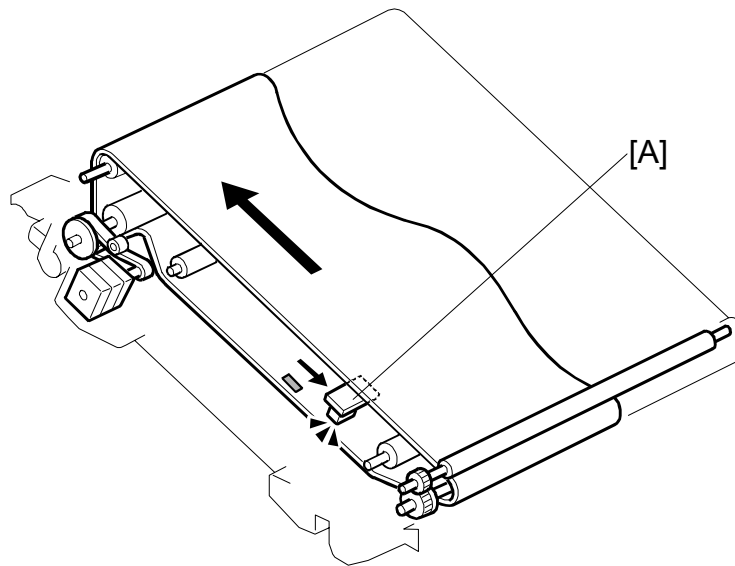
Transfer belt mark sensor

G130D551.WMF

There is the transfer belt mark sensor [A].

Transfer belt mark sensor monitors the transfer belt home position. The machine uses this information to adjust the speed of the belt to account for the belt regularity.

This control method is called "Dancing Control" in the SP5-995. You must execute SP5-995-025 and -027 after replacing the transfer belt unit or transfer belt.

6.7.3 TRANSFER CURRENT

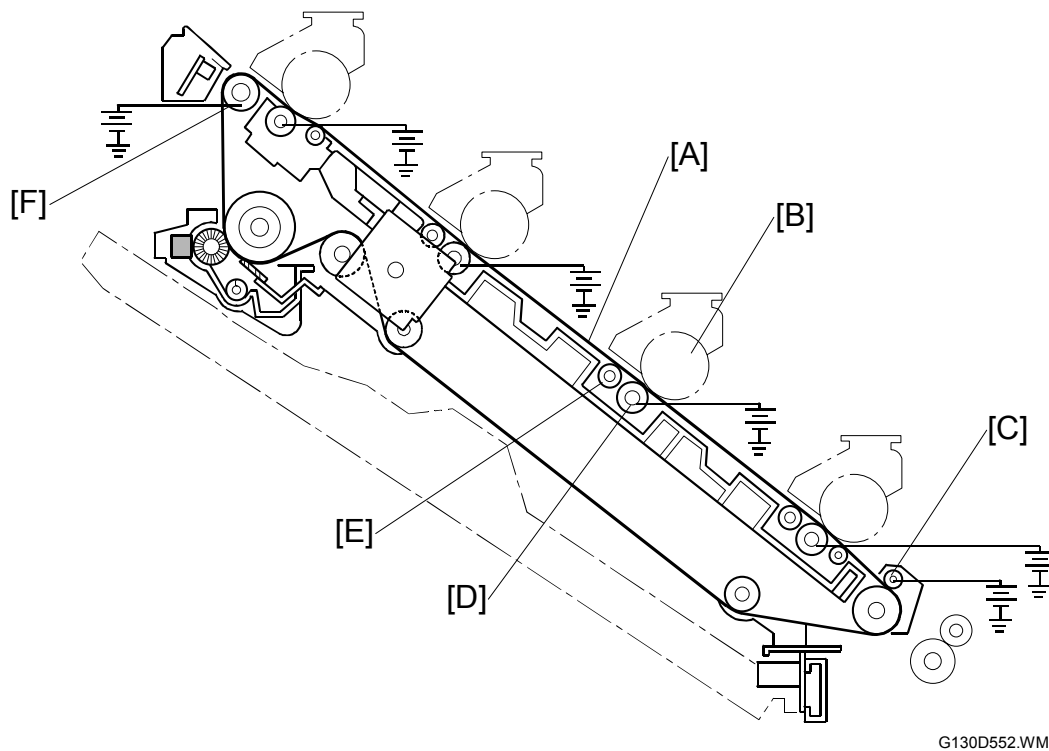

The transfer roller [D] applies a current to transfer the toner to the paper on the transfer belt [A]. The high voltage supply board supplies current to the transfer roller and the paper attraction roller [C].

These currents are automatically corrected for paper size, temperature (measured by the thermistor on the right side of the laser optics housing unit), and humidity (measured by the humidity sensor).

The following adjustments are shown below:

- You can adjust the transfer roller current for each printing mode (color or B/W, resolution, paper type) with SP2-301-1 to -160. The by-pass tray settings are used when the duplex unit has not been installed and the user is making duplex prints manually from the by-pass tray. There is a correction for narrow-width paper with SP2-309-5 to -17.
- You can adjust the current for paper attraction with SP2-801-1 to -65.

The back-up roller [E] makes a wider contact area between the drum [B] and the belt. The transfer exit roller [F] is charged to 2 kV. The roller prevents the toner from being scattered while the paper is leaving the transfer unit.

The other rollers are grounded to neutralize the belt surface.

6.7.4 TRANSFER BELT CLEANING

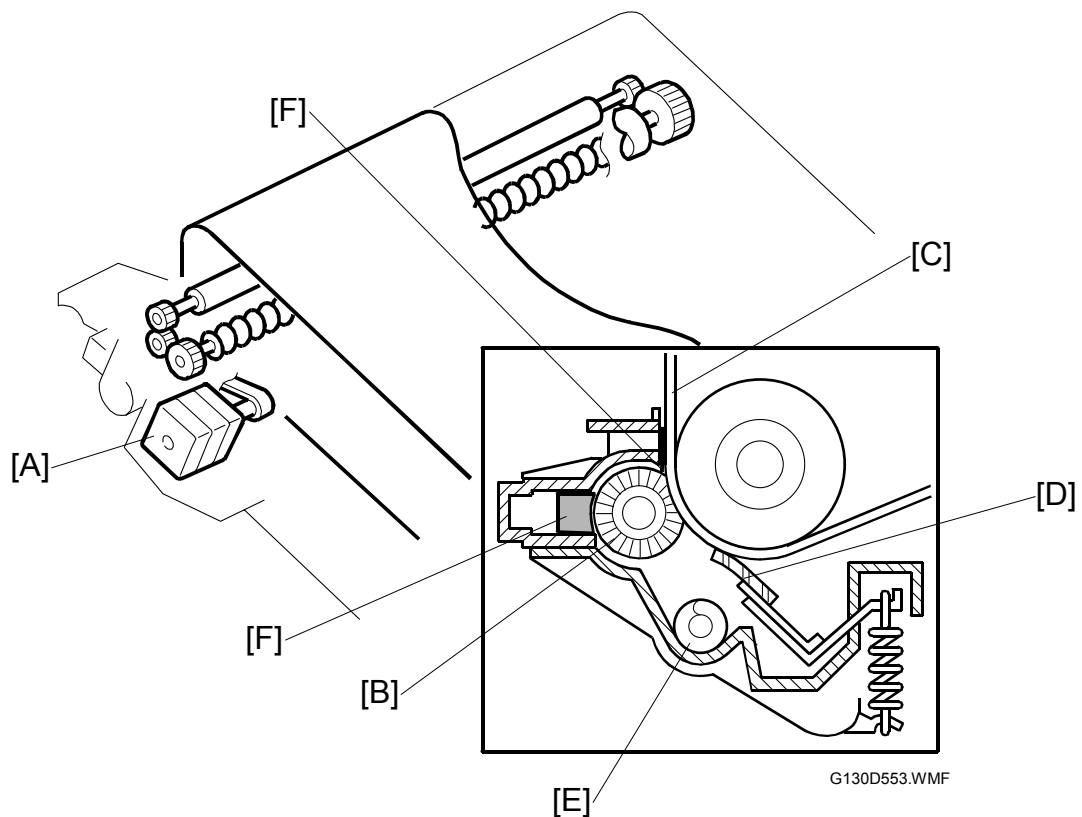

The transfer belt-cleaning unit removes toner (during printing) and the ID sensor patterns (during process control or automatic line position adjustment) on the belt. Belt cleaning is completed while the transfer belt makes one rotation. The transfer unit drive motor [A] drives the unit.

The cleaning brush [B] always contacts the transfer belt [C], and removes waste toner from the belt. The lubricant bar [F] is on the cleaning brush. The cleaning brush rubs against the lubricant bar and lubricates the belt surface. The cleaning blade [D] in the cleaning unit scrapes toner and excess lubricant off the transfer belt. Then the toner collection auger [E] transports the toner towards the waste toner collection duct.

The scraper [F] does not let the waste toner stick to the cleaning brush.

6.7.5 TRANSFER BELT CONTACT

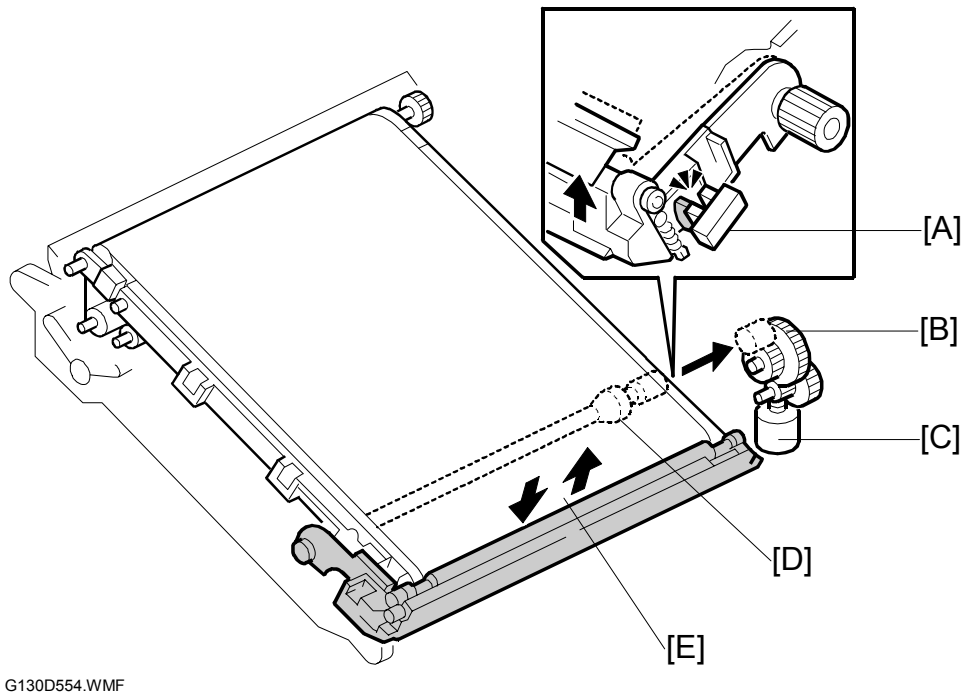

G130D554.VWMF

Mechanism

The transfer belt contact and release mechanism increases the lifetime of the transfer belt and drums.

The drum for black always contacts the belt. However, the transfer belt moves away from the other drums during monochrome printing.

In the standby mode, the transfer belt contacts only the black drum. The transfer belt moves away from the black drum when you turn the release lever counterclockwise.

When the machine prints a color page, the machine waits until the previous page has gone through the transfer unit. Then the transfer belt contact motor [C] turns on and a cam [D] moves the lower end [E] of the transfer belt upward, so that it contacts the other three drums.

The machine does not release the transfer belt from the color drums during the job, even if a monochrome page comes again. This is because the total printing speed reduces if the transfer belt changes position.

The belt moves away from the color drums if the job is interrupted by any error except a power failure.

NOTE: If a power failure occurs when the transfer belt is in contact with the drum, the belt stays in this position. To release the belt, turn the main power off and on.

Transfer Belt Sensor

The transfer belt sensor [A] operates as the detection sensor during machine initialization, and also as the position sensor during machine operations.

Before machine initialization, the lower end of the transfer belt is in the home position. When initialization starts, the transfer belt contact motor lifts the lower end until the actuator has passed the sensor. Then it lowers it to its home position. This action actuates the sensor in a certain pattern.

The table lists the sensor actuation patterns.

Machine status		Sensor pattern
Initialization		On → Off → On → Off → On
Operation	Standby (Default)	On
	B/W printing	On
	Color Printing	Off

On: The actuator is out of the sensor.

Off: The actuator is interrupting the sensor.

6.7.6 ACS (AUTO COLOR SENSING) MODE

ACS: On

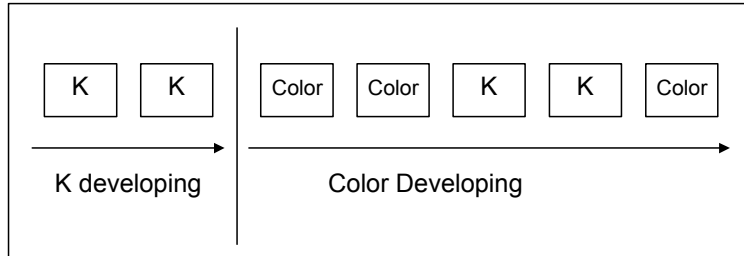

ACS: Off



G130D964.WMF

The machine can print in the color or monochrome mode (selected with the printer driver). In color mode, ACS can be switched on or off with a user tool (default: on).

If ACS is on, the transfer belt stays in the default position (against the K drum only) until a page with color data on it shows. The transfer belt then moves against all four drums and stays there until the end of the job, even if some K only pages appear.

If ACS is off and the color mode is selected, all data is printed with the transfer belt positioned against all four drums. The belt does not move even if a K only page appears, even if it is at the start of the job.

6.8 FUSING

6.8.1 OVERVIEW

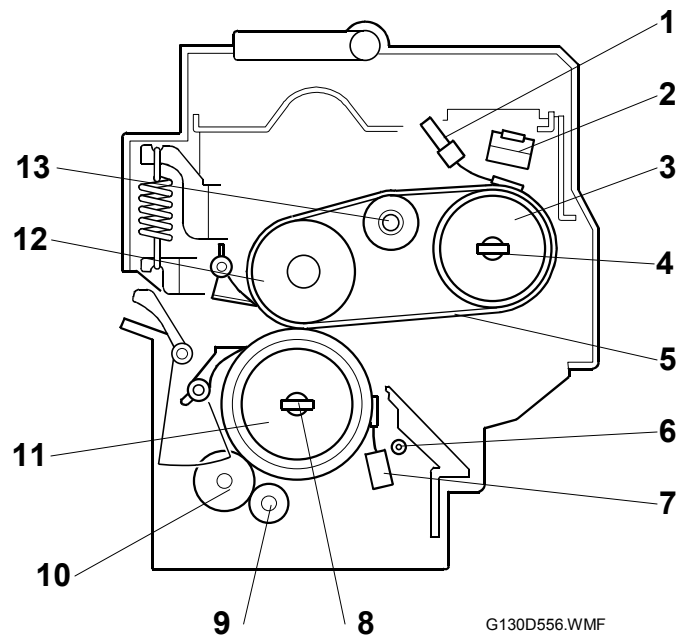

- | | |
|--------------------------------|--------------------------------|
| 1. Heating roller thermistor | 8. Pressure roller fusing lamp |
| 2. Heating roller thermostat | 9. Oil supply roller |
| 3. Heating roller | 10. Cleaning roller |
| 4. Heating roller fusing lamp | 11. Pressure roller |
| 5. Fusing belt | 12. Hot roller |
| 6. Pressure roller thermo fuse | 13. Tension roller |
| 7. Pressure roller thermistor | |

- A belt fusing system is used. This has a faster warm-up time than a conventional hot and pressure roller system.
- The heating roller is made of aluminum to increase the temperature of the fusing belt quickly.
- The hot roller is made of sponge, which flattens slightly, also increasing the fusing nip. This roller does not contain a fusing lamp.
- Each of the heating and pressure rollers has a fusing lamp.
 - NA: 770W for the heating roller. 350W for the pressure roller
 - EU: 700W for the heating roller. 325W for the pressure roller
- The heating roller thermistor and pressure roller thermistor control the temperature of these lamps.
- Temperature is normally controlled by turning the fusing lamps on and off. SP1-104-1 is used to change between on/off control and phase control
- The oil supply roller supplies a small amount of oil to the pressure roller through the cleaning roller. Oil does not need to be supplied to the oil supply roller because it contains oil and the amount of oil supplied to the pressure roller is small.

6.8.2 FUSING UNIT DRIVE

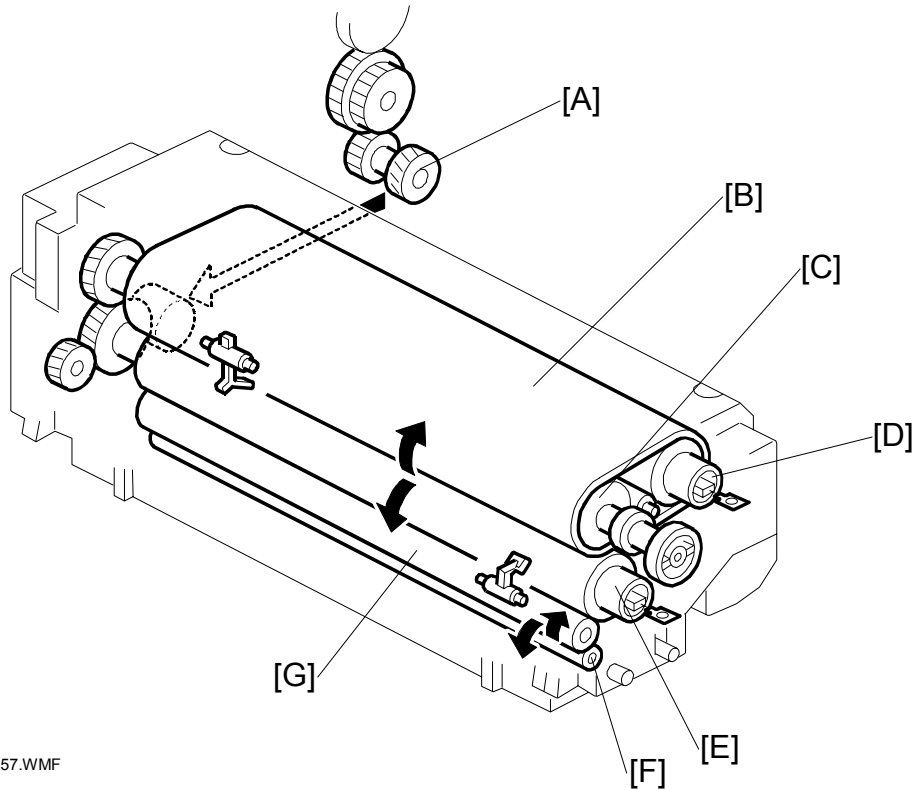

G130D557.WMF

Belt and Rollers

Development drive motor-K drives the pressure roller [E] and the hot roller [D] through the gear train. The heating roller [C] is driven by the pressure with the fusing belt [B]. The cleaning roller [G] and oil supply roller [F] are driven by the friction with the pressure roller.

Fusing Clutch

The fusing clutch [A] turns off and cuts the drive power when the fusing unit does not operate. This mechanism prevents wear on the belt and rollers.

NOTE: The fusing clutch turns off when images and patterns are created on the transfer belt during process control and line position adjustment.

6.8.3 FUSING TEMPERATURE CONTROL

Fusing Temperatures

When the main switch turns on, the CPU turns on the fusing lamp. The lamp stays on until the thermistor detects the standby temperature. Then the CPU raises the temperature to the printing temperature.

The fusing temperature for each mode is as follows.

Mode	Resolution (dpi)	Temperature of Heating Roller	Temperature of Pressure Roller	Note
Energy saver level 1		30°C	G130: 105°C G131: 110°C	
Standby mode		175°C	150°C	☛ NOTE: 1)
Color (simplex/duplex)	1,200 x 1,200	135°C	130°C	
	1,200 x 600 600 x 600	G130: 140°C G131: 160°C	G130: 130°C G131: 145°C	
Black and white (simplex/duplex)	1,200 x 1,200	135°C	130°C	
	1,200 x 600 600 x 600	160°C	145°C	
Middle thick color (simplex/duplex)	1,200 x 1,200	140°C	135°C	
	1,200 x 600 600 x 600	G130: 155°C G131: 175°C	G130: 140°C G131: 150°C	
Middle thick black and white (simplex/duplex)	1,200 x 1,200	140°C	135°C	
	1,200 x 600 600 x 600	175°C	150°C	
OHP	All	145°C	130°C	
Thick	All	155 °C	150 °C	

NOTE: 1) These are temperatures for standby mode when SP1-104-025 is set to the default setting. In addition, customers can adjust the temperatures for standby mode with UP mode.

The heating and pressure roller temperatures for fusing are stored in SP1-105-4 to -129.

When the machine is switched on, the fusing lamp temperatures increase to those specified by SP1-104-25.

The print ready temperature is slightly less than the fusing temperature. The difference is specified by SP1-105-1 and -2.

Temperature Corrections

The following SP modes are available to prevent excessive glossiness caused by fusing temperature overshoot:

- 1-913: Fusing temperature is reduced after this number of pages during the job.
- 1-914: This shows how much the temperature is reduced

If a job using OHP or thick paper starts while the fusing unit is still warm, the fusing temperature could be higher than the target for this type of paper. This can cause marks to show on the output. The following SP modes prevents this problem:

- 1-996-4, 5: These SPs specify a limit, above which printing will not start.

Overheat Protection

The CPU cuts power to the fusing lamp at the following times:

- The heating roller temperature becomes higher than 250°C for two seconds or more
- The pressure roller temperature becomes higher than 210°C for five seconds or more.

SC543 for the heating roller or SC553 for the pressure roller show for these conditions.

The following components are used if thermistor overheat protection fails.

- Two thermostats for the heating roller and two thermofuses for the pressure roller in series with the common ground line of the fusing lamp.
 - If one of the thermostat temperatures becomes higher than 234°C, it opens and cuts power from the fusing lamp.
If the other thermostat temperatures becomes higher than 235°C, it also opens and cuts power from the fusing lamp.
 - If either of the two thermofuses temperature becomes higher than 154°C, the thermofuse opens and cuts power from the fusing lamp.
NOTE: These thermofuses make a series circuit.

In either case, the machine stops operation.

6.8.4 NEW FUSING UNIT DETECTION

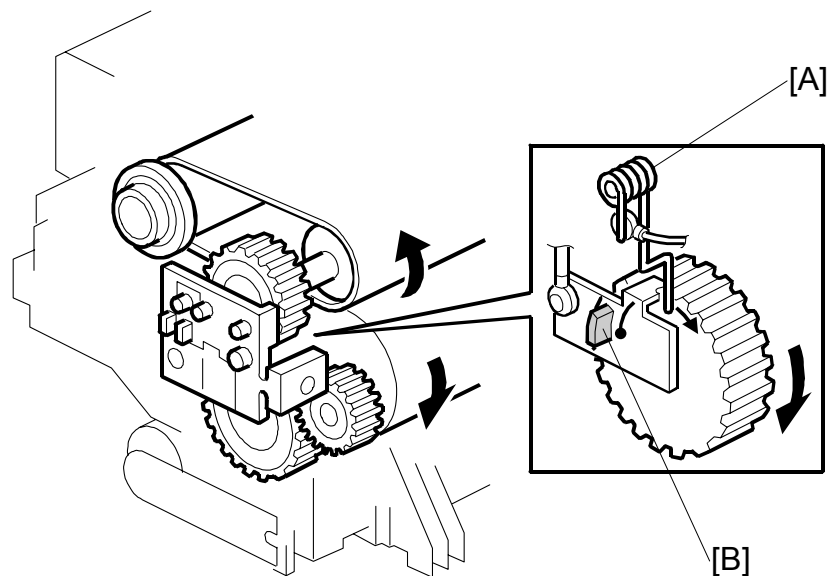

G130D965.WMF

The new fusing unit contains a spring [A] as part of a circuit connected to the BCU. After a new unit has been installed in the machine and the fusing pressure roller is driven for the first time, a pin [B] on the fusing pressure roller picks off the spring and the looped wire circuit opens.

When the power is turned on or the left cover is closed, the BCU checks whether the looped wire circuit is open or closed. If the fusing unit has just been replaced, the circuit is still closed, and the machine detects the new unit. It then automatically resets the counter for the unit.

The fusing unit's life is detected by counting the number of prints made. The machine indicates near-end 1,250 sheets (G130) or 1,750 (G131) before the life of the unit runs out. This timing can be changed with UP mode.

6.8.5 ENERGY SAVER MODES

When the machine is not being used, the energy saver feature reduces power consumption by switching off the fusing lamps. This machine has two energy saver modes.

Level 1 Energy Saver Mode

The default of the level 1 energy saver mode is "Off." If the user enables it, level 1 energy saver mode starts 30 seconds after the machine has completed a print. In this mode, the fusing lamps are intermittently turned on and off to keep the heating roller at 30°C and pressure roller at 105°C (G130) or 110°C (G131).

The machine leaves this mode when one of the following happens:

- Print command received from a PC
- Any cover opened and closed
- Any operation panel key pressed

Level 2 Energy Saver Mode

The level 2 energy saver mode starts after the machine has been idle for a certain time. This time is specified with UP mode as listed below. During the level 2 energy saver mode, both fusing lamps stay off.

- Off (energy saver mode never activates)
- 5 minutes
- 15 minutes
- 30 minutes
- 45 minutes
- 60 minutes (default)

When the machine is in this mode, the machine turns off +24 V, +12 V, and +5 V lines. However, only +5 VE lines, for the controller and GAPCI (voltage monitoring ASIC) on the BCU, are still active.

The machine leaves this energy saver mode when one of the following happens:

- Print command received from a PC
- Any operation panel key pressed

NOTE: The machine does not leave the level 2 energy saver mode when covers are opened and closed, because the CPU on the BCU is not active.

6.9 PAPER EXIT

6.9.1 OVERVIEW

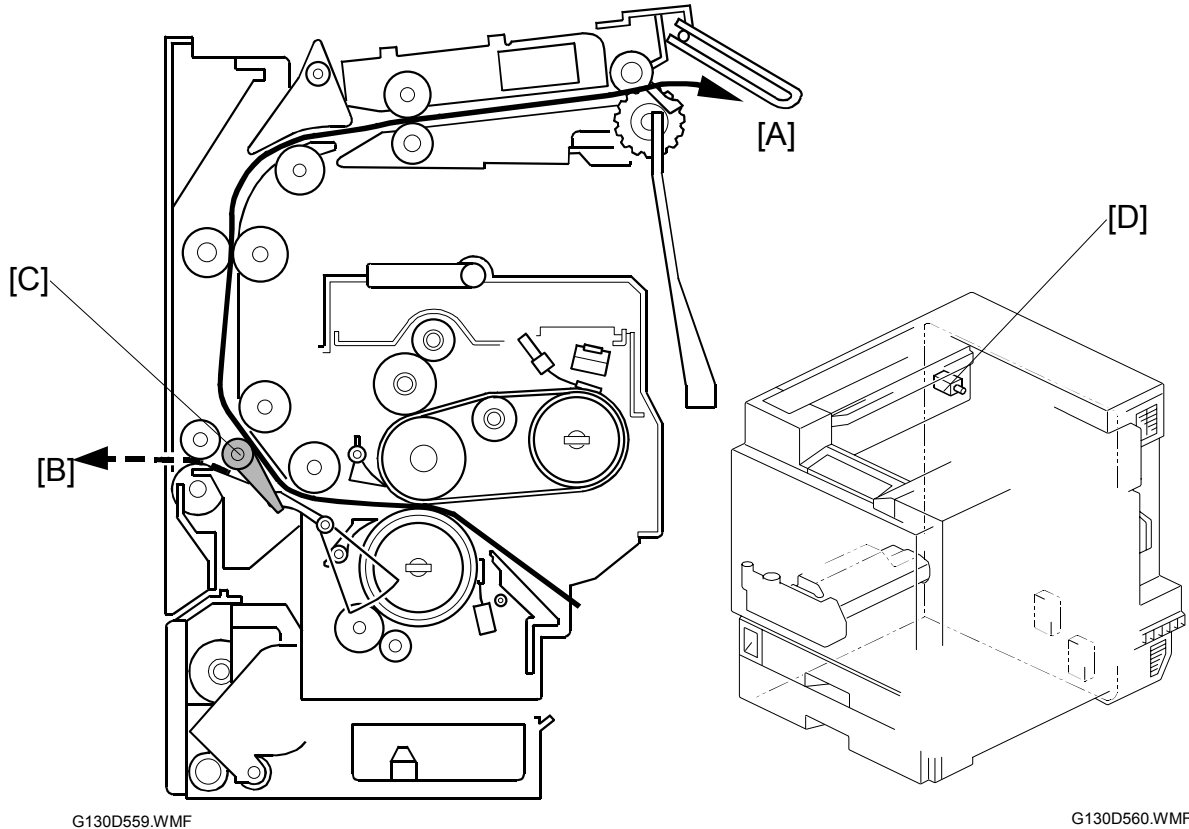

- [A]: To standard paper tray
 [B]: To external paper tray
 [C]: Junction gate
 [D]: Junction gate solenoid

Detailed
 Descriptions

After fusing, the junction gate feeds paper to the standard paper tray or the external paper tray. The junction gate solenoid [D] controls the junction gate as follows:

- To the standard paper tray: The junction gate solenoid is off (default)
- To the external paper tray: The junction gate solenoid is on.

Development drive motor-K drives the exit rollers.

6.9.2 PAPER OVERFLOW DETECTION

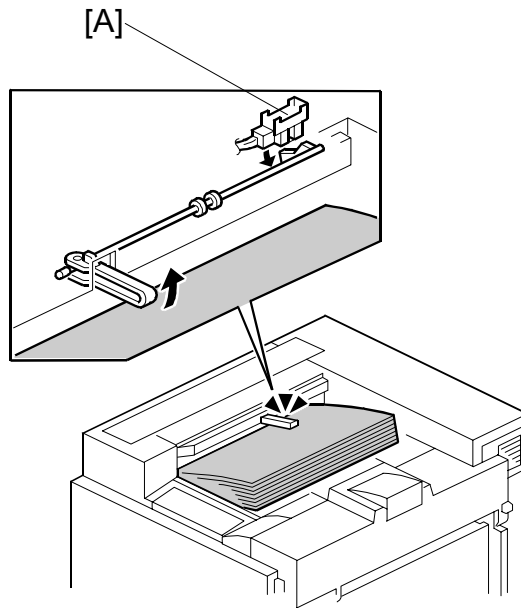

G130D561.WMF

When the paper overflow sensor [A] is activated, the machine detects that the paper stack height has exceeded a certain limit. At this time, printing stops.

6.10 DUPLEX UNIT

6.10.1 OVERVIEW

The duplex unit is standard for the G131 and optional for the G130.

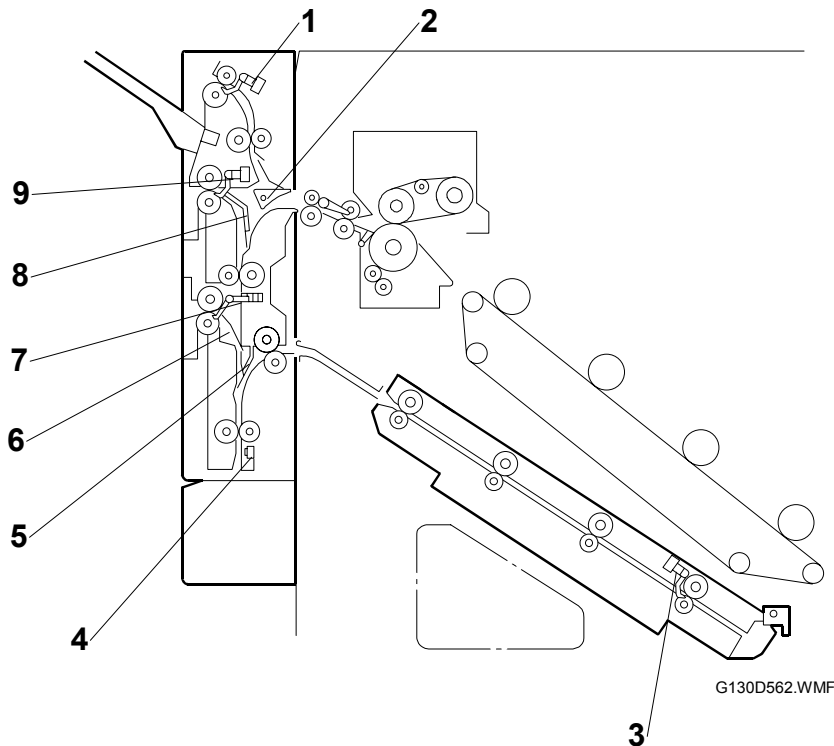

- | | |
|---------------------------|---------------------|
| 1. Exit sensor 1 | 6. Junction mylar 2 |
| 2. Junction gate | 7. Exit sensor 3 |
| 3. Duplex feed sensor | 8. Junction mylar 1 |
| 4. Duplex inverter sensor | 9. Exit sensor 2 |
| 5. Junction mylar 3 | |

- The second page (rear side) is printed first for duplex print jobs.
- To print on the second side, the duplex inverter unit (on the side of the machine) inverts the paper from the fusing unit and feeds it to the duplex feed unit (inside the machine).
- The duplex feed unit feeds the inverted paper back to the paper feed section.
- When both sides have been printed, the duplex inverter unit feeds the paper out to the finisher.
- If the mailbox or standard exit tray (on top of the machine) was selected to receive the duplex copies, the print will not enter the duplex unit after the second side has been printed. The junction gate inside the machine directs it upwards to the selected tray.
- Duplex copies are not fed out to the external tray (on the left of the machine).

6.10.2 DUPLEX OPERATION

Up to A4/LT (8 1/2" x 11") LEF

There are three sheets of paper in the paper feed path at the same time. The interleave method is used.

Example: 8 pages. The callout [A] in the illustration shows the order of pages. The callout [B] in the illustration shows the order of sheets of paper (shaded indicates the second side).

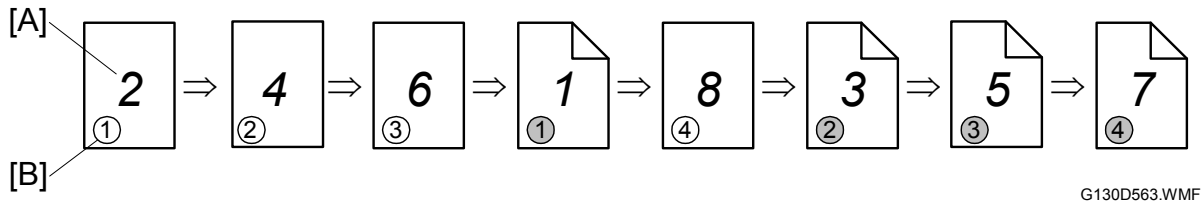

Larger than A4/LT (8 1/2" x 11") LEF

There are two sheets of paper in the paper feed path at the same time. The interleave method is used.

Example: 8 pages. The callout [A] in the illustration shows the order of pages. The callout [B] in the illustration shows the order of sheets of paper (shaded indicates the second side).

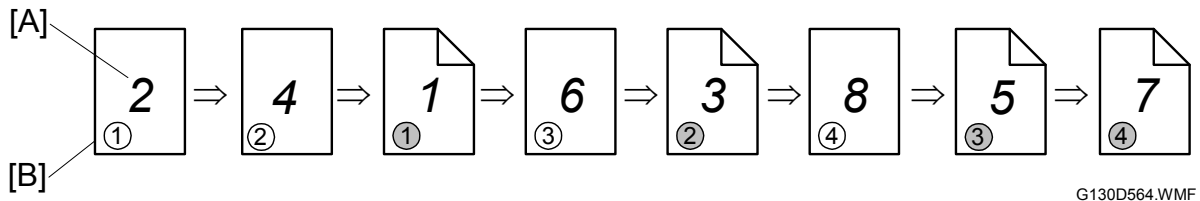

6.10.3 DUPLEX INVERTER UNIT

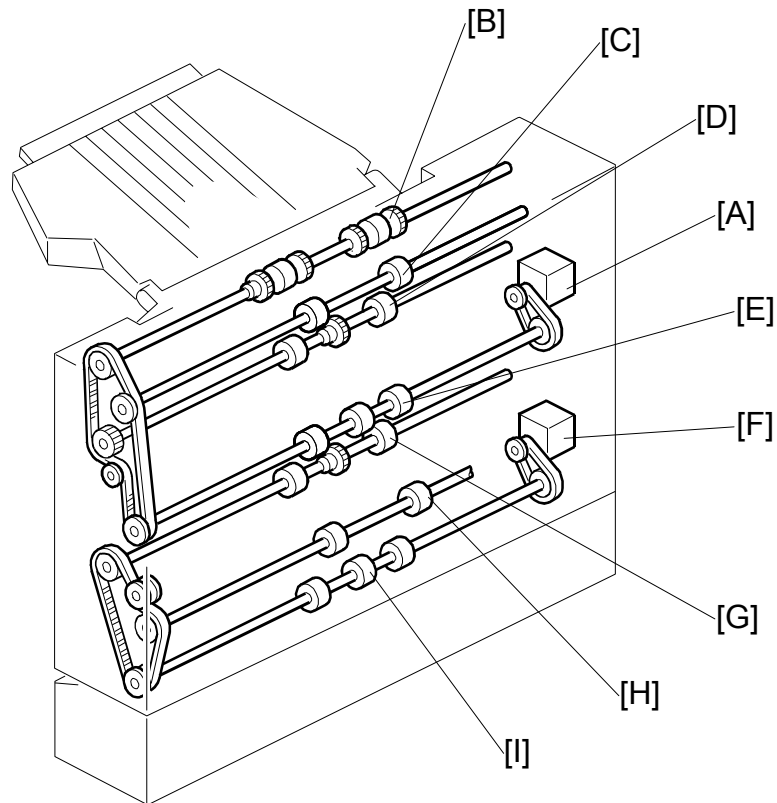

G130D565.WMF

The duplex inverter motor 1 [A] drives the following:

- Paper exit roller 1 [B]
- Paper transport roller [C]
- Paper exit roller 2 [D]
- Upper inverter roller [E].

The duplex inverter motor 2 [F] drives the following:

- Exit roller 3 [G]
- Paper exit roller 4 [H]
- Lower inverter roller [I].

6.10.4 FEED TO EXTERNAL EXIT TRAY (NON-DUPLEX MODE)

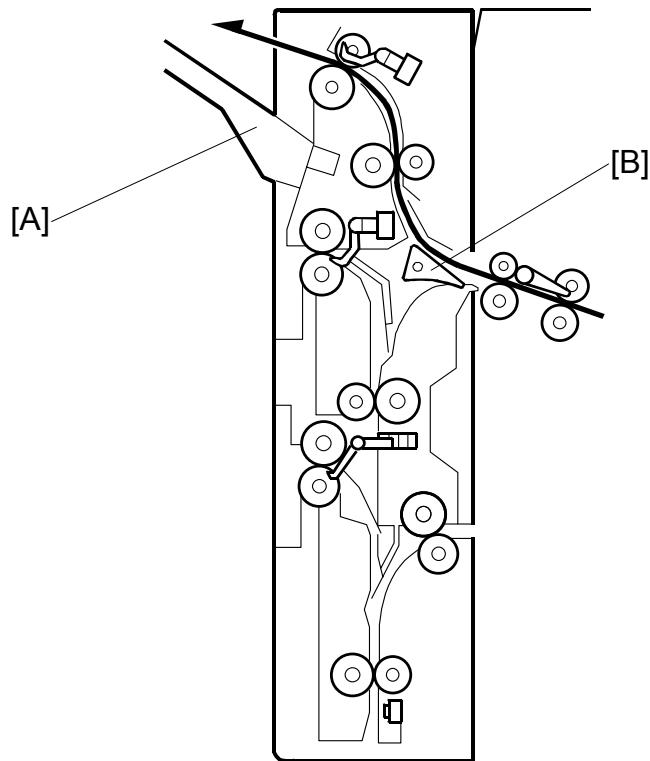

G130D566.WMF

This shows how the machine feeds paper through the duplex unit to the external tray [A], when duplex mode is not selected.

NOTE: The paper cannot be fed out to the external tray if duplex printing is selected.

The junction gate [B] directs the paper from the fusing unit out to the external tray at one of the following times:

- If thick paper or OHP mode is selected
- If the external tray is selected as the output tray with the operation panel or the printer driver

6.10.5 FEED TO DUPLEX FEED UNIT

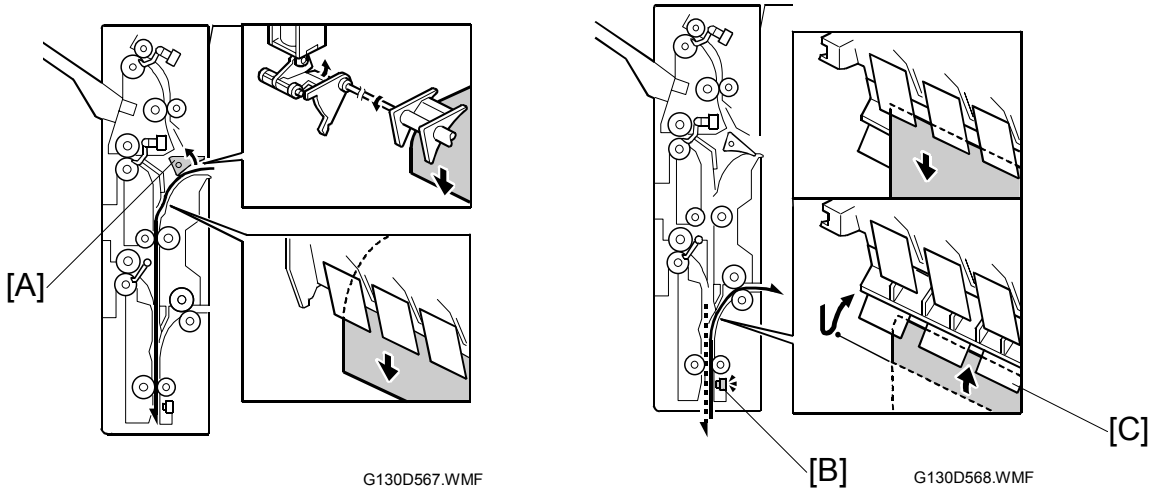

This shows how the machine feeds paper back into the machine after side 1 is printed.

The junction gate [A] diverts the paper from the fusing unit to the lower part of the inverter unit. After the duplex inverter sensor [B] is activated, the machine waits until the trailing edge has passed junction mylar 3 [C]. Then the paper is switched back and junction mylar 3 directs the paper back into the machine for the second side.

The next page shows how the paper is fed out to the finisher after both sides are printed.

Detailed Descriptions

6.10.6 FEED TO TWO-TRAY FINISHER AND BOOKLET FINISHER

With Optional One-Tray Paper Feed Unit

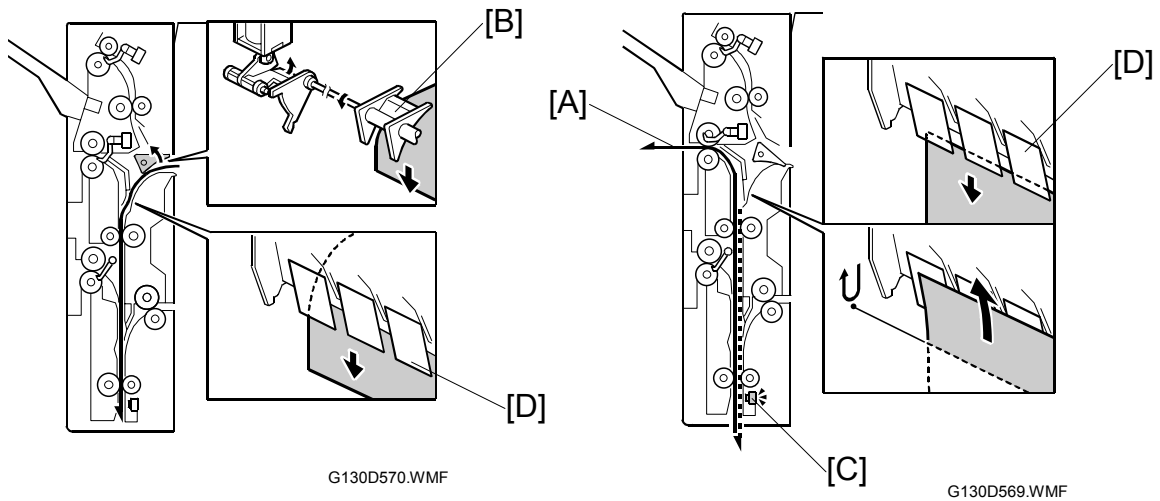

The paper is fed out to the finisher from the upper exit [A].

The junction gate [B] diverts the paper from the fusing unit to the lower part of the inverter unit. After the duplex inverter sensor [C] is activated, the machine waits until the trailing edge has passed junction mylar 1 [D]. Then the paper is switched back and junction mylar 1 directs the paper out to the finisher.

With Optional LCT or Two-Tray Paper Feed Unit

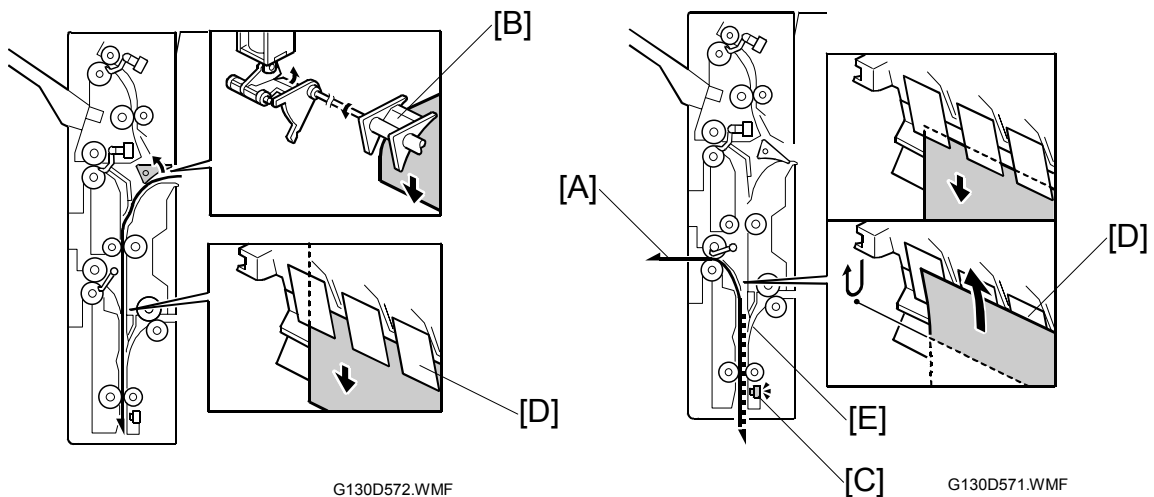

The paper is fed out to the finisher from the lower exit [A].

The junction gate [B] diverts the paper from the fusing unit to the lower part of the inverter unit. After the duplex inverter sensor [C] is activated, the machine waits until the trailing edge has passed junction mylar 2 [D], but before it passes junction mylar 3 [E]. Then the paper is switched back and junction mylar 2 directs the paper out to the finisher.

6.10.7 DUPLEX FEED UNIT

Drive

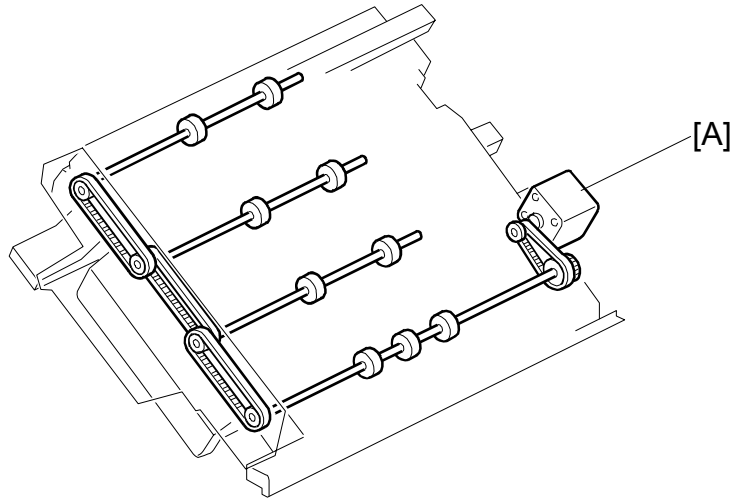

G130D573.WMF

The duplex feed motor [A] drives all paper transport rollers.

Feed-in and feed-out

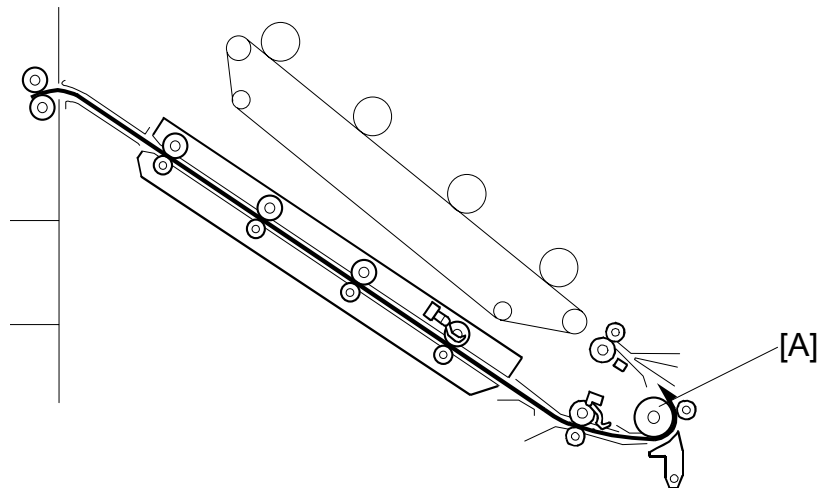

G130D574.WMF

The duplex feed unit feeds the paper from the duplex inverter unit to the relay roller [A].

Detailed
Descriptions

6.11 PRINTER FUNCTIONS

6.11.1 OVERVIEW

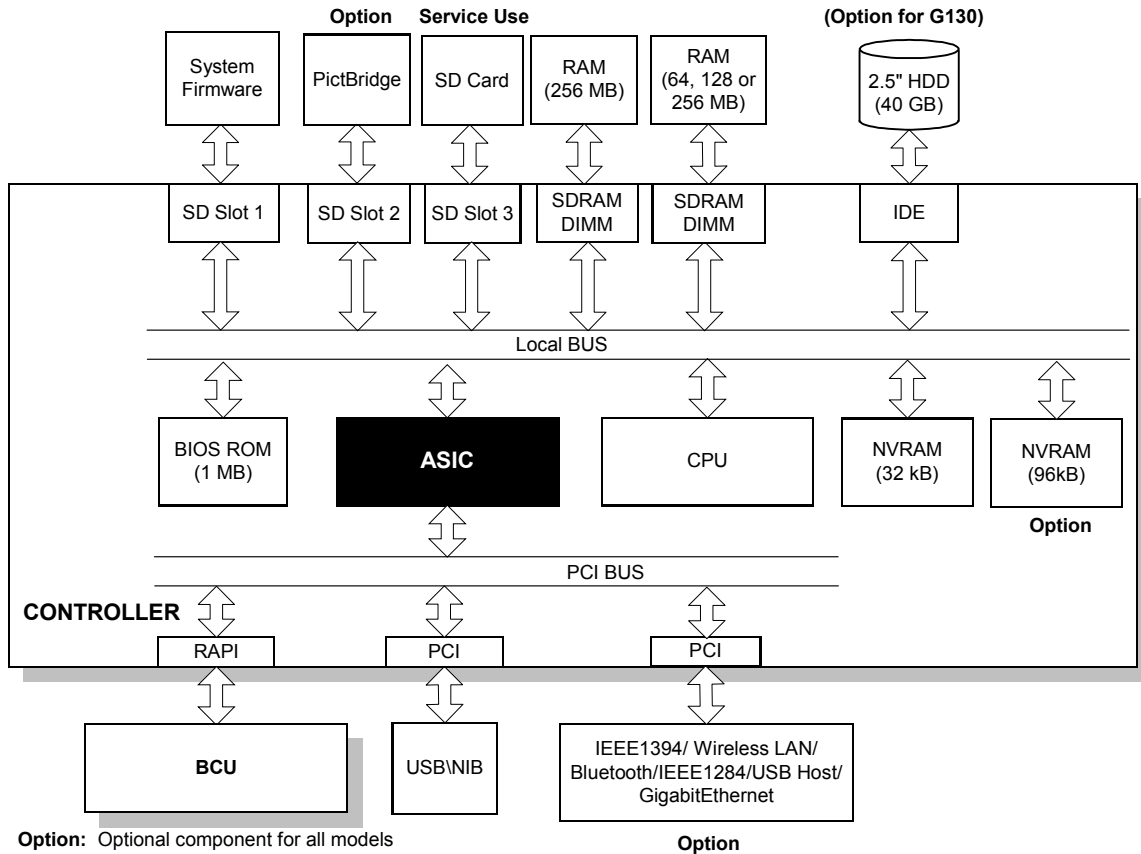

G130D912.WMF

The controller is based on the GW (Grand Work) architecture.

CPU: ICP LV-733 MHz

ASIC:

This is an example of ASICs GW-architecture. It uses a 133 MHz bus to interface with the CPU and memory. ASIC controls the interface, memory, local bus, interruption processing, PCI bus, video data, HDD, network, operation panel, host interface, and image processing.

BIOS ROM: The 1-MB BIOS ROM is for the boot program.

SDRAM DIMM (2 slots):

The controller has 256-MB resident SDRAM. (Either 64, 128 or 256 MB for optional SDRAM)

NVRAM:

The 32-KB NVRAM stores the engine/controller settings and logs.

Interface Option:

You can install one of the six network components (IEEE1284, IEEE1394, Wireless LAN, Bluetooth, Gigabit Ethernet, USB Host I/F).

HDD:

A 40-GB HDD is standard only for the G131. The hard disk is partitioned as shown below. You cannot change the partition sizes.

6.11.2 HARD DISK**Overview**

The capacity of the hard disk is 40 GB. The controller partitions it into several drives and allocates them for different functions. You can initialize the hard disk as necessary (☛ SP5-832). The table lists the contents of the hard disk.

Area	Use	Size (MB)	Volatile/Nonvolatile	Capacity
File System 1	Font download, Form registration	500	Nonvolatile	6,600 files
File System 2	Job spooling	1000	Volatile	5,000 files
File System 3	Temporary printer data	500	Volatile	1,000 files
Temporary image data	Electronic sort	5,000	Volatile	1,000 pages
Local Storage image data	Temporary printer document/ stored document	20,000	Nonvolatile	9,000 pages
Image stamp	Image overlay	1,000	Nonvolatile	100 pages
Job log	Job logs	100	Nonvolatile	
Swap/log area	Swapping, Debugging, Debugging logs	364	Nonvolatile	

Volatile: The data is lost when you turn the main switch off.

Nonvolatile: The data is not lost when you turn the main switch off.

6.11.3 PRINT DATA PROCESSING

RPCS Driver

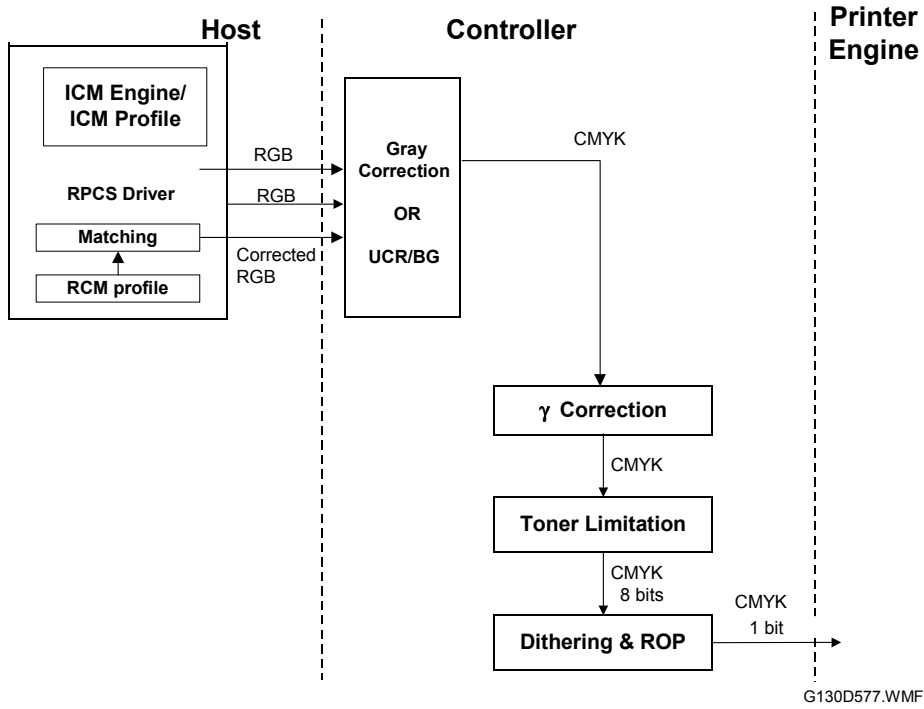

PCL5c/PCLXL Driver

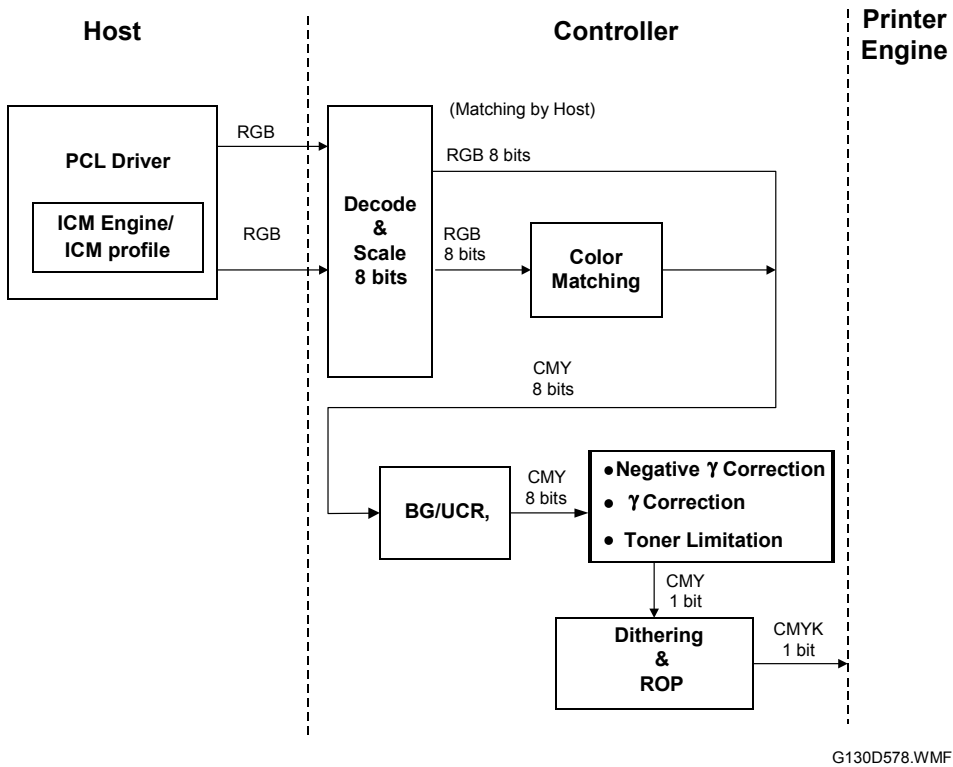

PS3 Driver

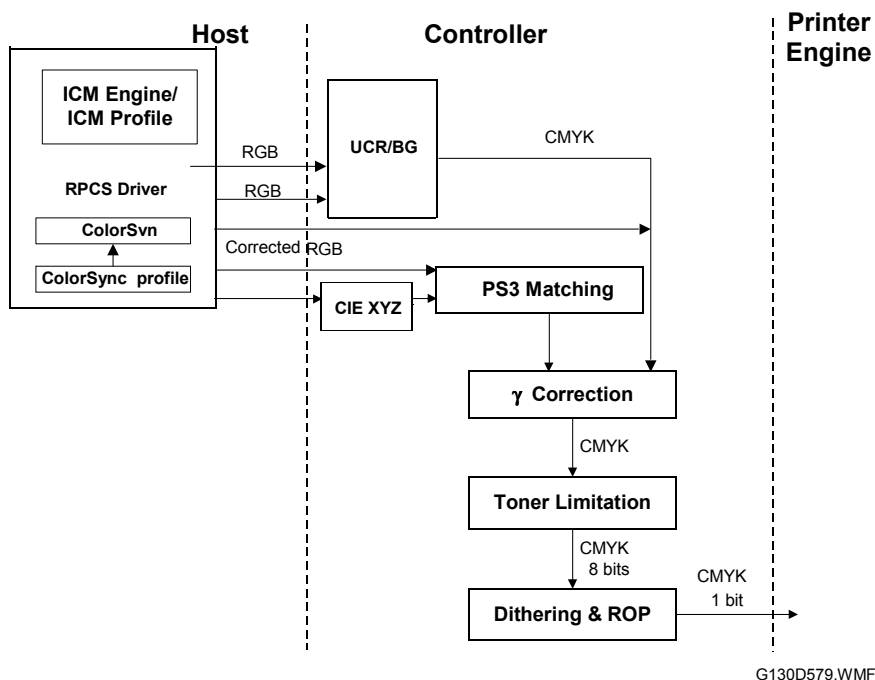

CMS (Color Management System)

CMS optimizes the color print quality using a color profile that is based on the characteristics of the printer. With RPCS, the color profile is applied by the driver. With PS3, PCL5c and PCLXL, the color profile is applied in the matching/CRD module on the controller except when using CMM/ICC/ICM profiles.

CMS is not used when the color profile setting in the printer driver is set to “Off.”

Gray Correction

Gray correction processes gray with the K or CMYK toner depending on the driver settings.

BG/UCR (Black Generation/Under Color Removal)

The RGB data is converted to CMYK data with BG/UCR. During CMYK conversion, some CMY data is replaced with K data by the BG/UCR algorithm.

Gamma Correction

The printer gamma can be adjusted with controller SP mode (Gamma Adj.). For CMYK, there are 15 points between 0 and 100%. The corrected gamma data is stored in NVRAM.

Detailed Descriptions

Toner Limitation

Toner limitation prevents toner from being scattered around text or printed lines.

Maximum values have been prepared independently for text and photo. They can be adjusted with controller SP mode (Toner Limit). If the "Text Priority" is selected with the "4C Graphic Mode" in the UP mode, the maximum values of the photos are the same as the values of the text.

- Default: 190% for text, 260% for photo
- Adjustable range: 100% to 400%

Dither Processing and ROP/RIP

Dither patterns have been prepared for photo and text independently. Dithering converts 8-bit data to 1-bit or 2-bit data. However, these dither patterns create the illusion of 256 gradations for high quality prints. The optimum dither pattern is selected depending on the selected resolution.

RIP: Raster Image Processing

ROP: Raster Operation

6.11.4 CONTROLLER FUNCTIONS

Sample Print

This feature was formerly known as "Proof Print." This function gives users a chance to check the print results before starting a multiple-set print run. Only the first page gets printed.

Hold Print

This feature has the same function as "Sample Print". The difference from "Sample Print" is that a print job can be checked and printed with Web Image Monitor and no page is printed to check the print result. The print job data is deleted after printing.

Locked Print

Using this feature, the print job is stored in the machine but will not be printed until the user inputs an ID at the machine's operation panel. This ID must match the ID that has been input with the printer driver.

Stored Print

This feature has the same function as "Locked Print". The difference from "Locked Print" is that a print job can be checked and printed with Web Image Monitor. The print job data is stored after printing.

- The size of the hard disk partition for these features is 20 GB.
- The partition can hold up to 100 files, including files stored using these features.
- The partition can hold a log containing up to 30 errors, including these features.
- The maximum number of pages is 9,000 (1,000/file), including jobs using these features.
- Stored data is automatically deleted after it is printed (except stored print).
- Stored data can be manually deleted at the operation panel or WIM.

6.11.5 JOB SPOOLING

Print data can be spooled (stored) in the machine's HDD, and the machine starts to print when data transfer is complete. Since the machine stores all data first before printing, the host computer is freed up more quickly.

NOTE: 1) The supported print protocols are IPP and LPR.
2) The default setting for this feature is "off". The user must switch it on using UP mode to enable this feature.

- The size of the HDD partition for job spooling is 1 GB.
- The partition can hold up to 150 jobs.

Related SP Modes

Job spooling can be turned on and off using the SP mode (SP5-828-069) for each protocol.

The machine does not spool jobs when job spooling is switched off with the SP mode, even when the customer switches it on with the user mode.

Paper Source Selection

Tray Priority (Auto Tray Select)

The “Tray Priority” setting determines the start of the tray search when the user selects “Auto Tray Select” with the driver. The machine searches paper trays for the specified paper size and type.

When no tray contains paper that matches the paper size and type specified by the driver, the controller stops printing until the user loads the correct paper.

The “Tray Priority” setting can be specified in the UP mode.

NOTE: The by-pass feed table is not part of the tray search.

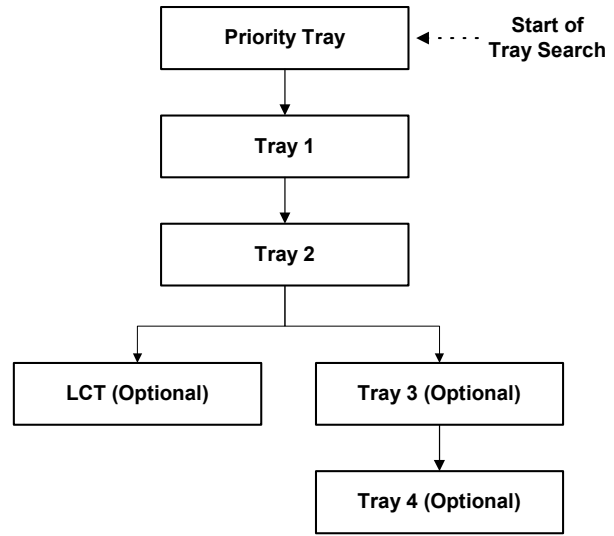

G130D580.WMF

Tray Locking

If “Tray Locking” is enabled for a tray, the controller skips the “locked” tray in the tray search process.

The “Tray Locking” setting can be specified in the UP mode.

NOTE: The by-pass feed table cannot be unlocked (Tray Locking is always enabled).

Manual Tray Select

If the selected tray does not have the paper size and type specified by the driver, the controller stops printing until the user loads the correct paper.

Detailed Descriptions

Auto Continue

Overview

When this function is enabled, the machine waits for a specified period (0, 1, 5, 10, 15 minutes) for the correct paper size and type to be set in the tray. If the timer runs out, the machine starts printing, even if there is no paper tray which matches the paper size and paper type specified by the driver.

The machine searches for a paper tray in the following way:

- The interval can be set with the UP mode.

NOTE: The default setting for this feature is “Off.”

Auto Tray Select

When there is no paper tray that matches the paper size and type specified by the driver, the machine searches for any tray that has paper, and prints from the first tray it finds. The start of the tray search is the tray selected as the priority tray.

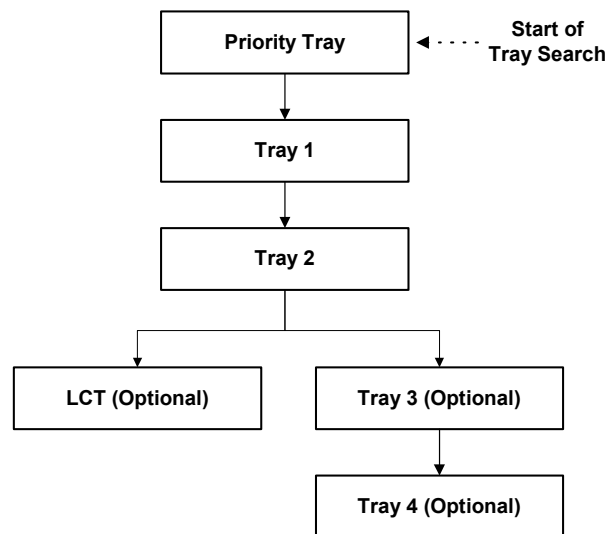

G130D581.WMF

Manual Tray Select

The machine prints from the selected tray even if the paper size and type do not match the setting specified from the driver.

If “Auto Continue” is disabled, the machine waits until the user loads the correct paper in the tray.

Paper Output Tray

You can select default output tray as follows: Menu > System > Output Tray. If a print job does not specify an output tray or if the driver specifies the default tray, the output tray selected with this UP mode will be used. If the output tray is selected with the printer driver, this setting has priority over the default setting.

Output Tray Selected

- If the machine cannot print to the selected output tray, it prints to the default paper output tray.
- If paper overflow is detected at the selected output tray, the controller suspend printing.

Stapling

The optional two-tray finisher and booklet finisher can staple papers. Both finishers support the following stapling positions:

- [A]: One staple (vertical) is at the rear right corner.
- [B]: Two staples (vertical) are at the right middle edge.
- [C]: One staple (vertical) is at the front right corner.

The two-tray finisher supports the following stapling position (the booklet finisher does not):

- [D]: One staple (slant) is at the front right corner.

The booklet finisher supports the following stapling position (the two-tray finisher does not):

- [E]: Two staples (vertical) are at the center.

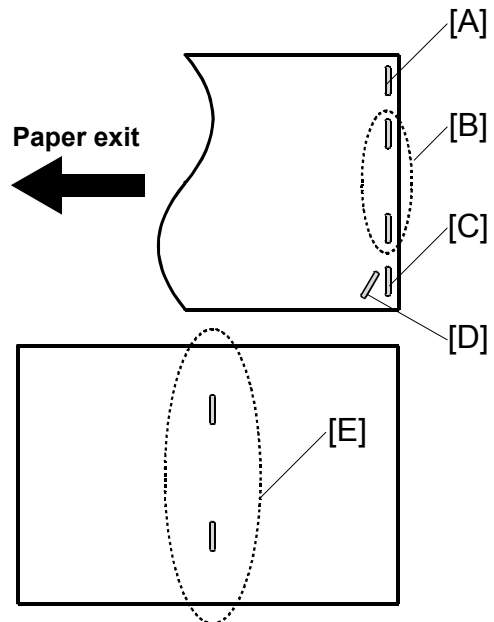

G130D582.WMF

Detailed Descriptions

The table lists the number of papers that the finishers can staple.

	Position	Paper size	
		A4, B5, LT (8 1/2" x 11")	A3, Ledger, Legal
Two-tray finisher	[A][B][C][D]	50 sheets	30 sheets
Booklet finisher	[A][B][C]	50 sheets	25 sheets
	[E]	—	10 sheets

NOTE: For more paper sizes, see the specifications.

Punching

To enable a finisher to punch out holes, you must install the optional punch unit to it. Each punch unit needs the dedicated punch unit. Note that these punch units are not interchangeable with each other. To make two holes on a sheet of paper, you must install the two-hole type; to make three, the three-hole type; and to make four, the four-hole type. The table shows which type you can install to your finisher.

Finisher model	Two holes	Three holes	Four holes
North America	✘	✘	N/A
Europe (excluding North Europe)	✘	N/A	✘
North Europe	N/A	N/A	✘

✘: Available
 N/A: Not available

6.12 -PICTBRIDGE

Pictbridge lets you connect a digital still camera directly to a printer without a PC. This lets you print directly on the spot.

You need the PictBridge module (SD card) and Enhancement USB host board (USB Host I/F) to use this function.

PictBridge products can do the following.

- 1) Connect digital still cameras to the printer:
 - You can connect the camera to the printer with a USB cable. You do not have to install any software to get a direct connection regardless of the camera maker.
- 2) Single image printing:
 - The button controls on the camera let you immediately print an image shown on the LCD display of the camera.
- 3) Error message:
 - An error message shows on the LCD if an error occurs during printing.

SPECIFICATIONS

1. GENERAL SPECIFICATIONS

Configuration: Desktop
 Print Process: Dry electrostatic transfer system
 Printer Languages: RPCS (Refined Printing Command Stream),
 PCL5c,
 PCLXL,
 Adobe PostScript 3
 Resolution: True 1200 x 1200 dpi, 1200 x 600 dpi,
 600 x 600 dpi
 Gradation 1 bit/pixel
 Printing speed: G130

	Resolution	Plain paper	Thick/OHP
Monochrome	600 x 600 dpi	32 ppm	14 ppm
	1200 x 600 dpi	32 ppm	14 ppm
	1200 x 1200 dpi	17 ppm	14 ppm
Color	600 x 600 dpi	28 ppm	14 ppm
	1200 x 600 dpi	28 ppm	14 ppm
	1200 x 1200 dpi	17 ppm	14 ppm

G131

	Resolution	Plain paper	Thick/OHP
Monochrome	600 x 600 dpi	35 ppm	14 ppm
	1200 x 600 dpi	35 ppm	14 ppm
	1200 x 1200 dpi	17 ppm	14 ppm
Color	600 x 600 dpi	35 ppm	14 ppm
	1200 x 600 dpi	35 ppm	14 ppm
	1200 x 1200 dpi	17 ppm	14 ppm

Resident Fonts: PCL5c:
 35 Intelli fonts
 10 TrueType fonts
 1 bitmap font
 International Font (Cyrillic, Greek, Hebrew, Arabic)
 13 fonts
 Adobe PostScript 3:
 136 fonts (24 Type 2 fonts, 112 Type 14 fonts)



Host Interfaces: USB 2.0 Standard
 Ethernet (100 Base-TX/10 Base-T) Standard
 Bi-directional IEEE1284 parallel x 1 Optional
 IEEE 1394 Optional
 IEEE 802.11b (Wireless LAN) Optional
 Bluetooth (Wireless) Optional
 Gigabit Ethernet Optional
 USB Host I/F Optional

Network Protocols: TCP/IP, IPX/SPX, NetBEUI, AppleTalk

First Print Speed: 8 seconds or less (from tray 1)

Warm-up Time Less than 99 seconds (at 23°C/50%)

Print Paper Capacity: Standard tray: 500 sheets x 2
 (80 g/m², 20 lb) By-pass tray: 100 sheets
 Optional paper feed tray: 500 sheets x 1, 500 sheets x 2,
 Optional LCT: 2000 sheets

Print Paper Size: (Refer to "Supported Paper Sizes".)

	Minimum	Maximum
Tray 1	A4/8 1/2" x 11" (LEF)	
Tray 2	A5 (LEF)/8 1/2" x 11"	A3/11" x 17"
By-pass	90 x 148 mm	305 x 458 mm/12" x 18"
Optional Tray	A5 (LEF)/8 1/2" x 11"	A3/11" x 17"
LCT	A4/8 1/2" x 11" (LEF)	

Printing Paper Weight: Standard tray: 60 to 105 g/m² (16 to 28 lb.)
 Optional paper tray: 60 to 105 g/m² (16 to 28 lb.)
 By-pass tray: 60 to 163 g/m² (16 to 43 lb.)

Output Paper Capacity: Standard exit tray: 500 sheets (face down)
 External exit tray: 100 sheets (face up)

Memory: Standard 256 MB, up to 512 MB with optional DIMM

Power Source: NA: 120 V, 60 Hz: More than 12 A (G131)/
 11 A (G130)
 EU/ASIA: 220 V – 240 V, 50/60 Hz: More than
 7.0 A (G131)/ 6.0 A (G130)

Power Consumption:

	120V	230V
Maximum	G130: 1,320 W or less G131: 1,400 W or less	G130: 1,440 W or less G131: 1,550 W or less
Energy Saver	17 W or less	18 W or less

Noise Emission:
(Sound Power Level)

	Mainframe Only	Full System
Printing	68 dB or less	72 dB or less
Stand-by	44 dB or less	
Low power mode	40 dB or less	

NOTE: The above measurements were made in accordance with Ricoh standard methodology.

Dimensions (W x D x H) G130: 575 x 678 x 745 mm (22.6" x 26.7" x 29.3")
G131: 670 x 678 x 745 mm (26.5" x 26.7" x 29.3")

Weight G130: Less than 83.3 kg (183.3 lb.)
G131: Less than 92.5 Kg (203.5 lb)

2. SUPPORTED PAPER SIZES

2.1 PAPER FEED

Paper	Size (W x L)	North America			Europe/Asia			By-pass Tray
		Tray 1	Tray 2/3/4	LCT	Tray 1	Tray 2/3/4	LCT	
A3 W	12" x 18"	N	N	N	N	N	N	Y [#]
A3 SEF	297 x 420 mm	N	Y	N	N	Y	N	Y [#]
A4 SEF	210 x 297 mm	N	Y [#] /Y [*]	N	N	Y	N	Y [#]
A4 LEF	297 x 210 mm	Y [*]	Y	Y [*]	Y	Y	Y	Y [#]
A5 SEF	148 x 210 mm	N	N	N	N	N	N	Y [#]
A5 LEF	210 x 148 mm	N	Y	N	N	Y	N	Y [#]
A6 SEF	105 x 148 mm	N	N	N	N	N	N	Y [#]
B4 SEF	257 x 364 mm	N	Y [#] /Y [*]	N	N	Y	N	Y [#]
B5 SEF	182 x 257 mm	N	Y [#] /Y [*]	N	N	Y [#] /Y [*]	N	Y [#]
B5 LEF	257 x 182 mm	N	Y	N	N	Y	N	Y [#]
B6 SEF	128 x 182 mm	N	N	N	N	N	N	Y [#]
Ledger	11" x 17"	N	Y	N	N	Y	N	Y [#]
Letter SEF	8.5" x 11"	N	Y	N	N	Y [#] /Y [*]	N	Y [#]
Letter LEF	11" x 8.5"	Y	Y	Y	Y [*]	Y	Y [*]	Y [#]
Legal SEF	8.5" x 14"	N	Y	N	N	Y [#] /Y [*]	N	Y [#]
Half Letter SEF	5.5" x 8.5"	N	N	N	N	N	N	Y [#]
Executive SEF	7.25" x 10.5"	N	Y [#]	N	N	Y [#]	N	Y [#]
Executive LEF	10.5" x 7.25"	N	N	N	N	N	N	Y [#]
F SEF	8" x 13"	N	Y [#]	N	N	Y [#]	N	Y [#]
Foolscap SEF	8.5" x 13"	N	Y [#]	N	N	Y [#]	N	Y [#]
Folio SEF	8.25" x 13"	N	Y [#]	N	N	Y [#]	N	Y [#]
8K	267 x 390 mm	N	Y [#]	N	N	Y [#]	N	Y [#]
16K SEF	195 x 267 mm	N	Y [#]	N	N	Y [#]	N	Y [#]
16K LEF	267 x 195 mm	N	Y [#]	N	N	Y [#]	N	Y [#]
Custom	Minimum: 90 x 148 mm Maximum: 305 x 458 mm	N	N	N	N	N	N	Y [#]
Com10 Env.	4.125" x 9.5"	N	N	N	N	N	N	Y [#]
Monarch Env.	3.875" x 7.5"	N	N	N	N	N	N	Y [#]
C6 Env.	114 x 162 mm	N	N	N	N	N	N	Y [#]
C5 Env.	162 x 229 mm	N	N	N	N	N	N	Y [#]
DL Env.	110 x 220 mm	N	N	N	N	N	N	Y [#]

Remarks:

Y	Supported: the sensor detects the paper size.
Y [#]	Supported: the user specifies the paper size.
Y [*]	Supported: depends on a technician adjustment
N	Not supported

2.2 PAPER EXIT

Paper	Size (W x L)	Internal Tray (Face Down)	External Tray (Face Up)	Finisher	Duplex
A3 W	12" x 18"	N	Y	N	N
A3 SEF	297 x 420 mm	Y	Y	Y	Y
A4 SEF	210 x 297 mm	Y	Y	Y	Y
A4 LEF	297 x 210 mm	Y	Y	Y	Y
A5 SEF	148 x 210 mm	Y	Y	N	N
A5 LEF	210 x 148 mm	Y	Y	Y	Y
A6 SEF	105 x 148 mm	Y	Y	N	N
B4 SEF	257 x 364 mm	Y	Y	Y	Y
B5 SEF	182 x 257 mm	Y	Y	Y	Y
B5 LEF	257 x 182 mm	Y	Y	Y	Y
B6 SEF	128 x 182 mm	Y	Y	N	N
Ledger	11" x 17"	Y	Y	Y	Y
Letter SEF	8.5" x 11"	Y	Y	Y	Y
Letter LEF	11" x 8.5"	Y	Y	Y	Y
Legal SEF	8.5" x 14"	Y	Y	Y	Y
Half Letter SEF	5.5" x 8.5"	Y	Y	N	N
Executive SEF	7.25" x 10.5"	Y	Y	Y	Y
Executive LEF	10.5" x 7.25"	Y	Y	N	N
F SEF	8" x 13"	Y	Y	Y	Y
Foolscap SEF	8.5" x 13"	Y	Y	Y	Y
Folio SEF	8.25" x 13"	Y	Y	Y	Y
8K	267 x 390 mm	Y	Y	Y	Y
16K SEF	195 x 267 mm	Y	Y	Y	Y
16K LEF	267 x 195 mm	Y	Y	Y	Y
Custom	Minimum: 90 x 148 mm Maximum: 305 x 458 mm	Y	Y	N	N
Com10 Env.	4.125" x 9.5"	N	Y	N	N
Monarch Env.	3.875" x 7.5"	N	Y	N	N
C6 Env.	114 x 162 mm	N	Y	N	N
C5 Env.	162 x 229 mm	N	Y	N	N
DL Env.	110 x 220 mm	N	Y	N	N

Remarks:

Y	Supported
N	Not supported

3. SOFTWARE ACCESSORIES

The printer drivers and utility software are provided on one CD-ROM. An auto-run installer allows you to select which components to install.

3.1 PRINTER DRIVERS

Printer Language	Windows 95/98/ME	Windows NT4.0	Windows 2000	Windows XP/2003	Macintosh OS 8/9	Macintosh OS X
PCL 5c	Yes	Yes	Yes	Yes	No	No
PS3	Yes	Yes	Yes	Yes	Yes	Yes
RPCS	Yes	Yes	Yes	Yes	No	No
PCLXL	Yes	Yes	Yes	Yes	No	No

- NOTE:**
- 1) The printer drivers for Windows NT 4.0 are only for the Intel x86 platform. There is no Windows NT 4.0 printer driver for the PowerPC, Alpha, or MIPS platforms.
 - 2) The PS3 drivers are all genuine AdobePS drivers, except for Windows 2000 and XP/2003, which uses Microsoft PS. A PPD file for each operating system is provided with the driver.
 - 3) The PS3 driver for Macintosh supports Mac OS 8.6 or later versions.

3.2 UTILITY SOFTWARE

Software	Description
Agfa Font Manager 2000 (Win95/98/ME, 2000/XP, NT4)	A font management utility with screen fonts for the printer.
SmartDeviceMonitor for Admin (Win95/98/ME, 2000/XP/2003, NT4)	A printer management utility for network administrators. NIB setup utilities are also available.
SmartDeviceMonitor for Client (Win95/98/ME, 2000/XP/2003, NT4)	<ul style="list-style-type: none"> • A printer management utility for client users. • A utility for peer-to-peer printing over a NetBEUI or TCP/IP network. • A peer to peer print utility over a TCP/IP network. This provides the parallel printing and recovery printing features.
PS Utility for Mac (Mac)	This software provides several convenient functions for printing from Macintosh clients.
IEEE1394 Utility (Win2000/XP/2003)	This utility removes IEEE1394 driver from Windows 2000/XP/2003.
USB support (Win 95/98/Me)	This is a USB device setup utility for Win 95/98/Me.
DeskTopBinder V2 Lite (Win95/98/ME, 2000/XP, NT4)	DeskTopBinder V2 Lite itself can be used as personal document management software and can manage both image data converted from paper documents and application files saved in each client's PC.

4. MACHINE CONFIGURATION

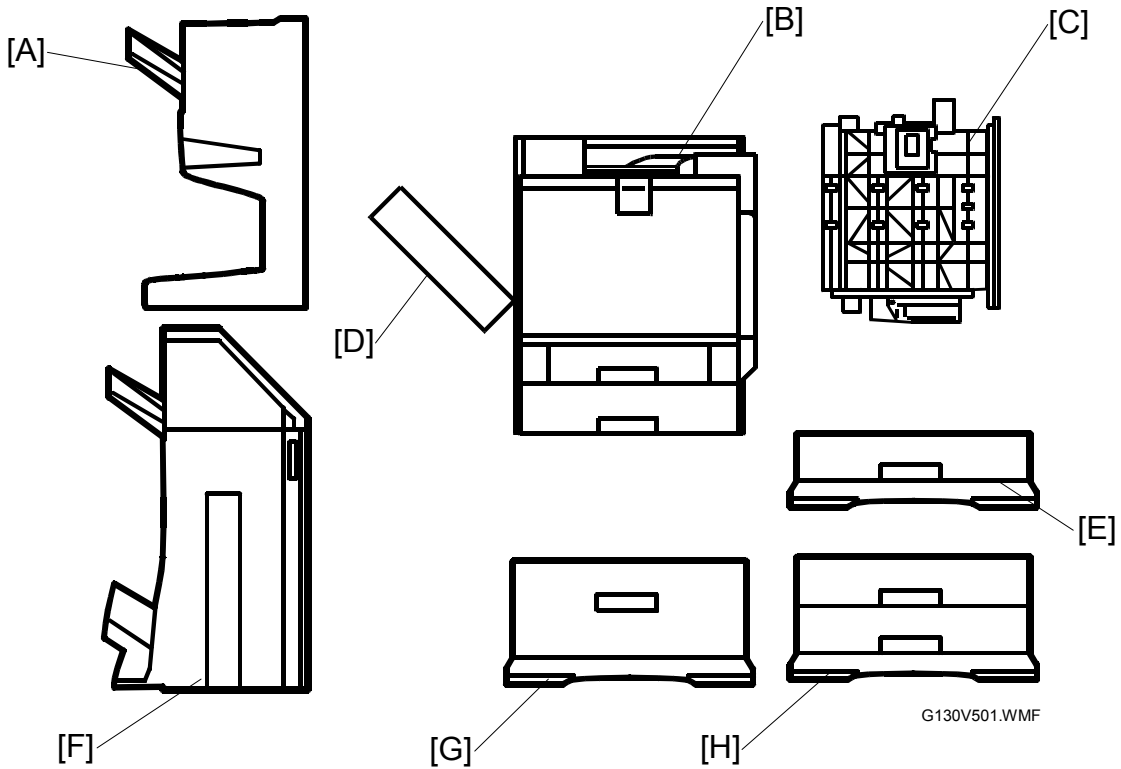

Unit	Machine Code	Diagram	Remarks
Printer*	G130	B	
Two-Tray Finisher	B599	F	<ul style="list-style-type: none"> Requires ① the HDD or 64 MB DIMM memory, ② the duplex unit, and ③ a paper feed unit or the LCT. You cannot install the two-tray finisher and the booklet finisher on the same machine.
Punch Unit (for G565)	B377		Requires the two-tray finisher.
Booklet Finisher	B602	A	<ul style="list-style-type: none"> Requires ① the HDD or 64 MB DIMM memory, ② the duplex unit and ③ a paper feed unit or the LCT. You cannot install the two-tray finisher and the booklet finisher on the same machine.
Punch Unit (for B602)	B647		Requires the booklet finisher.
Paper Feed Unit (500 x 1)*	G567	E	You can install one of these three
Paper Feed Unit (500 x 2)*	G568	H	
LCT*	G569	G	
Duplex Unit (Inverter Unit)*	G382	D	Standard only for G131
Duplex Unit (Feed Unit)*		C	

* The user can install the unit.

Spec.

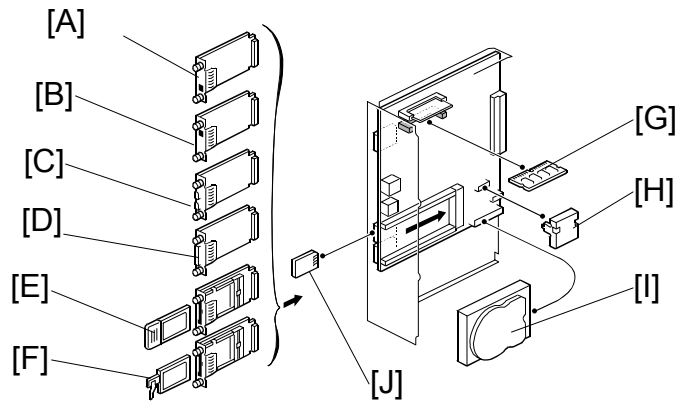

G130V502.WMF

Controller

Unit	M'Code	Diagram	Remarks
Printer Application Program	—		
Gigabit Ethernet	G381	[A]	
USB Host I/F	G819	[B]	
IEEE 1394	B581	[C]	
IEEE 1284	B679	[D]	
IEEE 802.11b	B813	[E]	
Bluetooth	G377	[F]	
64 MB DIMM Memory	G330	[G]	
128 MB DIMM Memory	G331		
256 MB DIMM Memory	G332		
NVRAM Memory	G395	[H]	
HDD	G381	[I]	Standard only for G131
PictBridge	G814	[J]	Requires USB Host I/F
Font SD card	G811		

Others

Maintenance Kit A	G260	Includes CMY PCUs.
Maintenance Kit B	G261-17	Includes CMY development units.
Maintenance Kit C	G259	Includes the fusing unit.
Maintenance Kit D	G261-57	Includes K development unit and dust filter.
Maintenance Kit E	G767	Includes the used toner bottle.
Maintenance Kit F	G260	Includes the K PCU.
Maintenance Kit H	G776	Includes the feed rollers.

5. OPTIONAL EQUIPMENT

5.1 500-SHEET TRAY

Paper Size:	Maximum: A3/11" x 17" (SEF) Minimum: A5 (LEF)/8 1/2" x 11"
Paper Weight:	60 to 105 g/m ² (16 to 28 lb.)
Tray Capacity:	500 sheets (80 g/m ² , 20 lb.)
Paper Feed System:	FRR system
Paper Height Detection:	3 steps (100%, 50%, Near End)
Power Source:	DC 24V, 5V (from the main unit)
Power Consumption:	50 W
Dimensions (W x D x H):	540 x 600 x 172 mm (21.3" x 23.7" x 6.8")
Weight	18 kg (39.7 lb.)

5.2 1000-SHEET TRAY

Paper Size:	Maximum: A3/11" x 17" (SEF) Minimum: A5 (LEF)/8 1/2" x 11"
Paper Weight:	60 to 105 g/m ² (16 to 28 lb.)
Tray Capacity:	500 sheets x 2 (80 g/m ² , 20 lb.)
Paper Feed System:	FRR system
Paper Height Detection:	3 steps (100%, 50%, Near End)
Power Source:	DC 24V, 5V (from the main unit)
Power Consumption:	50 W
Dimensions (W x D x H):	540 x 600 x 270 mm (21.3" x 23.7" x 10.7")
Weight	25 kg (55.2 lb.)

5.3 2000-SHEET LARGE CAPACITY TRAY

Paper Size:	A4/8 1/2" x 11" (LEF)
Paper Weight:	60 to 105 g/m ² (16 to 28 lb.)
Tray Capacity:	2000 sheets (80 g/m ² , 20 lb.)
Paper Feed System:	FRR system
Paper Height Detection:	5 steps (100%, 75%, 50%, 25%, Near End)
Power Source:	DC 24V, 5V (from the main unit)
Power Consumption:	30 W
Dimensions (W x D x H):	540 x 600 x 270 mm (21.3" x 23.7" x 10.7")
Weight	25 kg (55.2 lb.)

5.4 TWO-TRAY FINISHER & PUNCH UNIT

Print Paper Size:	No punch mode: A3/11" x 17" to A5 (LEF)/8 1/2" x 11" Punch mode: 2 holes: A3/11" x 17" to A4/8 1/2" x 11" (SEF) A4/8 1/2" x 11" to A5 (LEF) 3 holes: A3, B4, 11" x 17" (SEF) A4, B5, 8 1/2" x 11" (LEF) 4 holes (Europe): A3, B4, 11" x 17" (SEF) A4, B5, 8 1/2" x 11" (LEF) 4 holes (North Europe): A3, B4, 11" x 17" (SEF) A4, B5, 8 1/2" x 11" (LEF) Staple mode: A3/11" x 17" to B5/8 1/2" x 11"
Paper Weight:	No punch mode: 60 to 105 g/m ² (16 to 28 lb.) Punch mode: 60 to 105 g/m ² (16 to 28 lb.) Staple mode: 64 to 90 g/m ² (17 to 23 lb.) Label/Thick paper/OHP cannot be stapled
Tray Capacity:	Upper tray: 500 sheets: A4, 8 1/2" x 11" , B5, A5 (LEF) 250 sheets: 11" x 17", A3, 8 1/2" x 14", B4 Lower tray (default mode – stapled output only goes to tray 2): 2000 sheets: A4, 8 1/2" x 11" (LEF) 750 sheets: A3, B4, A4, B5, 8 1/2" x 14", 11" x 17", 8 1/2" x 11" (SEF) 500 sheets: A5 (LEF) Lower tray (multi-tray staple mode – stapled output can go to either tray): 1500 sheets: A4, 8 1/2" x 11" (LEF) 750 sheets: A3, B4, A4, B5, 8 1/2" x 14", 11" x 17", 8 1/2" x 11" (SEF) 500 sheets: A5 (LEF)
Staple capacity:	Single size: 50 sheets: A4, 8 1/2" x 11" , B5 30 sheets: A3, B4, 8 1/2" x 14", 11" x 17" Mixed size: 30 sheets: A4 (LEF) & A3, B5 (LEF) & B4, 8 1/2" x 11" (LEF) & 11" x 17"
Staple position:	7 positions 1-staple: 4 positions (Top Left, Top Right, Top Left-Oblique, Top Right-Oblique) 2-staples: 3 positions (Left, Top, Right)

Staple replenishment:	Cartridge (5000 staples)
Power consumption:	60 W
Dimensions (W x D x H):	680 x 620 x 1030 mm (26.8" x 24.4" x 40.6")
Weight	Without punch unit: 53 kg (116.9 lb.) With punch unit: 55 Kg (121.3 lb.)

5.5 BOOKLET FINISHER

Paper Size:	A3, A4, B4, B5, DLT, LG, LT
Booklet Paper Size:	A3, B4, A4 SEF, DLT, LG, LT SEF
Paper Weight:	Stack/Sort mode: 60 to 128 g/m ² (16 to 34 lb.) Staple mode: 64 to 90 g/m ² (17 to 24 lb.) Booklet mode: 64 to 80 g/m ² (17 to 21 lb.)
Tray Capacity:	1,000 sheets: A4, LT, B5 500 sheets: A3, B4, DLT, LG
Booklet Tray Capacity:	2 to 5 sheets/booklet: 20 6 to 10 sheets/booklet: 10
Staple capacity:	A4, B5, LT: 50 sheets A3, B4, DLT, LG: 25 sheets
Booklet capacity:	10 sheets
Staple position:	3 positions (excluding booklet mode) 1-staple: 2 positions (Top right, Top left) 2-staples: 1 positions (Left)
Staple replenishment:	Cartridge (5000 staples)